

# **VERTI-QUAKE 2510-2516 -2521**

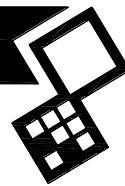

Version: 2203

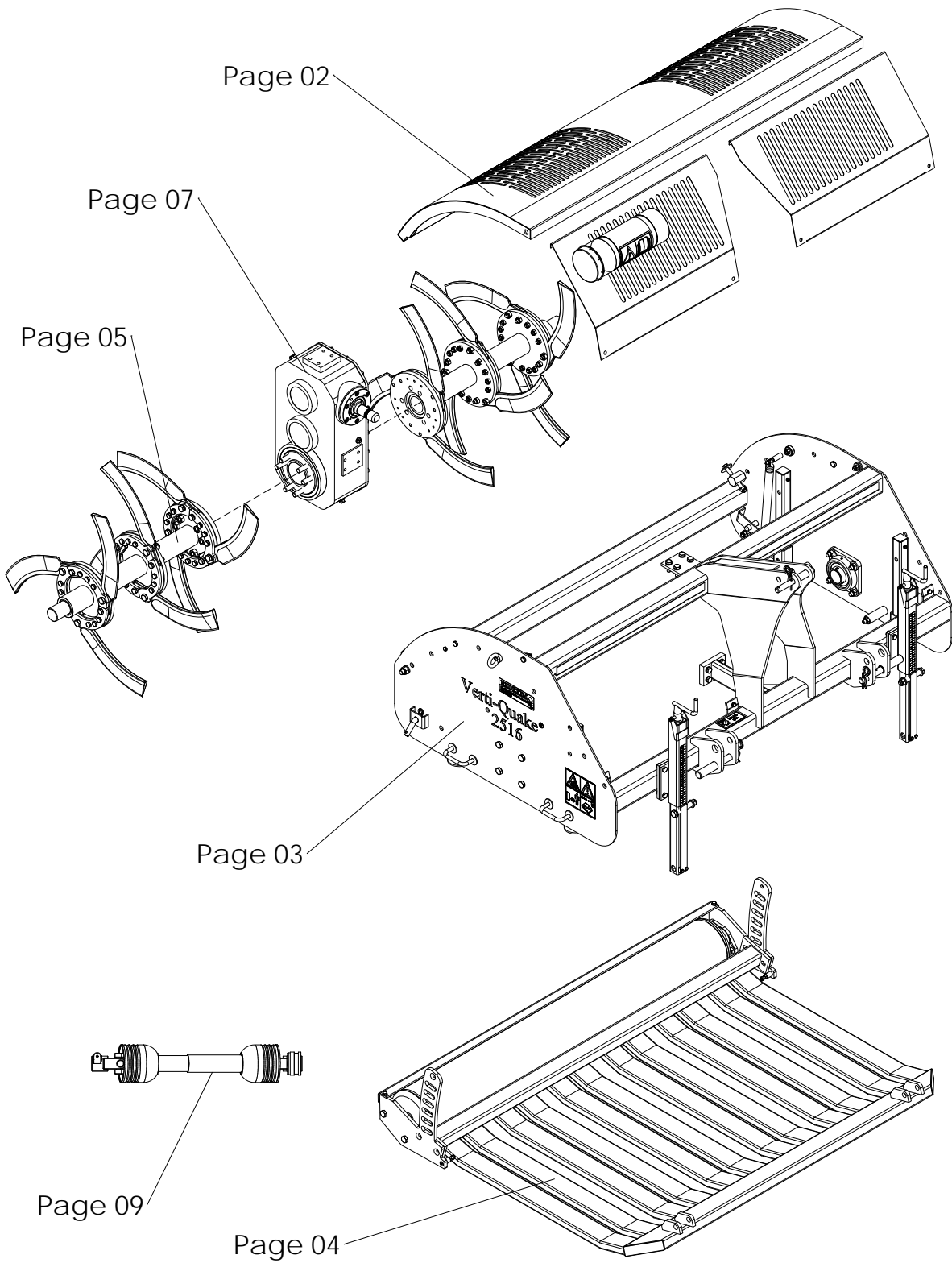



Decals: Page 06  
Optional Coulterknife: Page 08

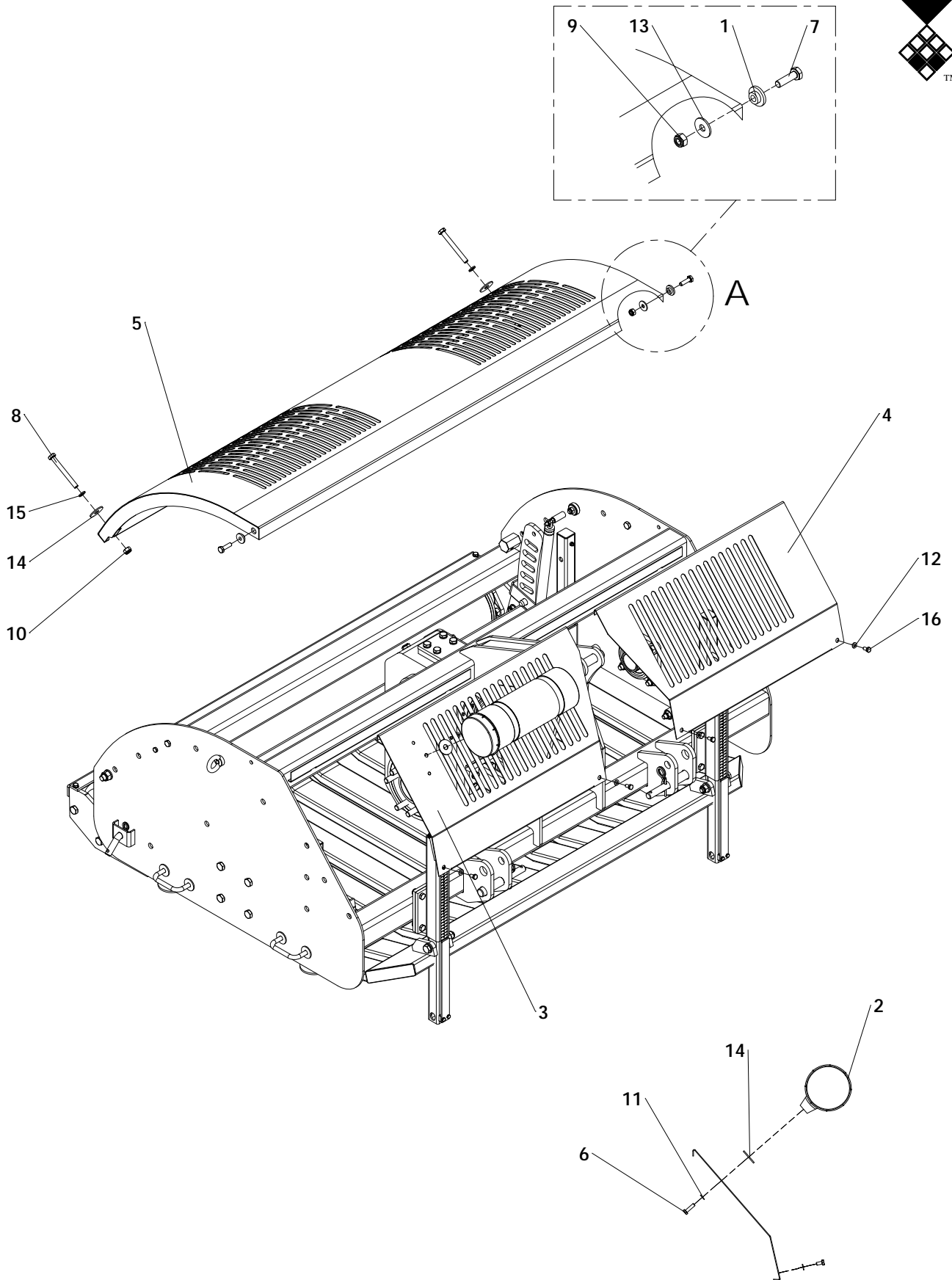

ITEM	PART NUMBER	DESCRIPTION	REMARKS	QUA VQ 2510	QUA VQ 2516	QUA VQ 2521
1	404.100.100	Pivot bush		2	2	2
2	444.803.100	Toolbox Complete		1	1	1
3	468.027.290	Front cover right	Verti-Quake 2510	1	0	0
	468.027.550	Front cover right	Verti-Quake 2516	0	1	0
	468.027.810	Front cover right	Verti-Quake 2521	0	0	1
4	468.027.292	Front cover left	Verti-Quake 2510	1	0	0
	468.027.552	Front cover left	Verti-Quake 2516	0	1	0
	468.027.812	Front cover left	Verti-Quake 2521	0	0	1
5	470.102.064	Cover Verti-Quake 2510	Verti-Quake 2510	1	0	0
	470.162.064	Cover Verti-Quake 2516	Verti-Quake 2516	0	1	0
	470.212.064	Cover Verti-Quake 2521	Verti-Quake 2521	0	0	1
6	804.080.300	Bolt M8 x 30 - ISO 4017		2	2	2
7	804.100.350	Bolt M10 x 35 - ISO 4017		2	2	2
8	804.120.110	Bolt M12 x 110 - ISO 4017		2	2	2
9	830.100.100	Self Lock Nut M10 - ISO 10511		2	2	2
10	830.120.120	Self Lock Nut M12 - ISO 10511		2	2	2
11	864.080.030	Washer M8 - ISO 7089		2	2	2
12	864.080.120	Washer		4	4	4
13	864.100.031	Large washer M10 - DIN 9021		2	2	2
14	864.140.031	Large washer M14 - DIN 9021		4	4	4
15	866.120.020	Spring Washer M12 - DIN 127		2	2	2
16	804.080.160	Bolt M8 x 16 - ISO 4017		4	4	4



**IMPORTANT!**  
Check machine,  
if different: see  
page 03A

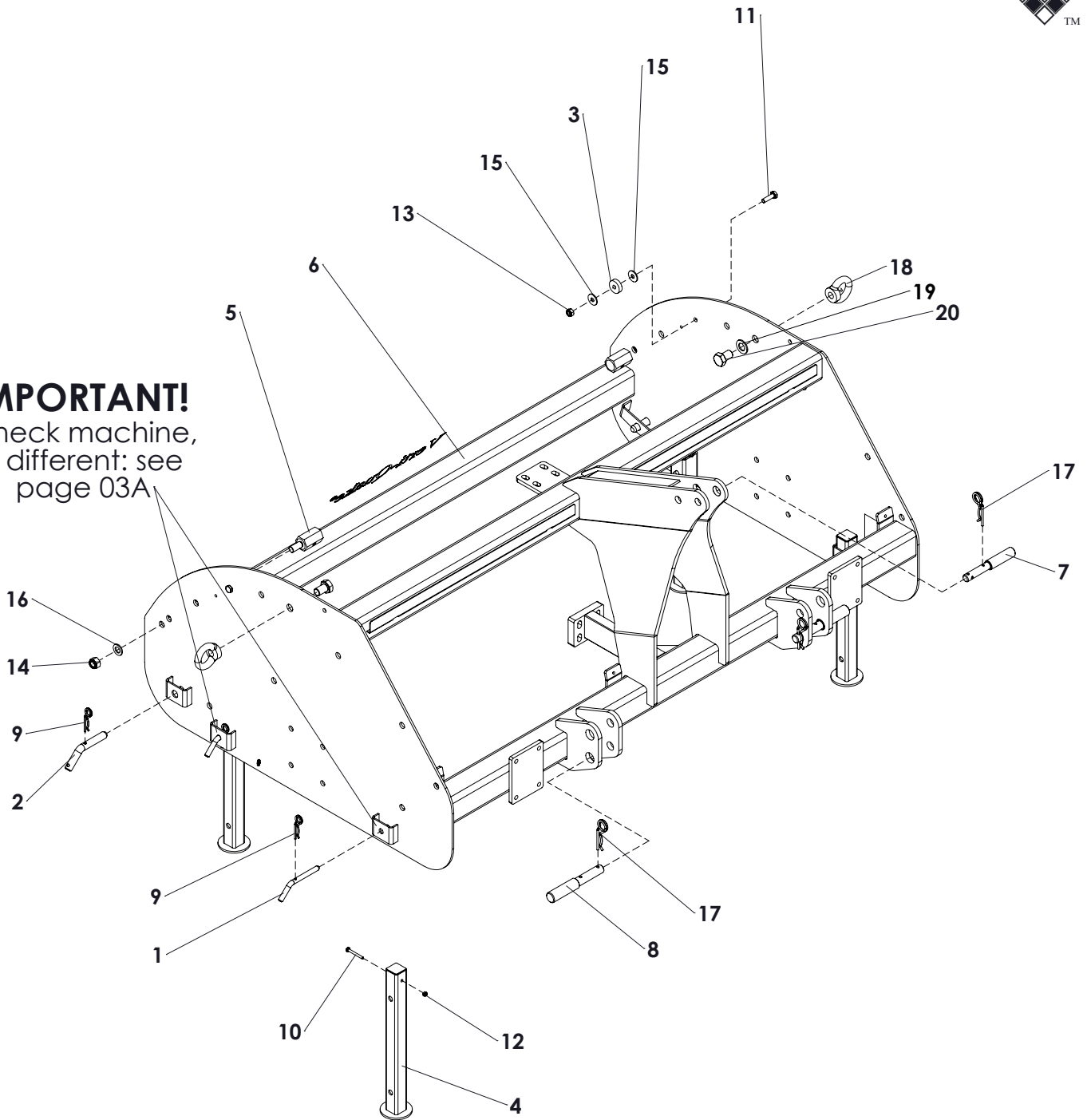

ITEM	PART NUMBER	DESCRIPTION	REMARKS	QUA VQ 2510	QUA VQ 2516	QUA VQ 2521
1	424.121.380	Lock pin Ø12 WL=80		4	4	4
2	424.181.500	Lock pin		2	2	2
3	446.100.100	Rubber ring		2	2	2
4	462.804.320	Stand leg		4	4	4
5	472.380.800	Cover Lock Nut		2	2	2
6	494.193.108	Frame Verti-Quake 2516	Verti-Quake 2516	0	1	0
	494.193.107	Frame Verti-Quake 2510	Verti-Quake 2510	1	0	0
	494.193.109	Frame Verti-Quake 2521	Verti-Quake 2521	0	0	1
7	521.191.600	Top link pin OS		1	1	1
8	521.221.600	3-point pin		0	2	2
	521.211.310	3-Point pin Ø22 WL=103		2	0	0
9	523.030.750	R-Clip Round 3, DIN 11024		6	6	6
10	802.060.500	Bolt M6 x 50 - ISO 4014		4	4	4
11	804.100.350	Bolt M10 x 35 - ISO 4017		2	2	2
12	830.060.060	Self Lock Nut M6 - ISO 10511		4	4	4
13	830.100.100	Self Lock Nut M10 - ISO 10511		2	2	2
14	830.160.160	Self Lock Nut M16 10.9 - ISO 10511		2	2	2
15	864.100.031	Large washer M10 - DIN 9021		4	4	4
16	864.160.030	Washer M16 - ISO 7089		2	2	2
17	523.051.000	R-clip Round 5, DIN 11024		3	3	3
18	842.200.720	Lifting eye nut M20 - DIN 582	From SN H2202531	2	2	2
	822.120.360	Lifting eye nut M12 - DIN 582	Till SN H2202531	2	2	2
19	864.200.030	Washer M20 - ISO 7089	From SN H2202531	2	2	2
20	804.200.300	Bolt M20 x 30 - ISO 4017	From SN H2202531	2	2	2
	804.120.200	Bolt M12 x 20 - ISO 4017	Till SN H2202531	2	2	2



**IMPORTANT!**

Check machine,  
if different: see  
page 03

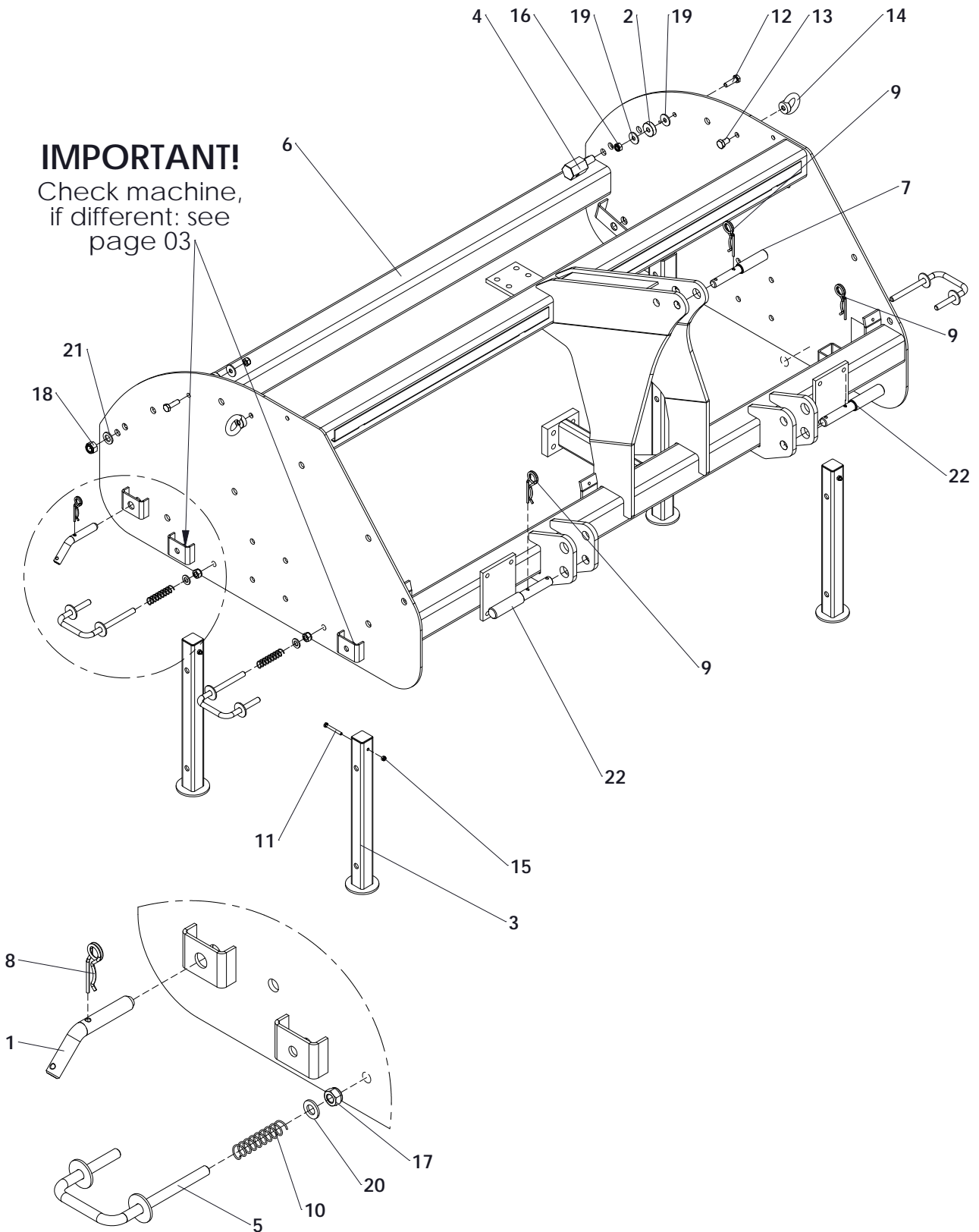



ITEM	PART NUMBER	DESCRIPTION	REMARKS	QUA VO 2510	QUA VO 2516	QUA VO 2521
1	424.181.500	Lock pin		2	2	2
2	446.100.100	Rubber ring		2	2	2
3	462.804.320	Stand leg		4	4	4
4	472.380.800	Cover Lock Nut		2	2	2
5	474.123.700	Weldment hand grip		4	4	4
6	494.193.107	Frame Verti-Quake 2510	Verti-Quake 2510	1	0	0
	494.193.108	Frame Verti-Quake 2516	Verti-Quake 2516	0	1	0
	494.193.109	Frame Verti-Quake 2521	Verti-Quake 2521	0	0	1
7	521.191.600	Top link pin OS		1	1	1
8	523.030.750	R-Clip Round 3, DIN 11024		2	2	2
9	523.051.000	R-clip Round 6, DIN 11024		3	3	3
10	576.180.110	Pressure spring		4	4	4
11	802.060.500	Bolt M6 x 50 - ISO 4014		4	4	4
12	804.100.350	Bolt M10 x 35 - ISO 4017		2	2	2
13	804.120.200	Bolt M12 x 20 - ISO 4017		2	2	2
14	822.120.360	Lifting Eye Nut M12 - DIN 582		2	2	2
15	830.060.060	Self Lock Nut M6 - ISO 10511		4	4	4
16	830.100.100	Self Lock Nut M10 - ISO 10511		2	2	2
17	830.120.120	Self Lock Nut M12 - ISO 10511		4	4	4
18	830.160.160	Self Lock Nut M16 - ISO 10511		2	2	2
19	864.100.031	Large washer M10 - DIN 9021		4	4	4
20	864.120.030	Washer M12 - ISO 7089		4	4	4
21	864.160.030	Washer M16 - ISO 7089		2	2	2
22	521.221.600	3-point pin		2	2	2

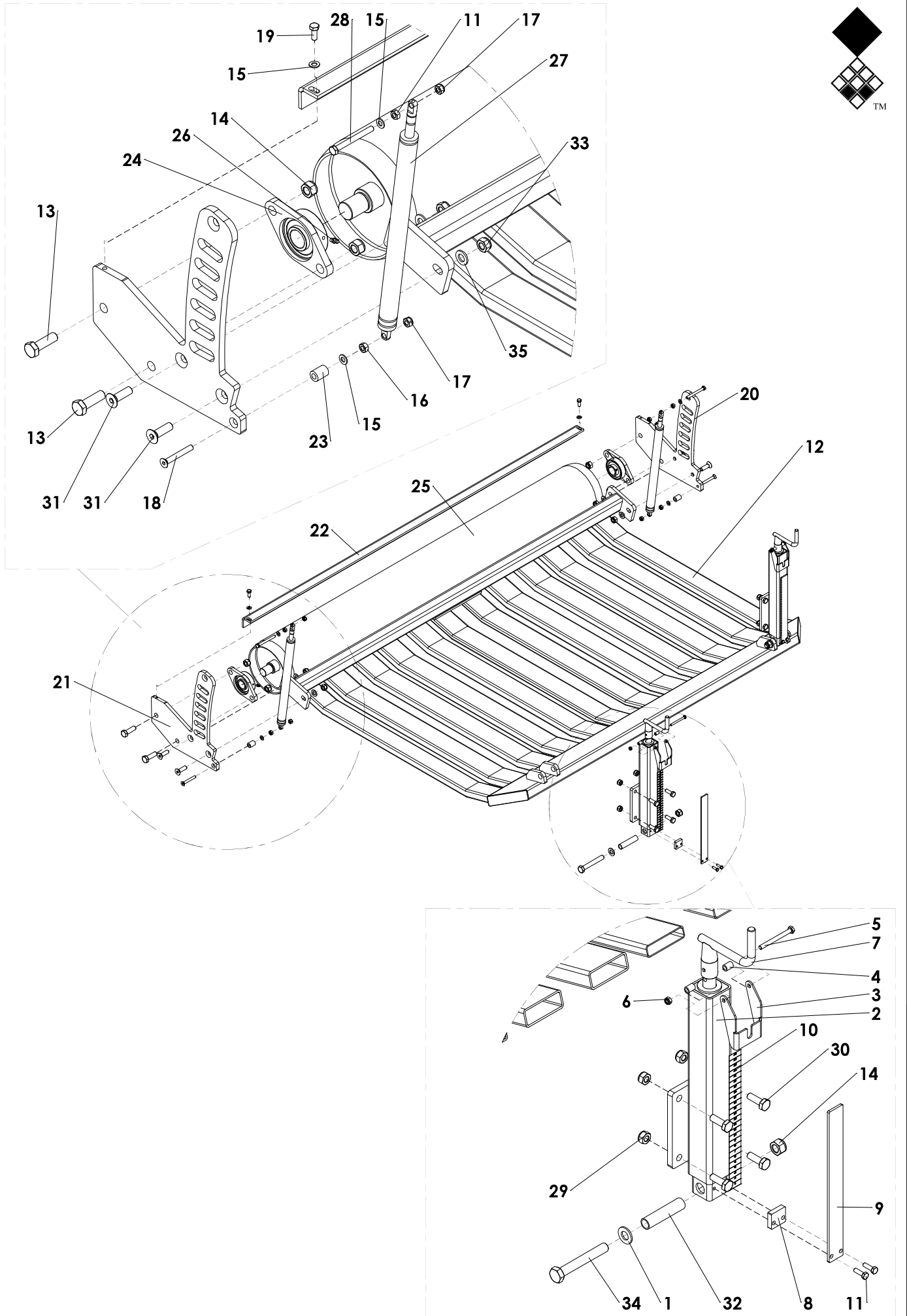

ITEM	PART NUMBER	DESCRIPTION	REMARKS	QUA VQ 2510	QUA VQ 2516	QUA VQ 2521
1	864.140.030	Washer M14 - ISO 7089		2	2	2
2	460.504.080	Weldment jack		2	2	2
3	468.031.180	Lock Plate		2	2	2
4	402.070.140	Distance Bush		4	4	4
5	802.060.650	Bolt M6 x 65 - ISO 4014		2	2	2
6	830.060.060	Self Lock Nut M6 - ISO 10511		2	2	2
7	474.251.162	Lever Jack		2	2	2
8	464.080.304	Distance Block		2	2	2
9	464.042.800	Height Indicator Strip, L= 280		2	2	2
10	900.260.414	Decal Ruler	Cut to 25	2	2	2
11	804.060.200	Bolt M6 x 20 - ISO 4017		4	4	4
12	462.309.102	Skid	Verti-Quake 2510	1	0	0
	462.309.112	Skid	Verti-Quake 2516	0	1	0
	462.309.132	Skid	Verti-Quake 2521	0	0	1
13	804.140.450	Bolt M14 x 45 - ISO 4017		4	4	4
14	830.140.140	Self Lock Nut M14-ISO 10511 Class 10		6	6	6
15	864.080.030	Washer M8 - ISO 7089		6	6	6
16	826.080.080	Nut M8 - DIN 934		4	4	4
17	830.080.080	Self Lock Nut M8 - ISO 10511		4	4	4
18	816.080.600	Bolt M8 x 60 - DIN 7991		2	2	2
19	804.080.200	Bolt M8 x 20 - ISO 4017		2	2	2
20	468.123.900	Support plate left		1	1	1
21	468.123.902	Support plate right		1	1	1
22	468.069.160	Scraper	Verti-Quake 2516	0	1	0
	468.069.110	Scraper	Verti-Quake 2510	1	0	0
	468.069.210	Scraper	Verti-Quake 2521	0	0	1
23	406.090.230	Distance bush		2	2	2
24	742.300.400	Bearing UCFL206		2	2	2
25	488.194.160	Rear roller VQ2516		0	1	0
	488.194.110	Rear roller VQ2510		1	0	0
	488.194.210	Rear roller VQ2521		0	0	1
26	880.060.100	Grease nipple M6 DIN 71412A		2	2	2
27	571.283.802	Gas strut complete		2	2	2
28	802.080.800	Bolt M8 x 80 - ISO 4014		2	2	2
29	830.100.100	Self Lock Nut M10 - ISO 10511		8	8	8
30	804.100.300	Bolt M10 x 30 - ISO 4017		8	8	8
31	816.120.400	Bolt M12 x 40 - DIN 7991		4	4	4
32	406.150.770	Distance bush		2	2	2
33	830.120.120	Self Lock Nut M12 - ISO 10511 Class 10		4	4	4
34	802.141.000	Bolt M14 x 100 - ISO 4014		2	2	2
35	864.120.030	Washer M12 - ISO 7089		4	4	4

**IMPORTANT!**

Check machine,  
if different: see  
page 05A

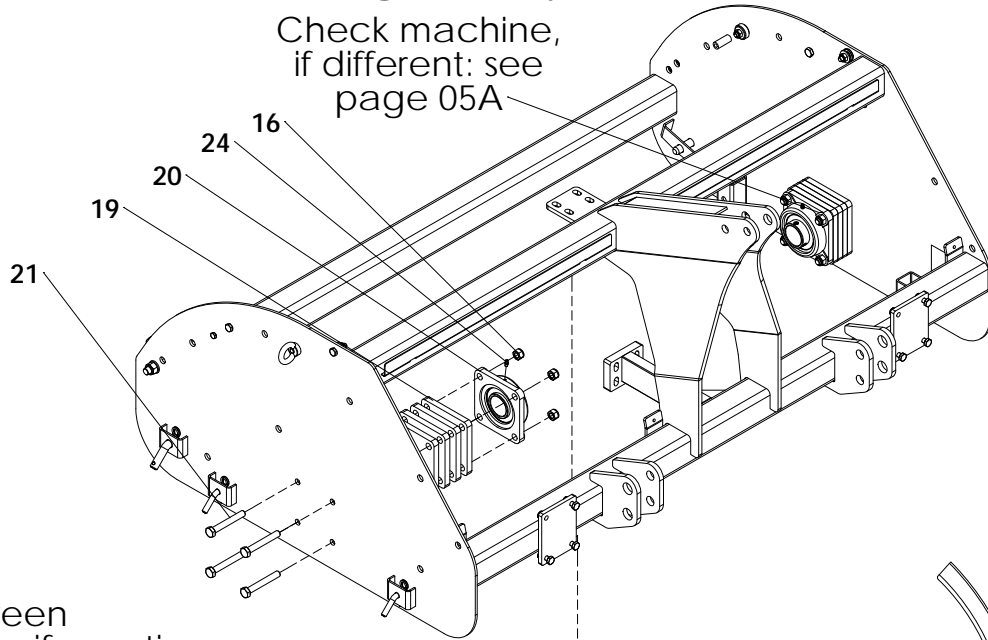
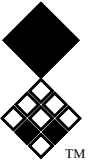

Angle  $\alpha$  between  
left and right knife sections:

- VQ2510 till serial no. A192212:  $46^\circ$
- VQ2510 from serial no. A192212:  $60^\circ$
- VQ2516:  $46^\circ$
- VQ2521 till serial no. A124215:  $46^\circ$
- VQ2521 from serial no. H215022:  $60^\circ$

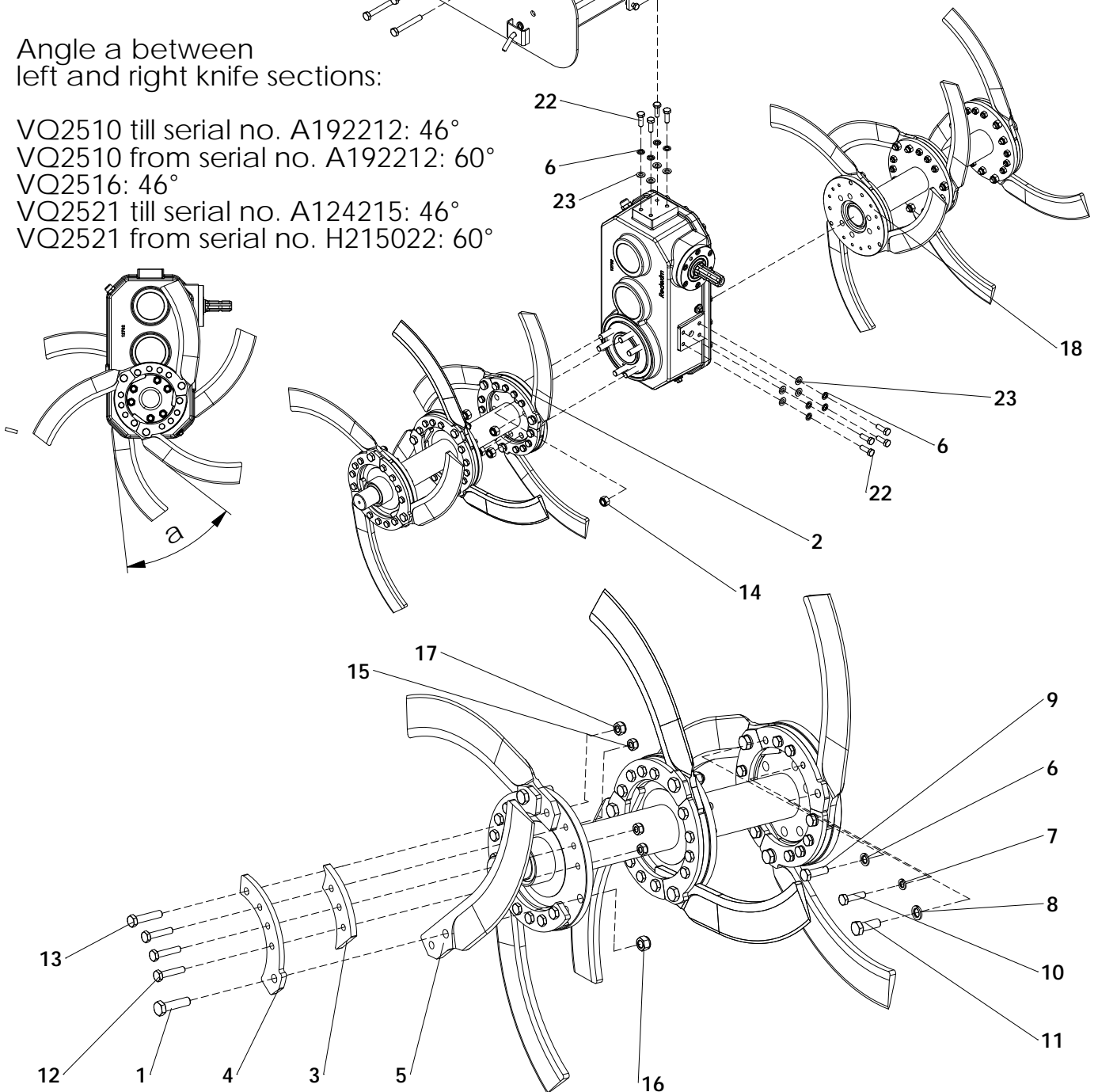

ITEM	PART NUMBER	DESCRIPTION	REMARKS	QUA VQ 2510	QUA VQ 2516	QUA VQ 2521
1	802.140.550	Bolt M14 x 55 - ISO 4014 - 10.9		6	12	18
2	478.245.644	Weldment knife section right	VQ2516 from SN H215016	0	1	0
	478.245.640	Weldment knife section right	VQ2516 till SN H215005	0	1	0
	478.245.382	Weldment knife section right	VQ2510 from SN A192212	1	0	0
	478.245.380	Weldment knife section right	VQ2510 till SN A192212	1	0	0
	478.245.904	Weldment knife section right	VQ2521 from SN H215022	0	0	1
	478.245.900	Weldment knife section right	VQ2521till SN. A124215	0	0	1
3	468.121.190	Fill plate		12	18	24
4	468.101.790	Lock plate		12	18	24
5	I005112R	Blade VQ25		12	18	24
	311.315.421	Blade VQ25 15mm		12	18	24
	311.320.421	Blade VQ25 20mm	Sandmaster	0	18	0
6	866.120.020	Spring Washer M12 - DIN 127		14	14	14
7	866.100.020	Spring Washer M10 - DIN 127		18	18	18
8	866.140.020	Spring Washer M14 - DIN 127		6	6	6
9	804.120.400	Bolt M12 x 40 - ISO 4017		6	6	6
10	804.100.400	Bolt M10 x 40 - ISO 4017		18	18	18
11	804.140.400	Bolt M14 x 40 - ISO 4017		6	6	6
12	802.100.500	Bolt M10 x 50 - ISO 4014		24	36	48
13	802.120.550	Bolt M12 x 55 - ISO 4014 - 10.9		6	12	18
14	830.160.160	Self Lock Nut M16 - ISO 10511		6	12	18
15	830.100.100	Self Lock Nut M10 - ISO 10511		24	36	48
16	830.140.140	Self Lock Nut M14 - ISO 10511		14	20	26
17	830.120.120	Self Lock Nut M12 - ISO 10511		6	12	18
18	478.245.646	Weldment knife section left	VQ2516 from SN H215016	0	1	0
	478.245.642.	Weldment knife section left	VQ2516 till SN H215005	0	1	0
	478.245.384	Weldment knife section left	VQ2510 from SN A192212	1	0	0
	478.245.382	Weldment knife section left	VQ2510 till SN A192212	1	0	0
	478.245.906	Weldment knife section left	VQ2521 from SN H215022	0	0	1
	478.245.902	Weldment knife section left	VQ2521till SN. A124215	0	0	1
19	468.201.450	Distance plate		8	8	8
20	741.500.550	Bearing UCF 210		2	2	2
21	802.141.000	Bolt M14 x 100 - ISO 4014		8	8	8
22	804.120.350	Bolt M12 x 35 - ISO 4017		8	8	8
23	864.120.030	Washer M12 - ISO 7089		8	8	8
24	880.060.100	Grease nipple M6 DIN 71412A		2	2	2

# IMPORTANT!

Check machine,  
if different: see  
page 03

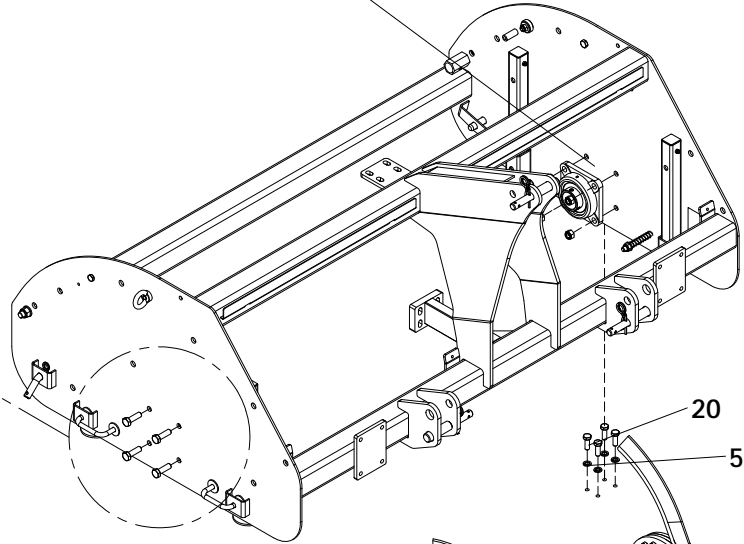
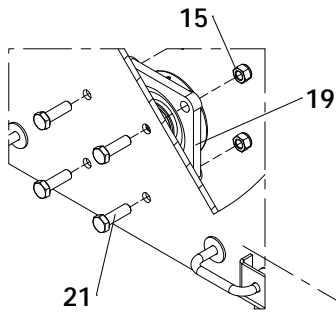
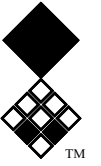

Knife sections at 60° interval

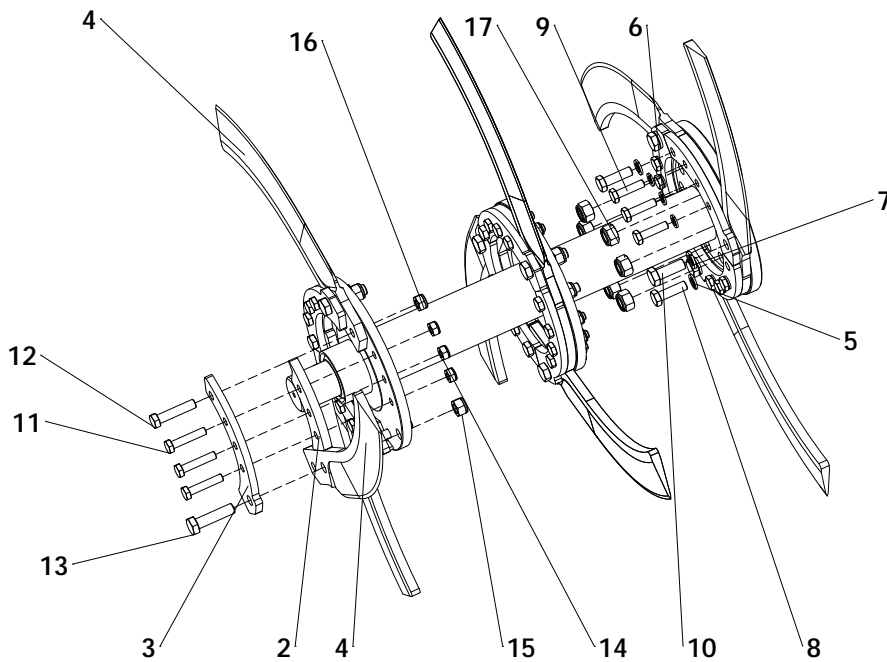
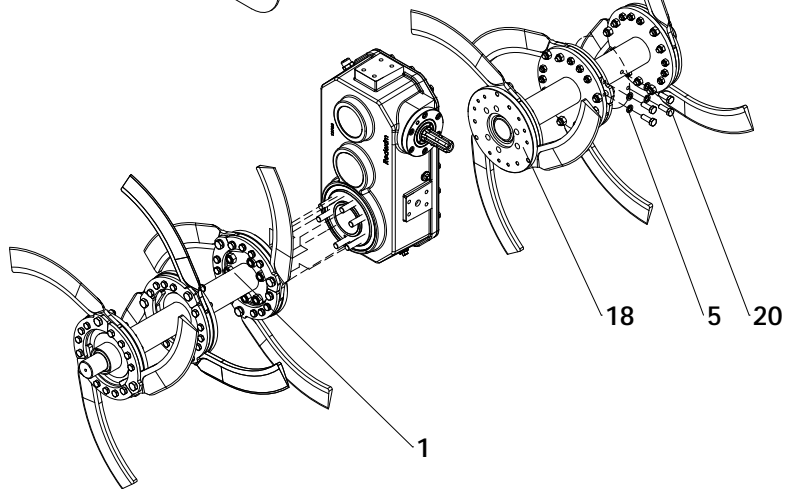
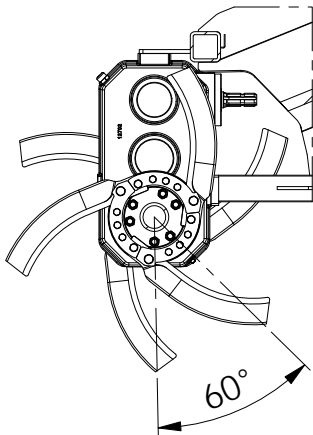

ITEM	PART NUMBER	DESCRIPTION	REMARKS	QUA VQ 2510	QUA VQ 2516	QUA VQ 2521
1	478.245.440	Weldment knife section right	Verti-Quake 2510	1	0	0
	478.245.700	Weldment knife section right	Verti-Quake 2516	0	1	0
	478.245.960	Weldment knife section right	Verti-Quake 2521	0	0	1
2	468.121.190	Fill plate		12	18	24
3	468.101.790	Lock plate		12	18	24
4	I005112R	Blade VQ25		12	18	24
4a	311.320.421	Blade VQ25 20mm	Sandmaster	0	18	0
4b	311.315.421	Blade VQ25 15mm		12	18	24
5	866.120.020	Spring Washer M12 - DIN 127		14	14	14
6	866.100.020	Spring Washer M10 - DIN 127		18	18	18
7	866.140.020	Spring Washer M14 - DIN 127		6	6	6
8	804.120.400	Bolt M12 x 40 - ISO 4017		6	6	6
9	804.100.400	Bolt M10 x 40 - ISO 4017		18	18	18
10	804.140.400	Bolt M14 x 40 - ISO 4017		6	6	6
11	802.100.500	Bolt M10 x 50 - ISO 4014		24	36	48
12	802.120.550	Bolt M12 x 55 - ISO 4014 - 10.9		6	12	18
13	802.140.550	Bolt M14 x 55 - ISO 4014 - 10.9		6	12	18
14	830.100.100	Self Lock Nut M10 - ISO 10511		24	36	48
15	830.140.140	Self Lock Nut M14 - ISO 10511		14	20	26
16	830.120.120	Self Lock Nut M12 - ISO 10511		6	12	18
17	826.160.160	Nut M16 - DIN 934		12	12	12
18	478.245.442	Weldment knife section left	Verti-Quake 2510	1	0	0
	478.245.702	Weldment knife section left	Verti-Quake 2516	0	1	0
	478.245.962	Weldment knife section left	Verti-Quake 2521	0	0	1
19	741.500.550	Bearing UCF 210		2	2	2
20	804.120.350	Bolt M12 x 35 - ISO 4017		8	8	8
21	804.140.450	Bolt M14 x 45 - ISO 4017		8	8	8

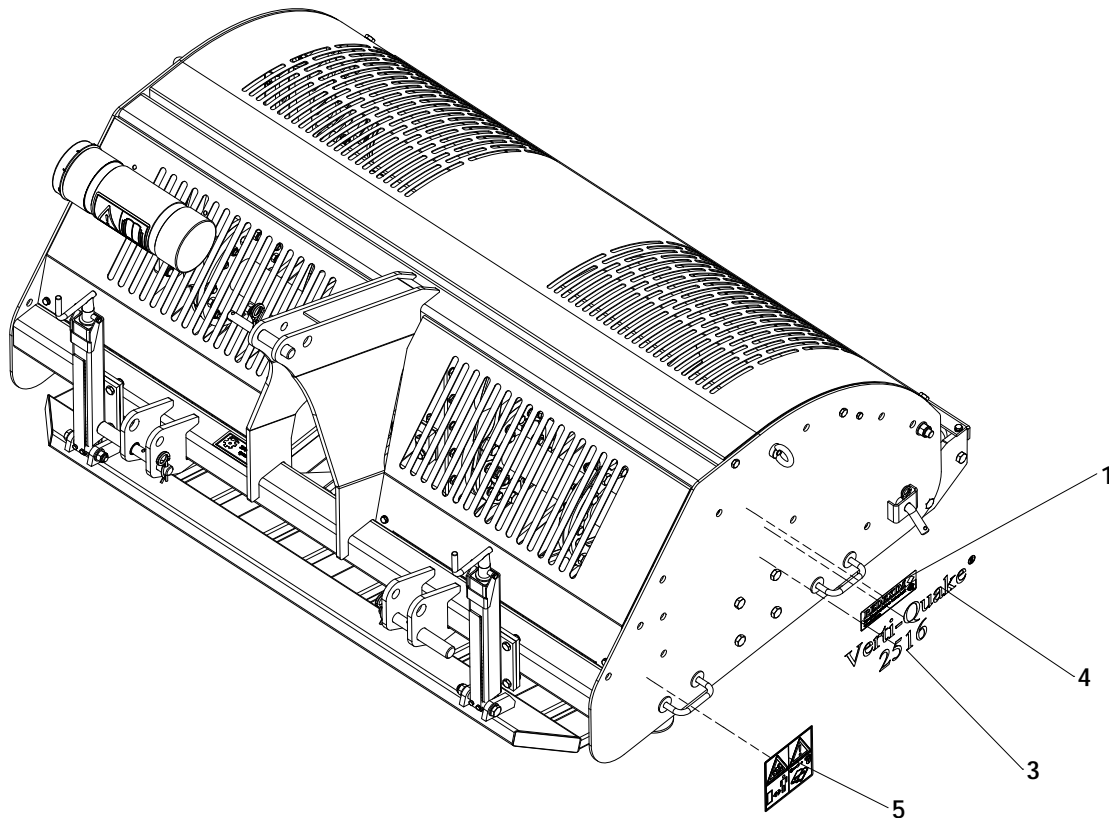
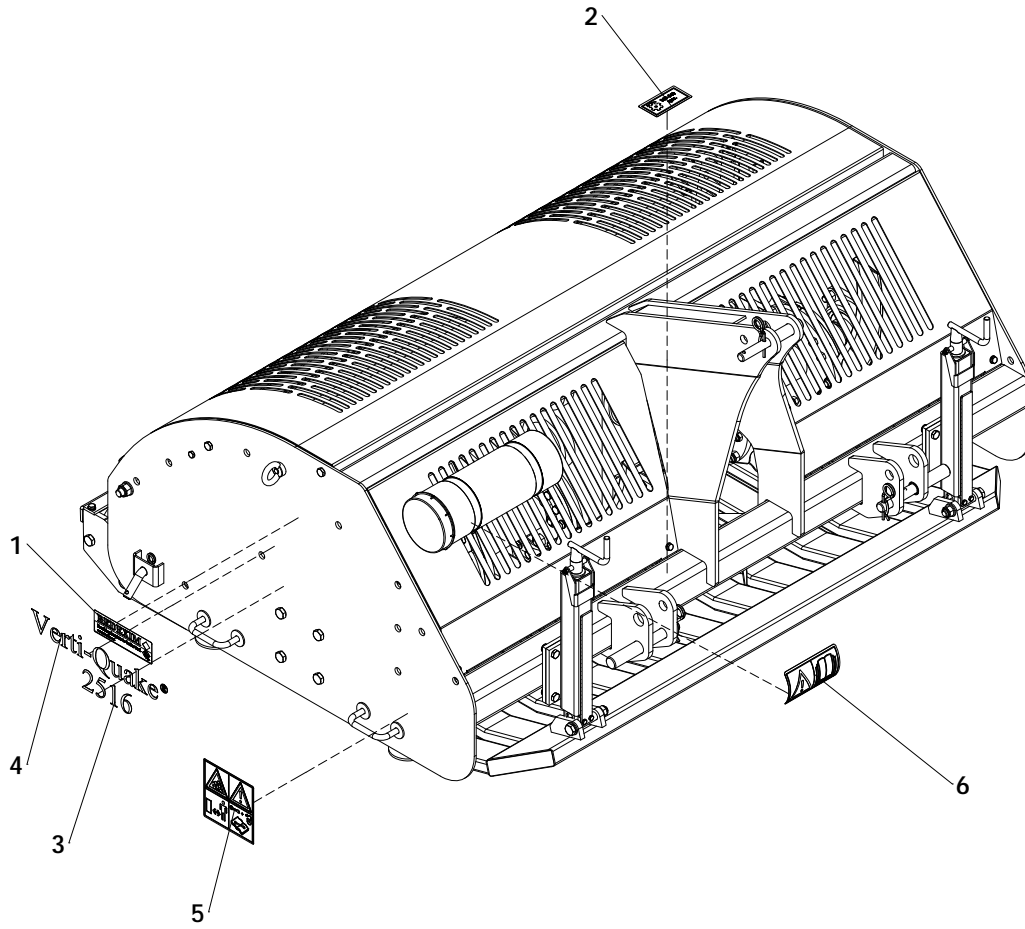



ITEM	PART NUMBER	DESCRIPTION	REMARKS	QUA VQ 2510	QUA VQ 2516	QUA VQ 2521
1	900.260.403	Logo Label Rev.B		2	2	2
2	900.260.422	Decall PTO 350 540		1	1	1
3	915.260.406	Decall 2510	Verti-Quake 2510	2	0	0
	915.260.403	Decall 2516	Verti-Quake 2516	0	2	0
	915.260.404	Decall 2521	Verti-Quake 2521	0	0	2
4	915.260.200	Decall Verti-Quake 50mm		2	2	2
5	921.280.402	Safety decall VS		2	2	2
6	900.280.402	Safety decall manual		1	1	1
7	804.080.160	Bolt M8 x 16 - ISO 4017		4	4	4

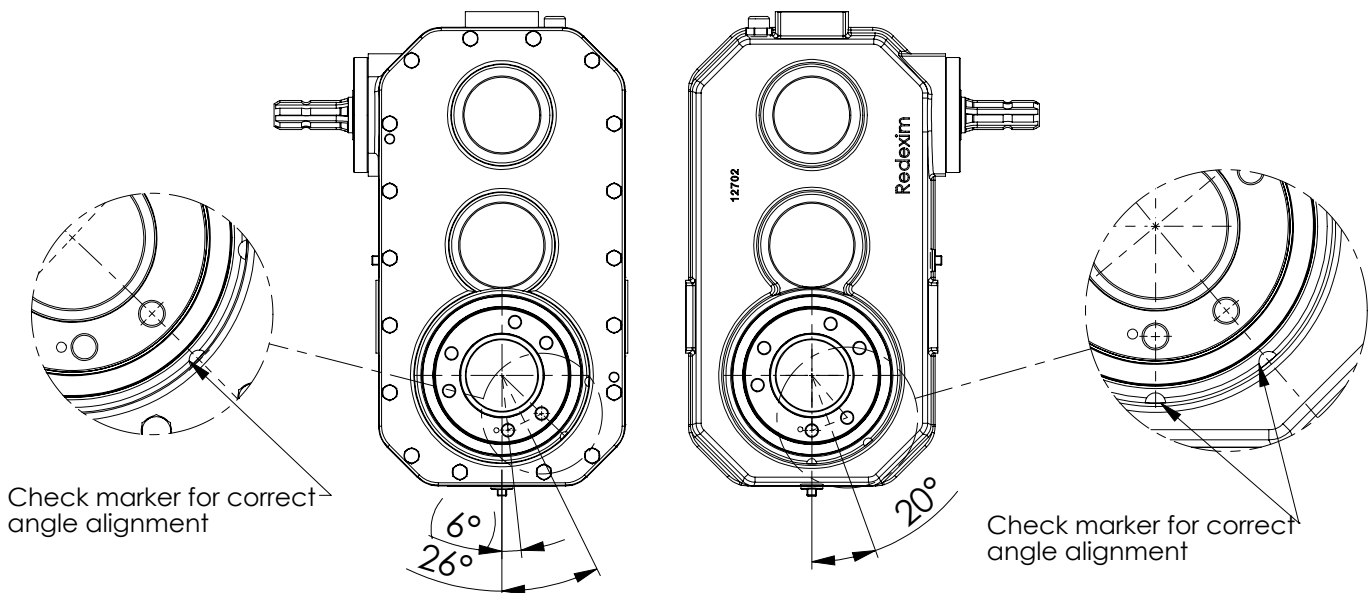
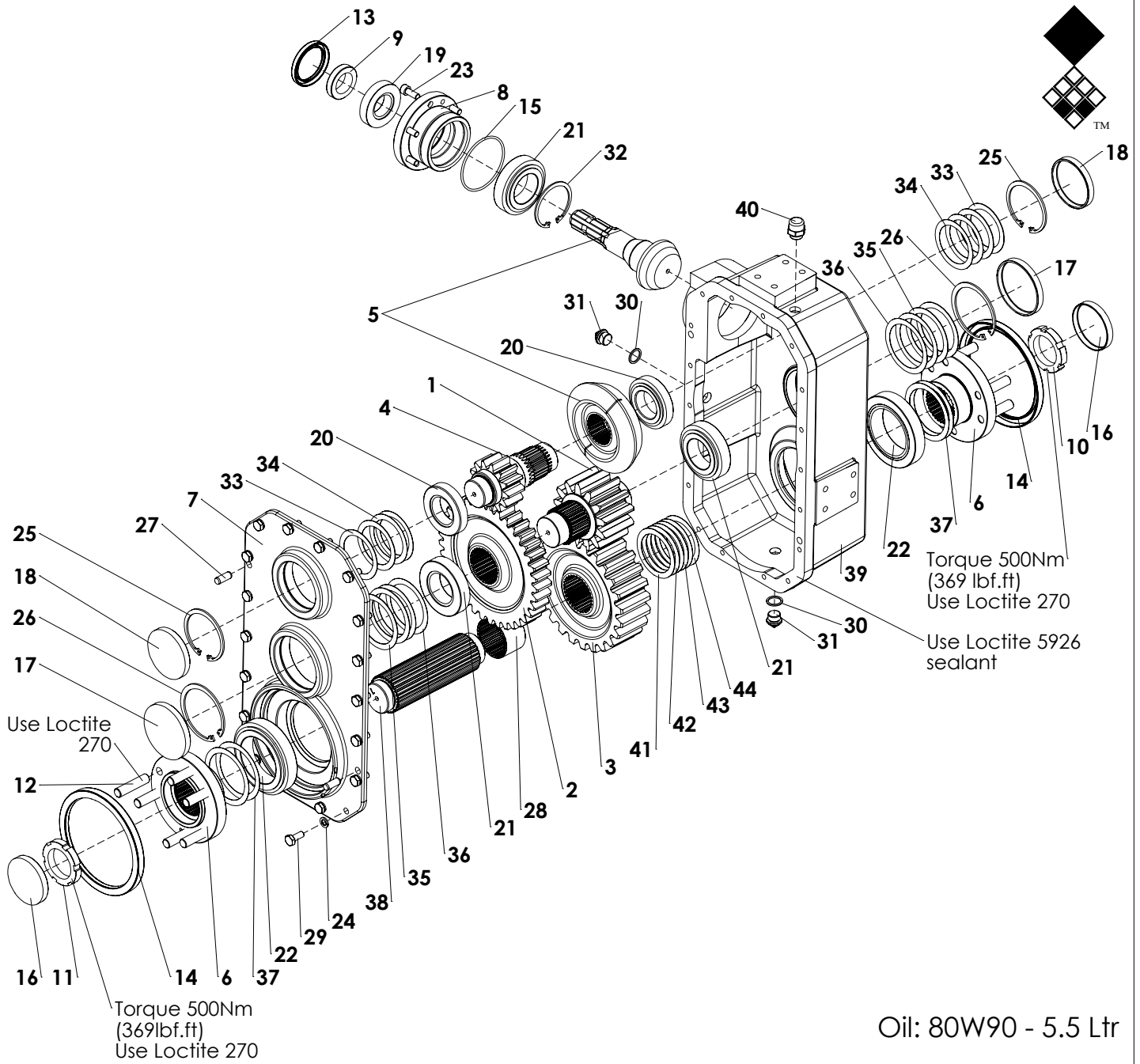

ITEM	PART NUMBER	DESCRIPTION	REMARKS	QUA VQ 2510	QUA VQ 2516	QUA VQ 2521
1	12694	Gear Z12 - m8.5	Till serial no: H215005	1	1	1
	432.551.260	Gear Z13 - m8	From serial no: H215005	1	1	1
2	12695	Gear Z37 - m6		1	1	1
3	12698	Gear Z25 - m8.5	Till serial no: H215005	1	1	1
	432.622.130	Gear Z24 - m8	From serial no: H215005	1	1	1
4	12699	First shaft with gear Z13 - m6		1	1	1
5	432.991.650	Crown and pignon set		1	1	1
6	12701	Flange for transmission		2	2	2
7	12705	Cover		1	1	1
8	12707	Pinion flange		1	1	1
9	12708	Nut on pinion M40x1,5		1	1	1
10	12709-Dx	Nut M55x1.5 Right thread		1	1	1
11	5001182	Nut M55x1.5 Left thread		1	1	1
12	4091598	Stud		12	12	12
13	4408930	Seal 60x80x10		1	1	1
14	4411080	Seal Ø160xØ190x15		2	2	2
15	4424362	O-Ring Ø91.97x3.53		1	1	1
16	4480009	End cap 85x10		2	2	2
17	4480019	End cap 100x10		2	2	2
18	4480048	End cap 90x10		2	2	2
19	725.400.200	Bearing 30208		1	1	1
20	725.500.220	Bearing 30210		2	2	2
21	725.550.270	Bearing 32211		3	3	3
22	725.850.290	Bearing 32017		2	2	2
23	814.100.250	Bolt M10 x 25 - DIN 912		6	6	6
24	866.100.020	Spring Washer M10 - DIN 127		18	18	18
25	872.090.300	Circlip D=90 - DIN 472		2	2	2
26	872.100.300	Circlip D=100 - DIN 472		2	2	2
27	890.120.300	Parallel Pin ISO 8734 - 12x30		2	2	2
28	5001852	Distance bush		1	1	1
29	804.100.250	Bolt M10 x 25 - ISO 4017		18	18	18
30	874.210.020	Copper washer 1_2		2	2	2
31	4561000	Tap 1/2"		2	2	2
32	872.080.250	Circlip D=80 - DIN 472		1	1	1
33	868.090.100	DIN 988 Shim 90x70x1	Quantity depending on play			
34	868.090.050	DIN 988 Shim 90x70x0.5	Quantity depending on play			
35	868.100.100	DIN 988 Shim 100x80x1	Quantity depending on play			
36	868.100.050	DIN 988 Shim 100x80x0.5	Quantity depending on play			
37	868.105.050	DIN 988 Shim 105x85x0.5	Quantity depending on play			
38	5001717	Axle		1	1	1
39	12702	Gearbox housing		1	1	1
40	537.120.300	Breather 1/2"		1	1	1
41	868.090.100	DIN 988 Shim 90x70x1	Quantity depending on play			
42	868.090.030	DIN 988 Shim 90x70x0.3	Quantity depending on play			
43	868.090.020	DIN 988 Shim 90x70x0.2	Quantity depending on play			
44	868.090.010	DIN 988 Shim 90x70x0.1	Quantity depending on play			
	1441850	Gearbox complete				

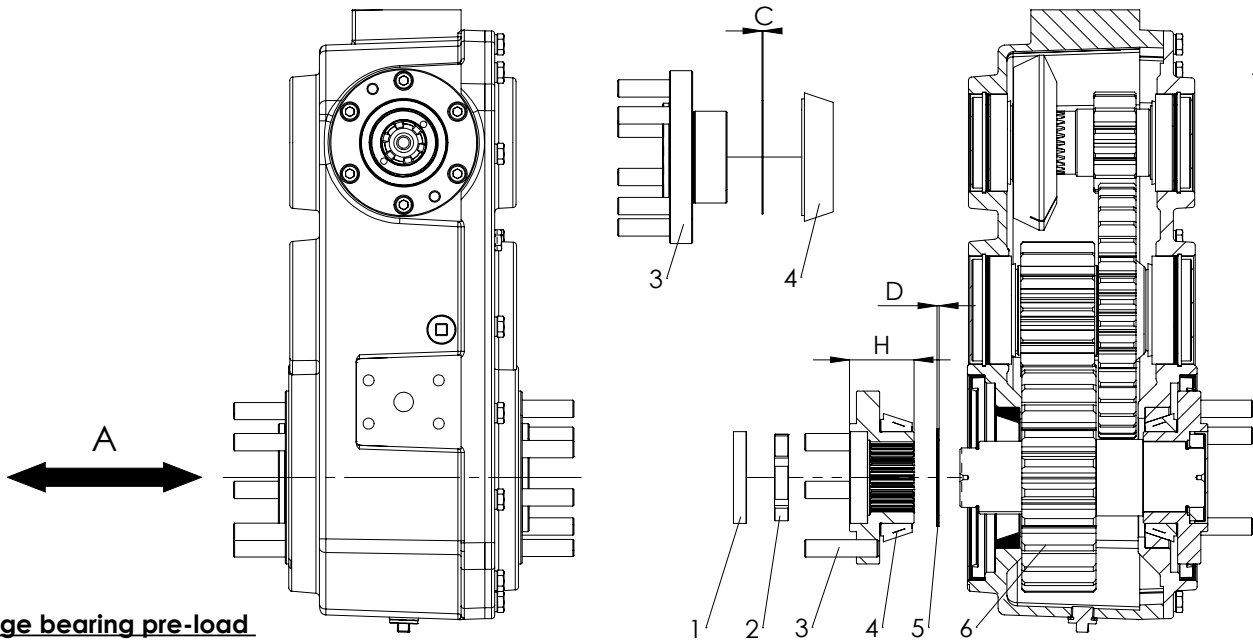

**Flange bearing pre-load**

1. Remove the oil.
2. Place the gearbox stable on its front side, with the PTO shaft side facing upwards.
3. Remove end cap 1 + nut 2 + flange hub 3 from the housing side of the gearbox.
4. Measure the height "H" of flange hub 3.
  - Height "H" is 60.8mm(2.39") proceed to point 5.
  - Height "H" is 59.8mm(2.35") proceed to point 13.
5. Place an extra shim of 1mm (0.04") (Part.no. 868.090.100) between the flange hub 3 and the gear 6 to gain positive play.
6. Mount flange hub 3 and fasten nut 2.
7. Measure the axial clearance "A" of the output shaft by shifting it sideways.
8. Calculate the positive axial clearance:
  - $A - 0.7mm(0.028") = \text{Desired thickness of shims to add to shim package "C"}$ .

**Pre-load on the tapered bearings should be in the range of 0.2-0.3mm (0.008"-0.012")**
9. Remove nut 2, flange hub 3 and extra shim of 1mm (0.04") (Part.no. 868.090.100).
10. Remove the flanged bearing 4 from the flanged hub.
11. Place the correct thickness of shim package "C" as determined in point 8 between the bearing and the hub. (Standard 2x shims (7) of 0.5mm(0.019") are placed in this position)
12. Proceed to step 19.
13. Place an extra shim of 1mm (0.04") (Part.no. 868.090.100) between the flange hub (3) and the shims (5) placed on gear (6) to gain positive play.
14. Mount flange hub 3 and fasten nut 2.
15. Measure the axial clearance "A" of the output shaft by shifting it sideways.
16. Calculate the positive axial clearance:
  - $A + 0.3mm(0.012") = \text{Desired thickness of shims to remove from shim package "D" (included the extra shim of 1mm (0.04"))}$ .

**Pre-load on the tapered bearings should be in the range of 0.2-0.3mm (0.008"-0.012")**
17. Remove nut 2, flange hub 3.
18. Place the correct thickness of shim package "D" as determined in point 16 between the hub and the gear.
19. Check the correct timing and place flange hub 3.
20. Apply nut 2 and fasten. There should now be no axial play. When correct remove nut 2 and proceed to step 21 if not re-check as described from point 7.
21. Apply nut 2 with loctite 270 and fasten with 500Nm (369 lbf.ft.)
22. Apply end cap 1.
23. Place gearbox upright and fill up with oil SAE 80W90 5.5L (1.45 gallon).

**Timing**

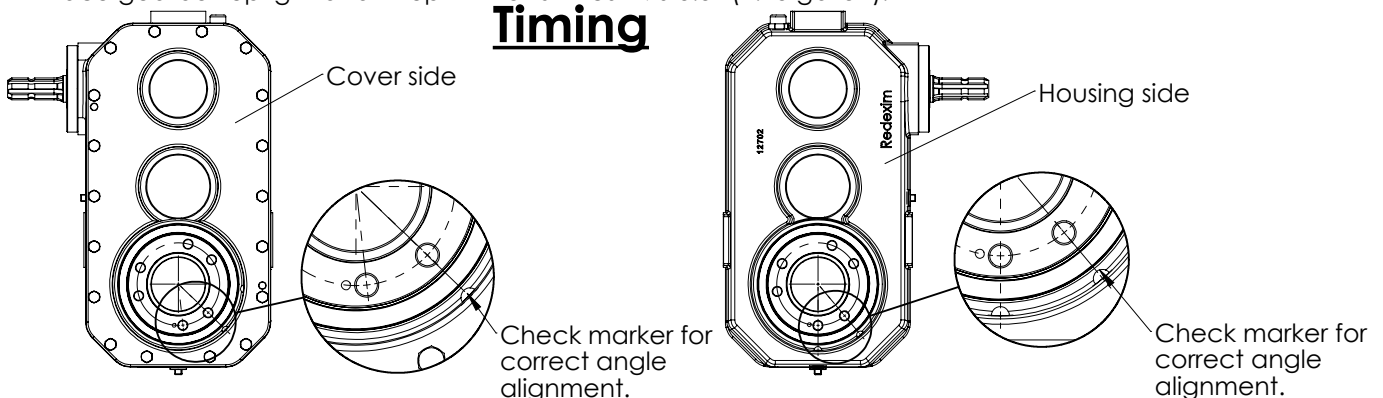



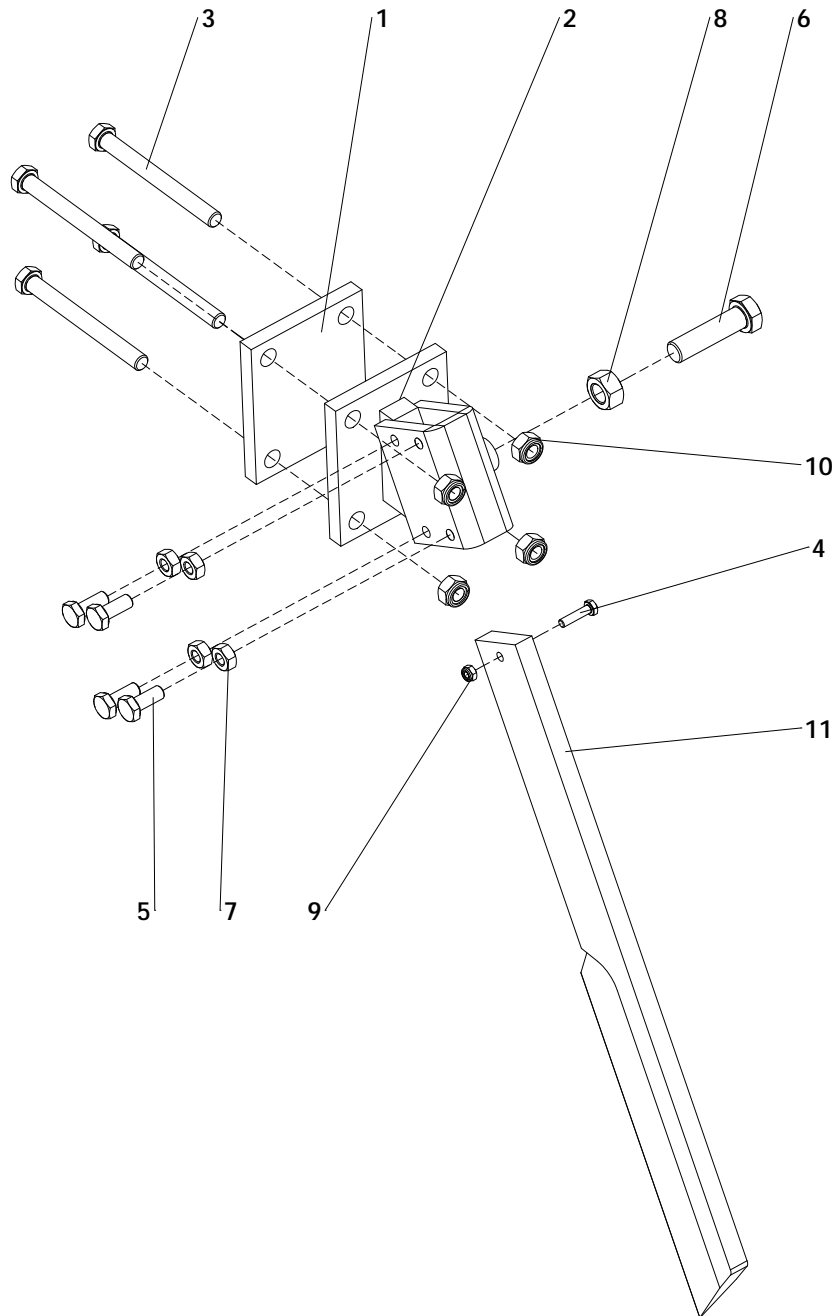
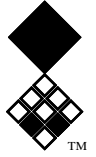

Optional

ITEM	PART NUMBER	DESCRIPTION	REMARKS	QUA
1	464.121.000	Strip		1
2	466.121.000	Coulterknife bracket		1
3	802.121.200	Bolt M12 x 120 - ISO 4014		4
4	804.060.250	Bolt M6 x 25 - ISO 4017		1
5	804.100.250	Bolt M10 x 25 - ISO 4017		4
6	804.160.600	Bolt M16 x 60 - ISO 4017		1
7	826.100.100	Nut M10 - DIN 934		4
8	826.160.160	Nut M16 - DIN 934		1
9	830.060.060	Self Lock Nut M6 - ISO 10511		1
10	830.120.120	Self Lock Nut M12 - ISO 10511		4
11	I005130R	Coulterknife		1
	215.100.002	Coulterknife set complete	Verti-Quake 2510	
	215.160.002	Coulterknife set complete	Verti-Quake 2516	
	215.210.002	Coulterknife set complete	Verti-Quake 2521	

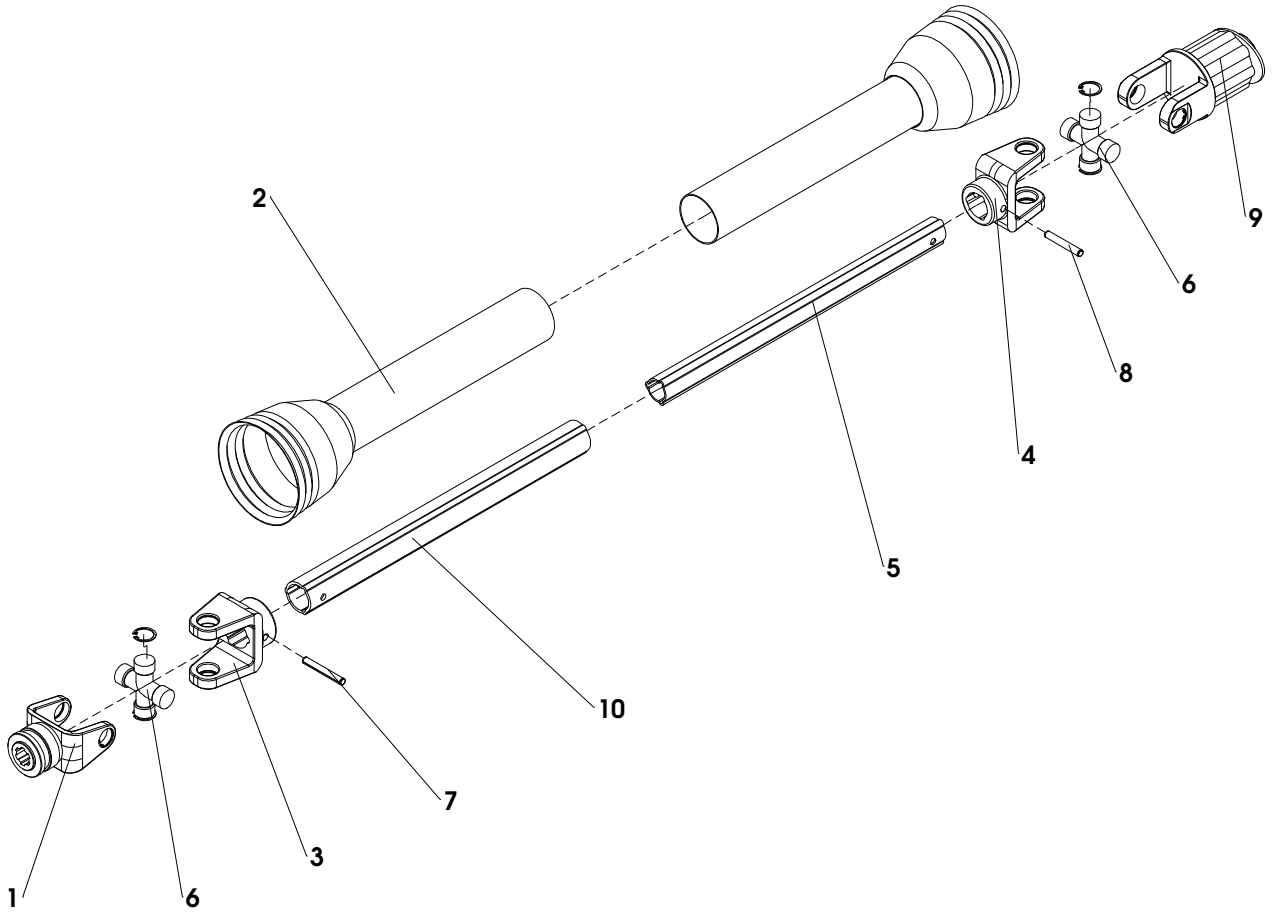



ITEM	PART NUMBER	DESCRIPTION	REMARKS	QUA
1	141024430	Complete collar yoke		1
2	1423400087450	Complete shield		1
3	151014006	Outer tube yoke		1
4	151014007	Inner tube yoke		1
5	153140108	T-series Inner tube		1
6	180014130	Cross and 4x circlip kit		2
7	190000014	Outer roll pin		1
8	190000012	Inner roll pin		1
9	190000582	Ractchet Clutch U34		1
10	1521402080730	T-series Outer tube		1
	613.616.092	PTO Complete		