

AgriMetal

PARTS LIST

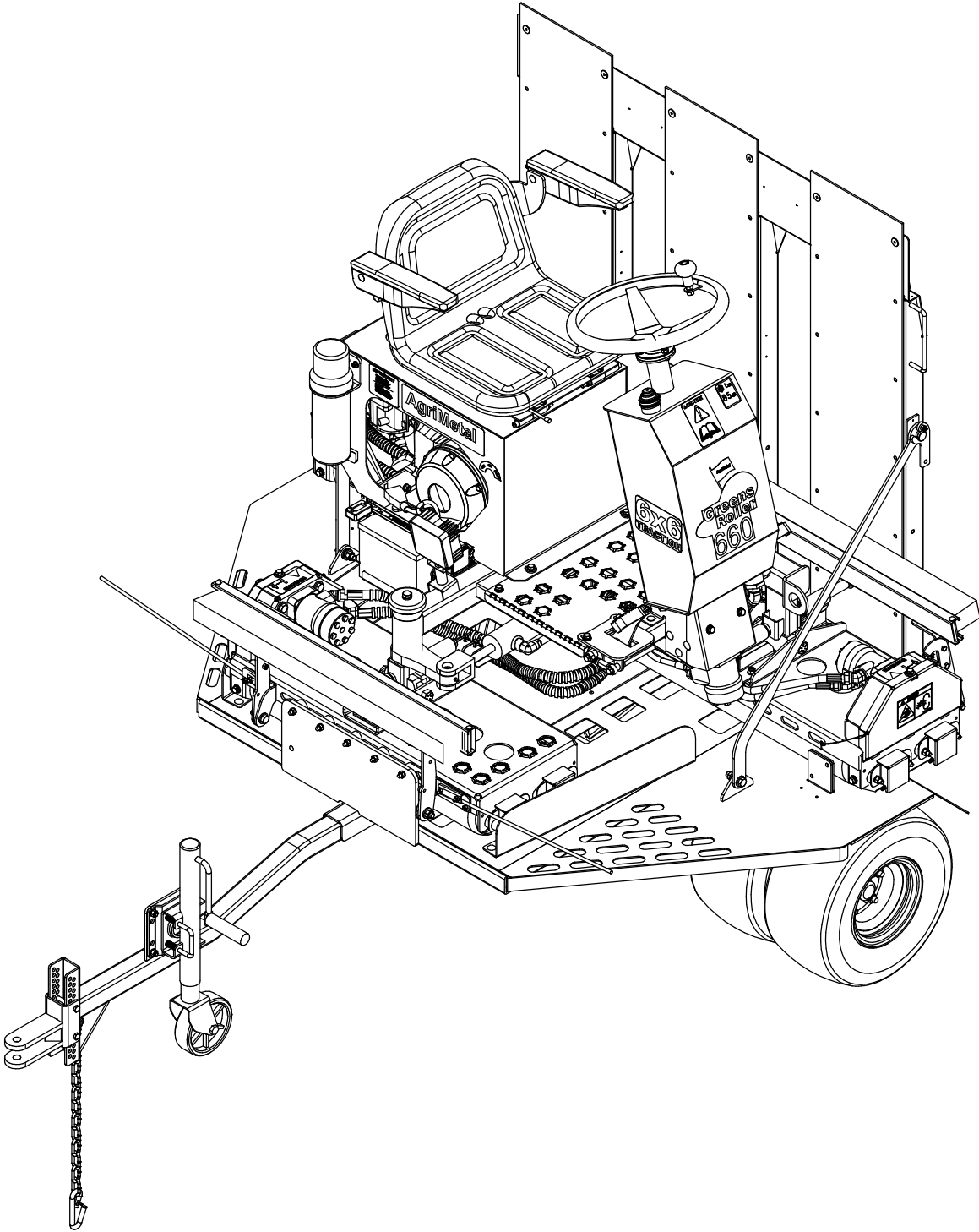

GR 660-F (4 WHEELS)

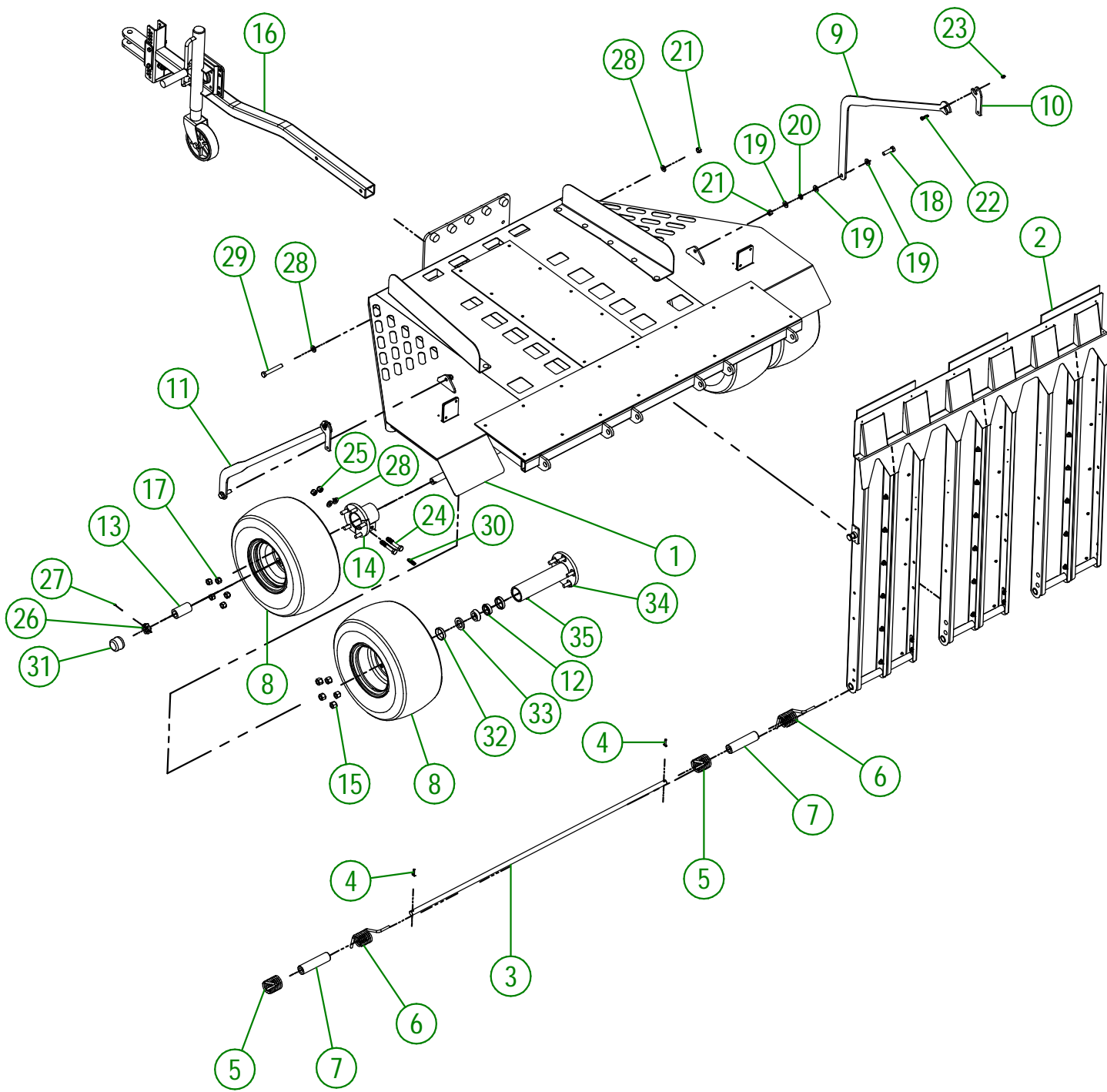

AGRIMETAL	
TRAILER (4 WHEELS) & PALLET OF TRANSPORT	
CREATION : 20/02/20	ASSEMBLY : 39-55-0350
REVISION : 09/02/22	AUTHOR : D. Bevins

39-55-0350

#	PART #	Qty	TITLE
1	39-57-0350	1	TRAILER (4 WHEELS)
2	39-55-0306	1	RAMP
3	39-13-1010	1	PIVOT RAMP
4	NC01-69-0159	2	COTTER PIN ZINC 3/16 X 1 1/2"
5	NC13-85-0054	2	TRAILER RAMP SPRING
6	NC13-85-0053	2	TRAILER RAMP SPRING
7	39-42-0120	2	SPRING BUSHING
8	NC14-70-0641	4	TRAILER WHEEL
9	39-04-0356	1	RAMP LOCK (RIGHT) GR660-E
10	39-04-0360	2	DOOR LOCK
11	39-04-0358	1	RAMP LOCK (LEFT) GR660-E
12	NC14-70-0093	5	EXTERIOR BEARING
13	39-09-0015	2	WHEEL AXLE RING
14	39-50-0350	2	WHEEL HUB
15	39-25-0005	10	INTERIOR WHEEL HUB NUT
16	39-55-0313	1	PRE-ASSEM. TONGUE
17	NC02-12-0005	10	HEX. NUT ZINC 1/2-20
18	NC01-17-0250	2	HEX. BOLT GR2 ZINC 1/2-13 X 1 3/4"
19	NC02-25-0011	6	WASHER SAE ZINC 17/32 ID
20	NC02-32-0014	2	LOCK WASHER ZINC 1/2"
21	NC01-96-0014	5	NYLON-INSERT LOCKNUT ZINC 1/2-13
22	NC01-29-0006	2	HEX. BOLT GR5 NF ZINC 1/4-28 X 1 1/2"
23	NC01-97-0004	2	NYLON-INSERT LOCKNUT ZINC 1/4-28
24	NC01-29-0255	4	HEX. BOLT GR2 ZINC 1/2-13 X 3"
25	NC01-97-0008	4	HEX. LOCK NUT NYLO. NF Z 1/2-20
26	NC14-70-0310	2	SLOTTED NUT 1-14
27	NC14-70-0311	2	COTTER PIN ZINC 5/32" X 2"
28	01-01-0925	9	WASHER
29	NC01-17-0257	3	HEX. BOLT GR2 ZINC 1/2-13 X 3 1/2"
30	39-30-0000	2	PULLER
31	NC14-70-0092	2	DUST GUARD
32	NC14-70-0090	4	EXTERIOR BEARING CAGE
33	NC14-70-0324	2	GASKET 1.219" X 1.980"
34	39-50-0345	2	WHEEL HUB
35	NC01-69-0785	2	STRAIGHT GREASE FITTING 1/4-28

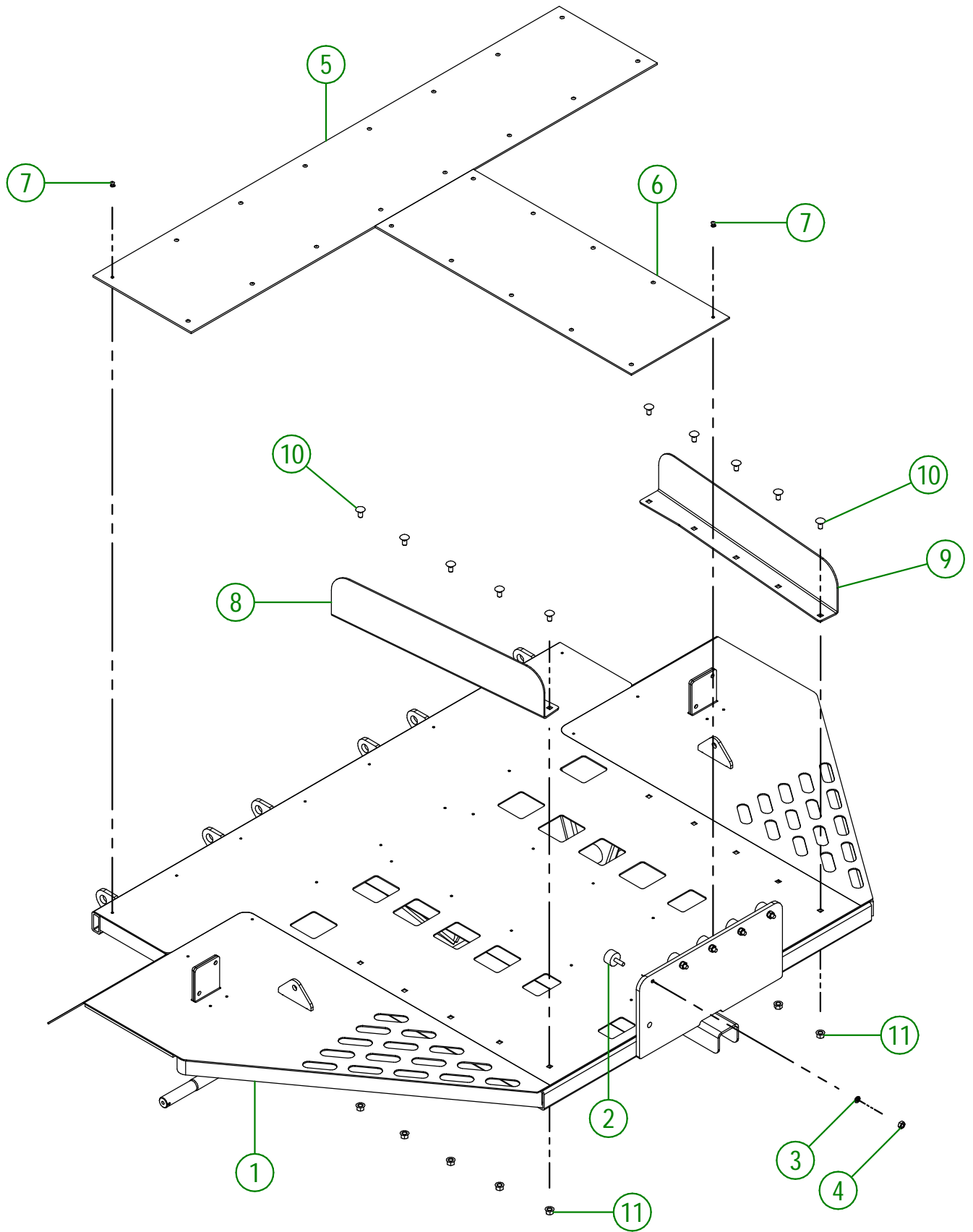

AGRIMETAL	
TRAILER (4 WHEELS)	
CREATION : 20/02/20	ASSEMBLY : 39-57-0350
REVISION : 20/12/21	AUTHOR : D. Bevins

39-57-0350

#	PART #	Qty	TITLE
1	39-50-0302	1	TRAILER (4 WHEELS)
2	NC13-15-0034	5	RUBBER ABSORBER
3	NC02-32-0011	5	LOCK WASHER ZINC 5/16"
4	NC02-07-0017	5	HEX. NUT 5/16-18
5	39-42-0037	1	TRAILER RUBBER (BEHIND)
6	39-42-0042	1	TRAILER RUBBER (CENTER)
7	NC01-78-0300	26	RIVETS AC. AV. SUPR. TI. AC. .187 X .515 CAP. RIVET .270
8	39-01-0200	1	POSITIONING GUIDE (RIGHT) GR660-E
9	39-01-0205	1	POSITIONING GUIDE (LEFT) GR660-E
10	NC01-04-0107	10	CARR. BOLT GR2 ZINC 3/8-16 X 3/4"
11	NC02-14-0019	10	FLANGE NUT HEX. NC 3/8-16 GR. B

#	PART #	Qty	TITLE
1	39-50-0326	1	TRAILER TONGUE
2	33-50-0055	1	WELD ASSEMBLY HAND
3	NC01-17-0123	2	HEX. BOLT GR2 ZINC 3/8-16
4	NC02-32-0012	6	LOCK WASHER ZINC 3/8"
5	NC02-07-0018	6	HEX. NUT ZINC 3/8-16
6	NC01-17-0116	1	HEX. BOLT GR2 ZINC 3/8-16 X 1 1/2"
7	21-01-0950	4	FLAT WASHER IOGA 1.005" DIA X 25/64"
8	55-41-0000	1	SAFETY CHAIN
9	NC01-96-0011	1	NYLON NUT 3/8-16
10	39-55-0330	1	ADJUSTABLE WHEEL CRUTCH
11	NC01-04-0109	4	CARR. BOLT GR2 ZINC 3/8-16 X 1"

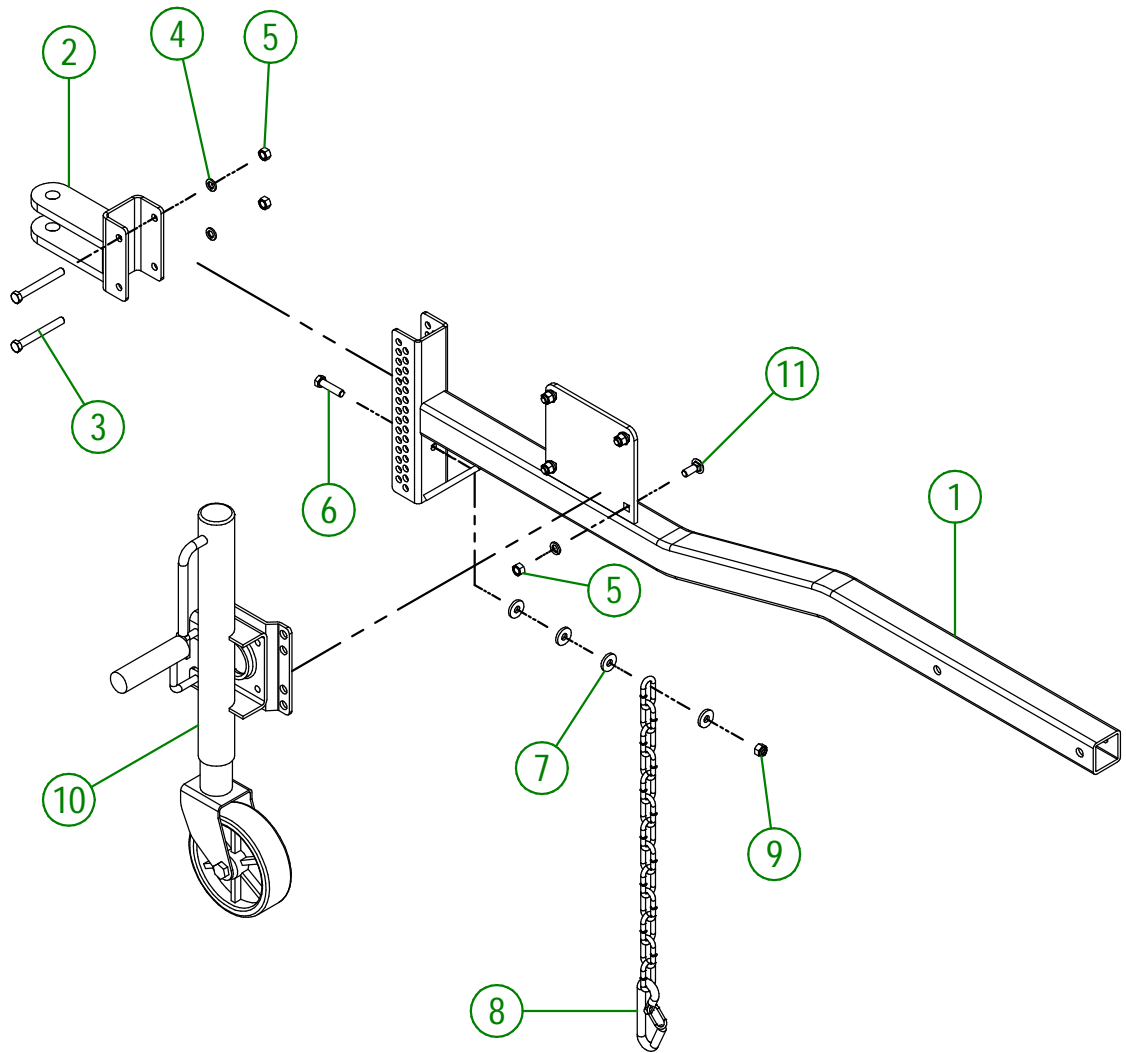

AGRIMETAL
PRE-ASSEM. TONGUE

CREATION : 12/02/20
REVISION : 06/12/21

ASSEMBLY : **39-55-0313**
AUTHOR : D. Bevins

39-55-0306

#	PART #	Qty	TITLE
1	39-50-0307	1	RAMP
2	39-42-0031	3	RAMP RUBBER
3	NC01-78-0016	6	ALUMINIUM BLIND POP RIVET STEEL MANDREL 0.187 X 0.690
4	NC01-78-0300	36	RIVETS AC. AV. SUPR. TI. AC. .187 X .515 CAP. RIVET .270
5	39-01-0170	4	TRAILER RAMP REINFORCEMENT
6	NC01-04-0055	8	CARR. BOLT GR2 ZINC 5/16-18 X 5/8"
7	NC02-14-0006	8	HEX. NUT SPECIAL FLANGET NC 5/16-18 B GRADE
8	16-01-2720	6	WASHER 13/16" DIA. X 13/64"

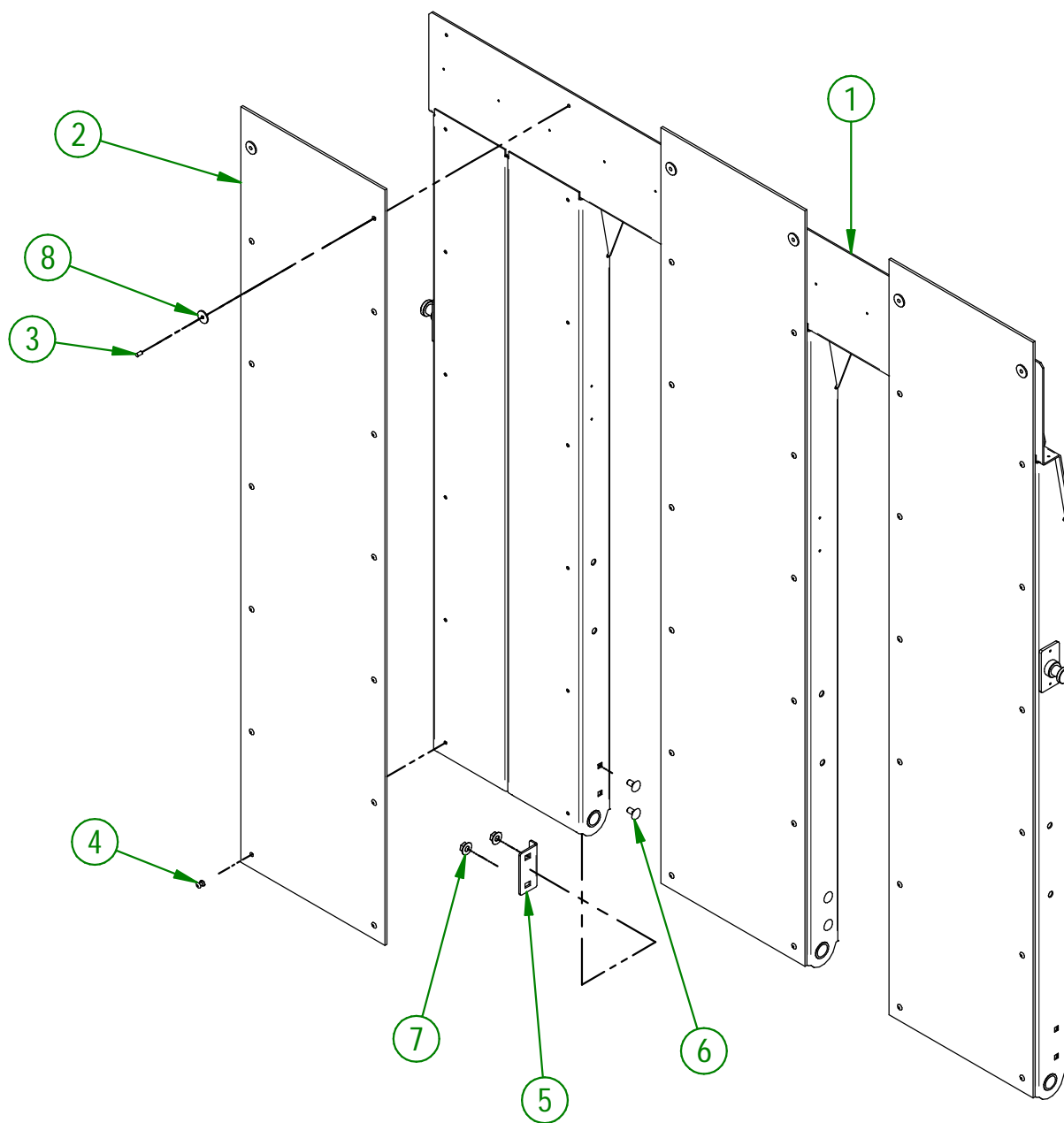

AGRIMETAL
RAMP

CREATION : 13/02/20
REVISION : 20/12/21

ASSEMBLY : **39-55-0306**
AUTHOR : D. Bevins

#	PART #	Qty	TITLE
1	39-50-0001	1	FRAME
2	NC13-15-0034	2	RUBBER ABSORBER
3	NC13-25-0378	2	WHITE METAL CONNECTOR
4	39-21-0200	1	HYDRAULIC DISPENSING BLOCK
5	NC13-45-0221	2	HEXAGONAL PLUG
6	NC01-17-0119	2	HEX. BOLT GR2 ZINC 3/8-16 X 2 1/4"
7	NC02-32-0012	10	LOCK WASHER ZINC 3/8"
8	NC02-07-0018	4	HEX. NUT ZINC 3/8-16
9	01-01-2485	6	FLAT WASHER 14 GA X 13/16"OD X 25/64" ID
10	NC01-17-0112	2	HEX. BOLT GR2 ZINC 3/8-16 X 3/4"
11	NC01-17-0114	4	HEX. BOLT GR2 ZINC 3/8-16 X 1"
12	NC02-32-0011	4	LOCK WASHER ZINC 5/16"
13	NC02-07-0017	2	HEX. NUT 5/16-18
14	39-04-0186	1	STOPPER PLATE FOR PEDAL (RIGHT)
15	39-04-0188	1	STOPPER PLATE FOR PEDAL (LEFT)
16	39-57-0125	1	FOOTBOARD "STICKER INCLUDED"
17	39-50-0020	1	OIL FILTER HOLDER
18	NC01-17-0060	2	HEX. BOLT GR2 ZINC 5/16-18 X 1"
19	NC01-04-0109	2	CARR. BOLT GR2 ZINC 3/8-16 X 1"

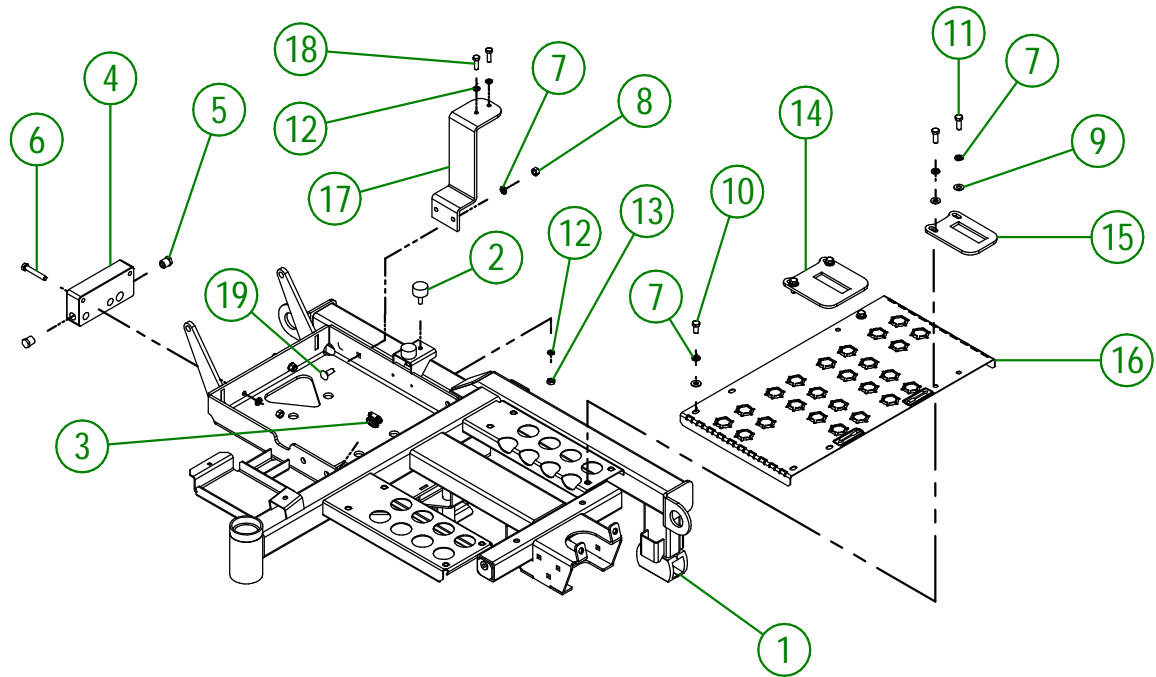

AGRIMETAL
FRAME GROUP

CREATION : 07/05/20
REVISION : 20/12/21

ASSEMBLY : **39-57-0002**
AUTHOR : D. Bevins

39-57-0104

#	PART #	Qty	TITLE
1	39-55-0260	1	RIGHT ROLLER
2	39-09-1205	1	BUSHING
3	39-42-0700	1	PIVOTING BLOCK
4	NC01-37-0480	1	HEX. BOLT GR8 ZINC 3/4-16 X 5 1/2"
5	NC02-32-0017	1	LOCK WASHER ZINC 3/4"
6	NC02-11-0023	1	NUT 3/4-16

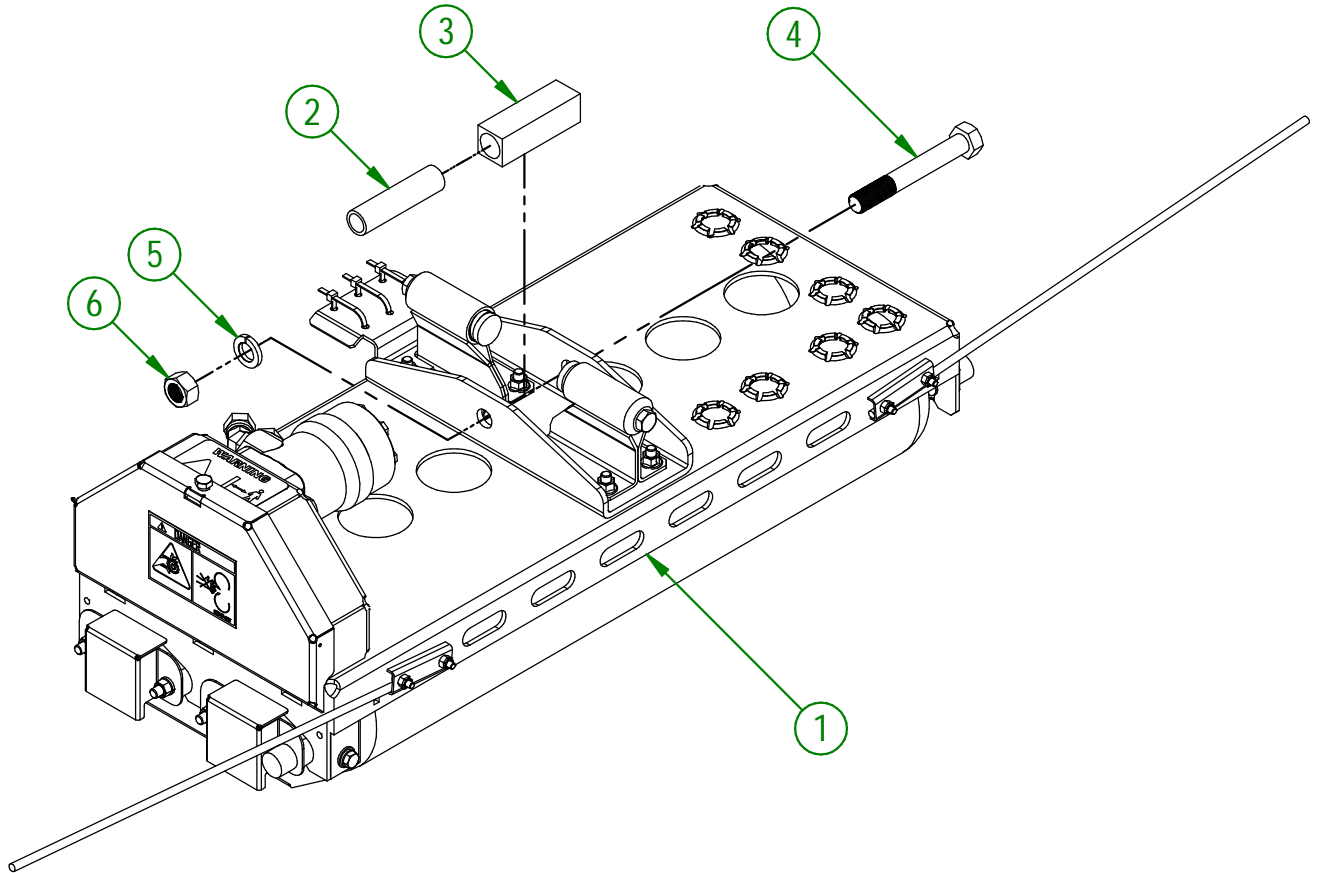

AGRIMETAL	
RIGHT ROLLER GROUP	
CREATION : 20/12/21	ASSEMBLY : 39-57-0104
REVISION : 20/12/21	AUTHOR : D. Bevins

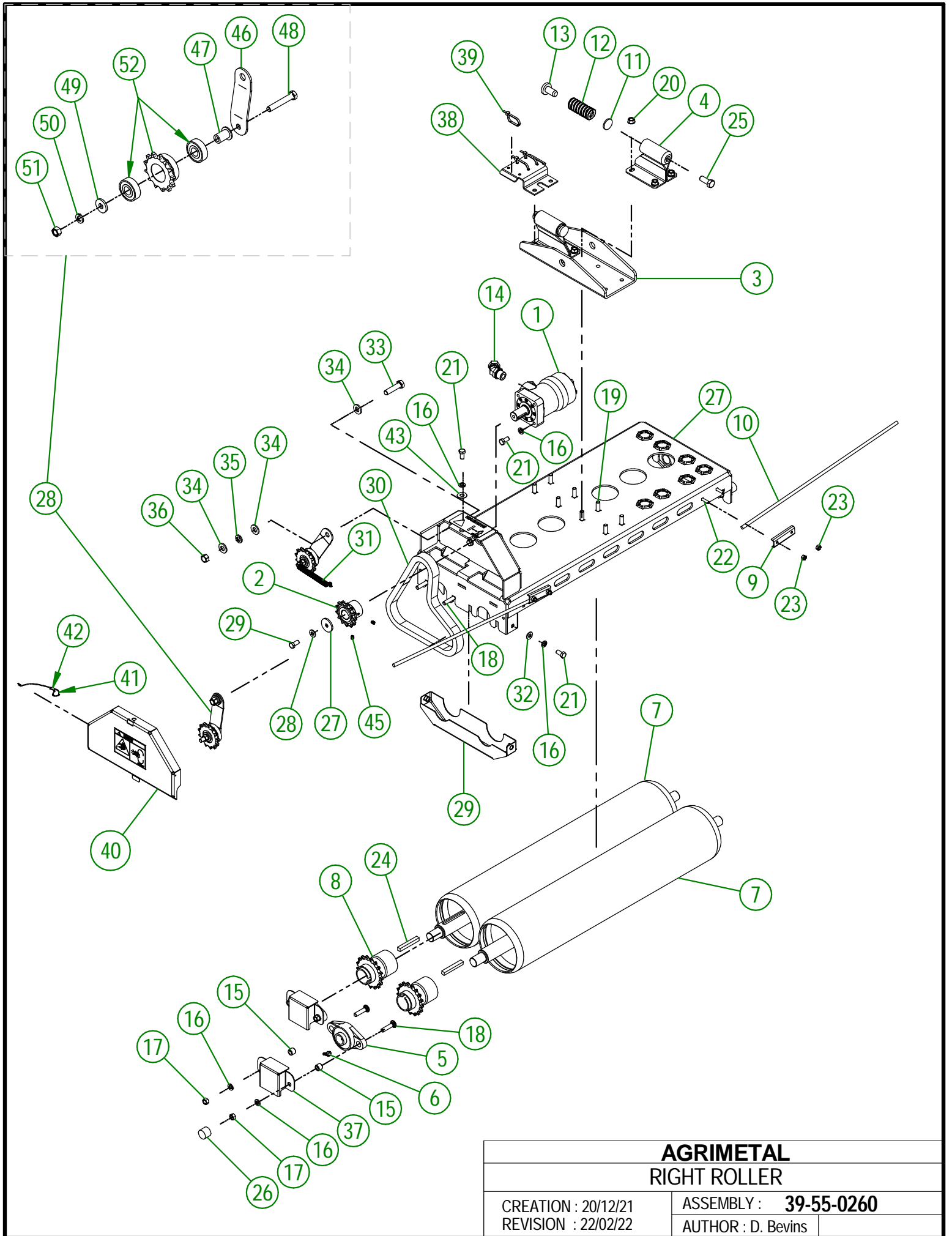

AGRIMETAL
RIGHT ROLLER

CREATION : 20/12/21
 REVISION : 22/02/22

ASSEMBLY : **39-55-0260**
 AUTHOR : D. Bevins

39-55-0260

#	PART #	Qty	TITLE
1	NC14-45-0041	1	100cc HYDRAULIC MOTOR
2	39-50-0057	1	HYDRAULIC MOTOR SPROCKET
3	39-04-0225	1	ROLLER SUPPORT
4	39-50-0045	2	SPRING GUIDE
5	NC14-75-0019	4	FLANGE PILLOW BLOCK BEARING UCFL205-16 Ø 1"
6	NC01-69-0802	4	GREASE FITTING 6mm X 45mm
7	39-50-0096	2	ROLLER (1 KW)
8	39-50-0052	2	ROLLER SPROCKET
9	39-01-2440	2	GUIDE ROD CLAMP
10	39-42-0600	2	GUIDE ROD
11	39-01-1000	2	SPRING GUIDE WASHER
12	NC13-86-0159	2	RED SPRING 1 1/4"OD X 5/8"ID X 2" LG
13	39-42-0100	2	SPRING TIP
14	NC13-45-0046	2	45°-7/8-14 MALE O RING X 1/2 FEM.TOUR.NPT PT
15	32-09-0000	4	BUSHING BEARING
16	NC02-32-0012	15	LOCK WASHER ZINC 3/8"
17	NC02-07-0018	8	HEX. NUT ZINC 3/8-16
18	NC01-04-0111	8	CARR. BOLT GR2 ZINC 3/8-16 X 1 1/2"
19	NC01-04-0110	8	CARR. BOLT GR2 ZINC 3/8-16 X 1 1/4"
20	NC02-14-0019	8	FLANGE NUT HEX. NC 3/8-16 GR. B
21	NC01-17-0112	8	HEX. BOLT GR2 ZINC 3/8-16 X 3/4"
22	NC01-04-0005	4	CARR. BOLT GR2 ZINC 1/4-20 X 1"
23	NC01-96-0009	4	NYLON-INSERT LOCKNUT ZINC 1/4-20
24	48-41-0905	2	SQUARE KEY 3/8" X 2 3/4" LG
25	NC01-17-0248	2	HEX. BOLT GR2 ZINC 1/2-13 X 1 1/4"
26	39-42-0110	2	ROLLER NUT CAP
27	39-57-0157	1	ROLLER HOUSING (RIGHT)
28	39-55-0160	2	CHAIN TENSIONER SPROCKET
29	39-50-0130	1	ROLLER CHAIN GUARD
30	39-37-0000	1	CHAIN
31	NC13-85-0058	1	CHAIN TENSIONER SPRING
32	01-01-2485	3	FLAT WASHER 14 GA X 13/16"OD X 25/64" ID
33	NC01-17-0251	2	HEX. BOLT GR2 ZINC 1/2-13 X 2"
34	NC02-25-0011	6	WASHER SAE ZINC 17/32 ID
35	NC02-32-0014	2	LOCK WASHER ZINC 1/2"
36	NC01-96-0014	2	NYLON-INSERT LOCKNUT ZINC 1/2-13
37	39-01-0130	4	BEARING GUARD
38	39-01-1051	1	HYDRAULIC HOSE SUPPORT
39	NC13-25-0019	3	NYLON CABLE TIE
40	39-57-0061	1	CHAIN GUARD
41	39-41-0000	1	ROLLER CHAIN GUARD CABLE
42	NC01-64-0005	2	OVAL SLEEVE (ALUMINUM)
43	NC02-22-0010	1	WASHER 13/32" ID
44	39-21-0075	1	WASHER FOR HYDRAULIC MOTOR
45	NC02-44-0090	2	SCREW PRESSURE 6 PANS 1/4-20 X 3/8 "LG

39-55-0160

#	PART #	Qty	TITLE
46	39-01-0030	1	CHAIN TENSIONER ARM
47	39-21-0070	1	CHAIN TENSIONER SHAFT
48	NC01-17-0119	1	HEX. BOLT GR2 ZINC 3/8-16 X 2 1/4"
49	21-01-0950	1	FLAT WASHER 10GA 1.005" DIA X 25/64"
50	NC02-32-0012	1	LOCK WASHER ZINC 3/8"
51	NC02-07-0018	1	HEX. NUT ZINC 3/8-16
52	39-55-0165	1	CHAIN TENSIONER SPROCKET ASSEMBLY

39-57-0109

#	PART #	Qty	TITLE
1	39-55-0265	1	FRONT-LEFT ROLLER
2	39-09-1205	1	BUSHING
3	39-42-0700	1	PIVOTING BLOCK
4	NC01-37-0480	1	HEX. BOLT GR8 ZINC 3/4-16 X 5 1/2"
5	NC02-32-0017	1	LOCK WASHER ZINC 3/4"
6	NC02-11-0023	1	NUT 3/4-16

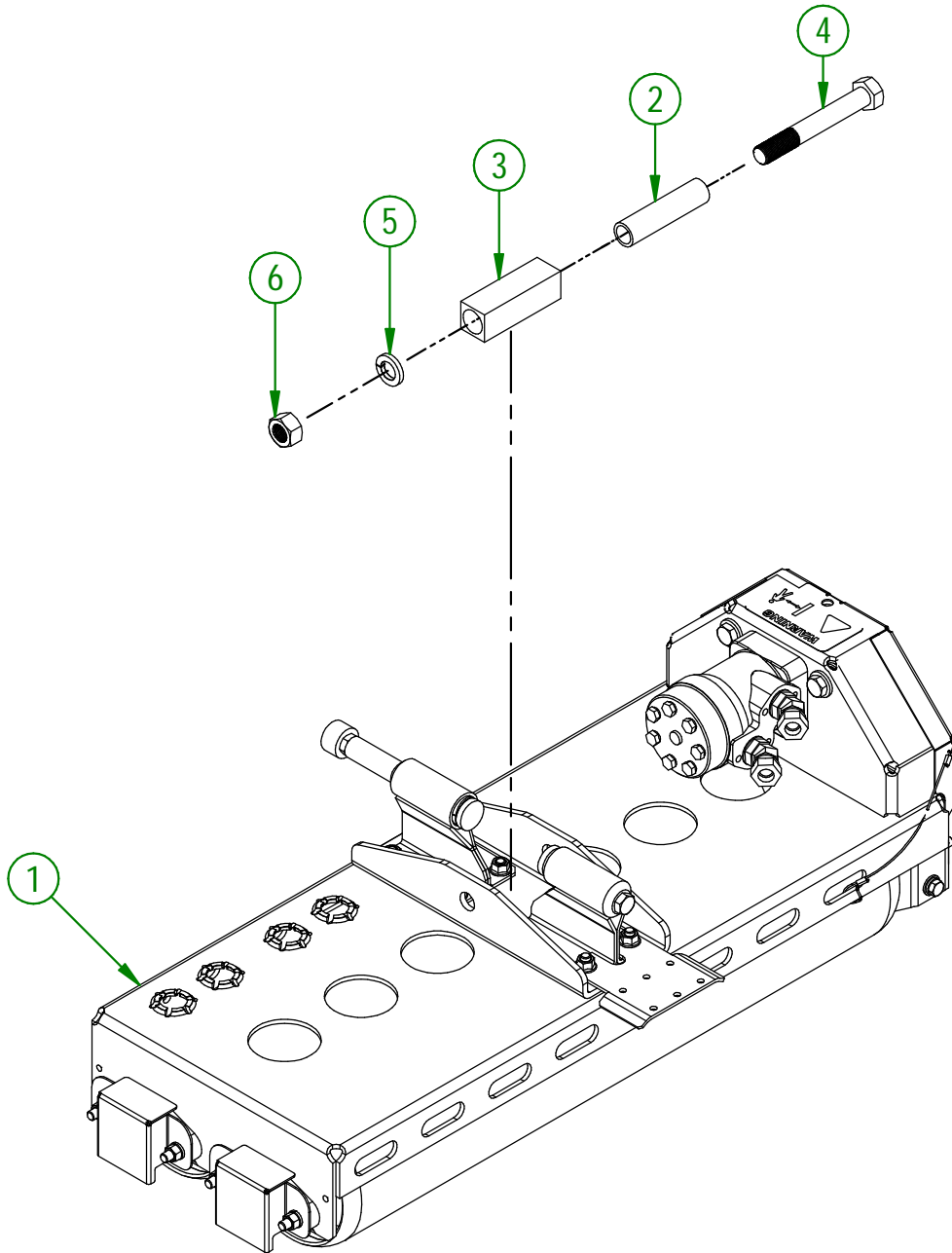

AGRIMETAL	
FRONT-LEFT ROLLER	
CREATION : 20/12/21	ASSEMBLY : 39-57-0109
REVISION : 20/12/21	AUTHOR : D. Bevins

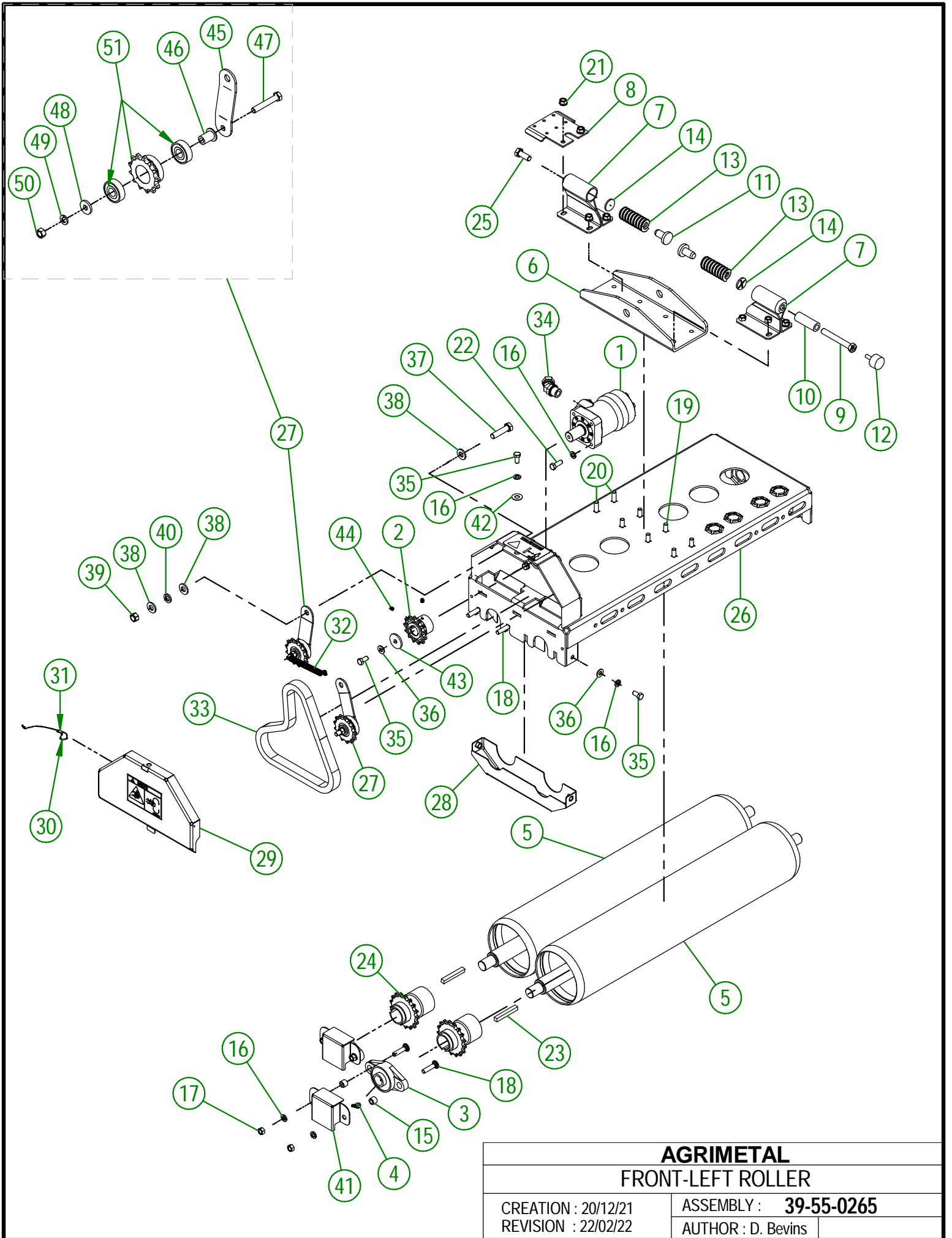

AGRIMETAL
FRONT-LEFT ROLLER

CREATION : 20/12/21
 REVISION : 22/02/22

ASSEMBLY : **39-55-0265**
 AUTHOR : D. Bevins

39-55-0265

#	PART #	Qty	TITLE
1	NC14-45-0040	1	50cc HYDRAULIC MOTOR
2	39-50-0057	1	HYDRAULIC MOTOR SPROCKET
3	NC14-75-0019	4	FLANGE PILLOW BLOCK BEARING UCFL205-16 Ø 1"
4	NC01-69-0802	4	GREASE FITTING 6mm X 45mm
5	39-50-0096	2	ROLLER (I KW)
6	39-04-0225	1	ROLLER SUPPORT
7	39-50-0045	2	SPRING GUIDE
8	39-01-1050	1	HYDRAULIC HOSE SUPPORT
9	39-30-9957	1	RAMP STOP SPACER
10	39-21-0032	1	RAMP STOP SPACER
11	39-42-0100	2	SPRING TIP
12	NC13-15-0034	1	RUBBER ABSORBER
13	NC13-86-0159	2	RED SPRING I 1/4"OD X 5/8"ID X 2" LG
14	39-01-1000	2	SPRING GUIDE WASHER
15	32-09-0000	4	BUSHING BEARING
16	NC02-32-0012	15	LOCK WASHER ZINC 3/8"
17	NC02-07-0018	8	HEX. NUT ZINC 3/8-16
18	NC01-04-0111	8	CARR. BOLT GR2 ZINC 3/8-16 X 1 1/2"
19	NC01-04-0109	6	CARR. BOLT GR2 ZINC 3/8-16 X 1"
20	NC01-04-0110	2	CARR. BOLT GR2 ZINC 3/8-16 X 1 1/4"
21	NC02-14-0019	8	FLANGE NUT HEX. NC 3/8-16 GR. B
22	NC01-17-0114	4	HEX. BOLT GR2 ZINC 3/8-16 X 1"
23	48-41-0905	2	SQUARE KEY 3/8" X 2 3/4" LG
24	39-50-0052	2	ROLLER SPROCKET
25	NC01-17-0248	1	HEX. BOLT GR2 ZINC 1/2-13 X 1 1/4"
26	39-57-0163	1	ROLLER HOUSING (FRONT-LEFT)
27	39-55-0160	2	CHAIN TENSIONER SPROCKET
28	39-50-0130	1	ROLLER CHAIN GUARD
29	39-57-0061	1	CHAIN GUARD
30	39-41-0000	1	ROLLER CHAIN GUARD CABLE
31	NC01-64-0005	2	OVAL SLEEVE (ALUMINUM)
32	NC13-85-0058	1	CHAIN TENSIONER SPRING
33	39-37-0000	1	CHAIN
34	NC13-45-0367	2	45°-7/8-14 MALE O RING X 1/2 FEM.TOUR.NPT PT
35	NC01-17-0112	4	HEX. BOLT GR2 ZINC 3/8-16 X 3/4"
36	01-01-2485	3	FLAT WASHER 14 GA X 13/16"OD X 25/64" ID
37	NC01-17-0251	2	HEX. BOLT GR2 ZINC 1/2-13 X 2"
38	NC02-25-0011	6	WASHER SAE ZINC 17/32 ID
39	NC01-96-0014	2	NYLON-INSERT LOCKNUT ZINC 1/2-13
40	NC02-32-0014	2	LOCK WASHER ZINC 1/2"
41	39-01-0130	4	BEARING GUARD
42	NC02-22-0010	1	WASHER 13/32" ID
43	39-21-0075	1	WASHER FOR HYDRAULIC MOTOR
44	NC02-44-0090	2	SCREW PRESSURE 6 PANS 1/4-20 X 3/8 "LG

39-55-0160

#	PART #	Qty	TITLE
45	39-01-0030	1	CHAIN TENSIONER ARM
46	39-21-0070	1	CHAIN TENSIONER SHAFT
47	NC01-17-0119	1	HEX. BOLT GR2 ZINC 3/8-16 X 2 1/4"
48	21-01-0950	1	FLAT WASHER 10GA 1.005" DIA X 25/64"
49	NC02-32-0012	1	LOCK WASHER ZINC 3/8"
50	NC02-07-0018	1	HEX. NUT ZINC 3/8-16
51	39-55-0165	1	CHAIN TENSIONER SPROCKET ASSEMBLY

39-57-0114

#	PART #	Qty	TITLE
1	39-55-0270	1	BACK-LEFT ROLLER
2	39-09-1205	1	BUSHING
3	39-42-0700	1	PIVOTING BLOCK
4	NC01-37-0480	1	HEX. BOLT GR8 ZINC 3/4-16 X 5 1/2"
5	NC02-32-0017	1	LOCK WASHER ZINC 3/4"
6	NC02-11-0023	1	NUT 3/4-16

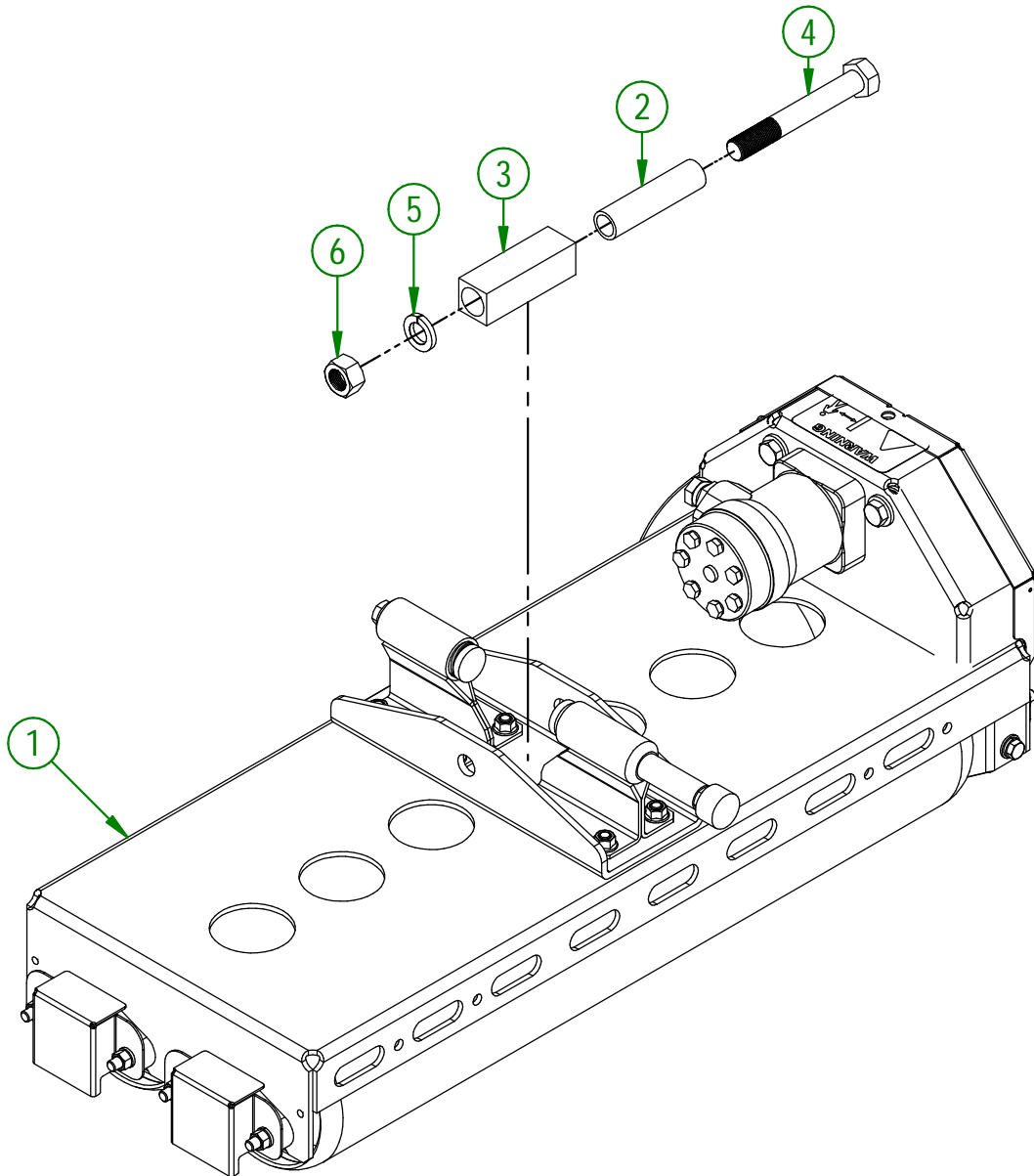

AGRIMETAL	
BACK-LEFT ROLLER	
CREATION : 20/12/21	ASSEMBLY : 39-57-0114
REVISION : 20/12/21	AUTHOR : D. Bevins

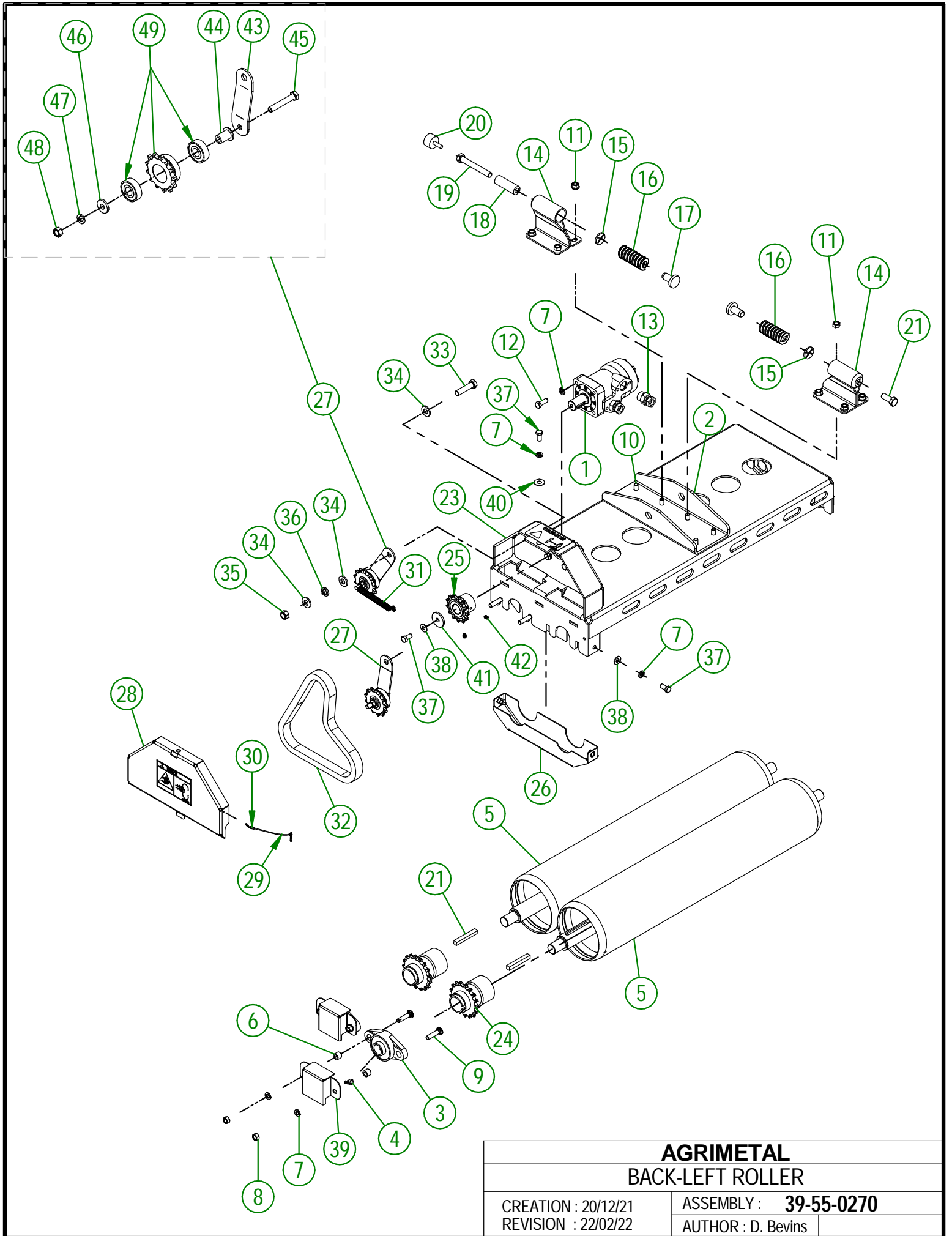

AGRIMETAL
BACK-LEFT ROLLER

CREATION : 20/12/21
 REVISION : 22/02/22

ASSEMBLY : **39-55-0270**
 AUTHOR : D. Bevins

39-55-0270

#	PART #	Qty	TITLE
1	NC14-45-0040	1	50cc HYDRAULIC MOTOR
2	39-04-0225	1	ROLLER SUPPORT
3	NC14-75-0019	4	FLANGE PILLOW BLOCK BEARING UCFL205-16 Ø 1"
4	NC01-69-0802	4	GREASE FITTING 6mm X 45mm
5	39-50-0096	2	ROLLER (1 KW)
6	32-09-0000	4	BUSHING BEARING
7	NC02-32-0012	15	LOCK WASHER ZINC 3/8"
8	NC02-07-0018	8	HEX. NUT ZINC 3/8-16
9	NC01-04-0111	8	CARR. BOLT GR2 ZINC 3/8-16 X 1 1/2"
10	NC01-04-0109	8	CARR. BOLT GR2 ZINC 3/8-16 X 1"
11	NC02-14-0019	8	FLANGE NUT HEX. NC 3/8-16 GR. B
12	NC01-17-0114	4	HEX. BOLT GR2 ZINC 3/8-16 X 1"
13	NC13-45-0073	2	STRAIGHT 7/8-14 MALE SAE10 O-RING X 3/8 FEM. TOUR. NPT
14	39-50-0045	2	SPRING GUIDE
15	39-01-1000	2	SPRING GUIDE WASHER
16	NC13-86-0159	2	RED SPRING 1 1/4"OD X 5/8"ID X 2" LG
17	39-42-0100	2	SPRING TIP
18	39-21-0032	1	RAMP STOP SPACER
19	39-30-9957	1	RAMP STOP SPACER
20	NC13-15-0034	1	RUBBER ABSORBER
21	NC01-17-0248	1	HEX. BOLT GR2 ZINC 1/2-13 X 1 1/4"
22	48-41-0905	2	SQUARE KEY 3/8" X 2 3/4" LG
23	39-57-0167	1	ROLLER HOUSING (BACK-LEFT)
24	39-50-0052	2	ROLLER SPROCKET
25	39-50-0057	1	HYDRAULIC MOTOR SPROCKET
26	39-50-0130	1	ROLLER CHAIN GUARD
27	39-55-0160	2	CHAIN TENSIONER SPROCKET
28	39-57-0061	1	CHAIN GUARD
29	39-41-0000	1	ROLLER CHAIN GUARD CABLE
30	NC01-64-0005	2	OVAL SLEEVE (ALUMINUM)
31	NC13-85-0058	1	CHAIN TENSIONER SPRING
32	39-37-0000	1	CHAIN
33	NC01-17-0251	2	HEX. BOLT GR2 ZINC 1/2-13 X 2"
34	NC02-25-0011	6	WASHER SAE ZINC 17/32 ID
35	NC01-96-0014	2	NYLON-INSERT LOCKNUT ZINC 1/2-13
36	NC02-32-0014	2	LOCK WASHER ZINC 1/2"
37	NC01-17-0112	4	HEX. BOLT GR2 ZINC 3/8-16 X 3/4"
38	01-01-2485	3	FLAT WASHER 14 GA X 13/16"OD X 25/64" ID
39	39-01-0130	4	BEARING GUARD
40	NC02-22-0010	1	WASHER 13/32" ID
41	39-21-0075	1	WASHER FOR HYDRAULIC MOTOR
42	NC02-44-0090	2	SCREW PRESSURE 6 PANS 1/4-20 X 3/8 "LG

39-55-0160

#	PART #	Qty	TITLE
43	39-01-0030	1	CHAIN TENSIONER ARM
44	39-21-0070	1	CHAIN TENSIONER SHAFT
45	NC01-17-0119	1	HEX. BOLT GR2 ZINC 3/8-16 X 2 1/4"
46	21-01-0950	1	FLAT WASHER 10GA 1.005" DIA X 25/64"
47	NC02-32-0012	1	LOCK WASHER ZINC 3/8"
48	NC02-07-0018	1	HEX. NUT ZINC 3/8-16
49	39-55-0165	1	CHAIN TENSIONER SPROCKET ASSEMBLY

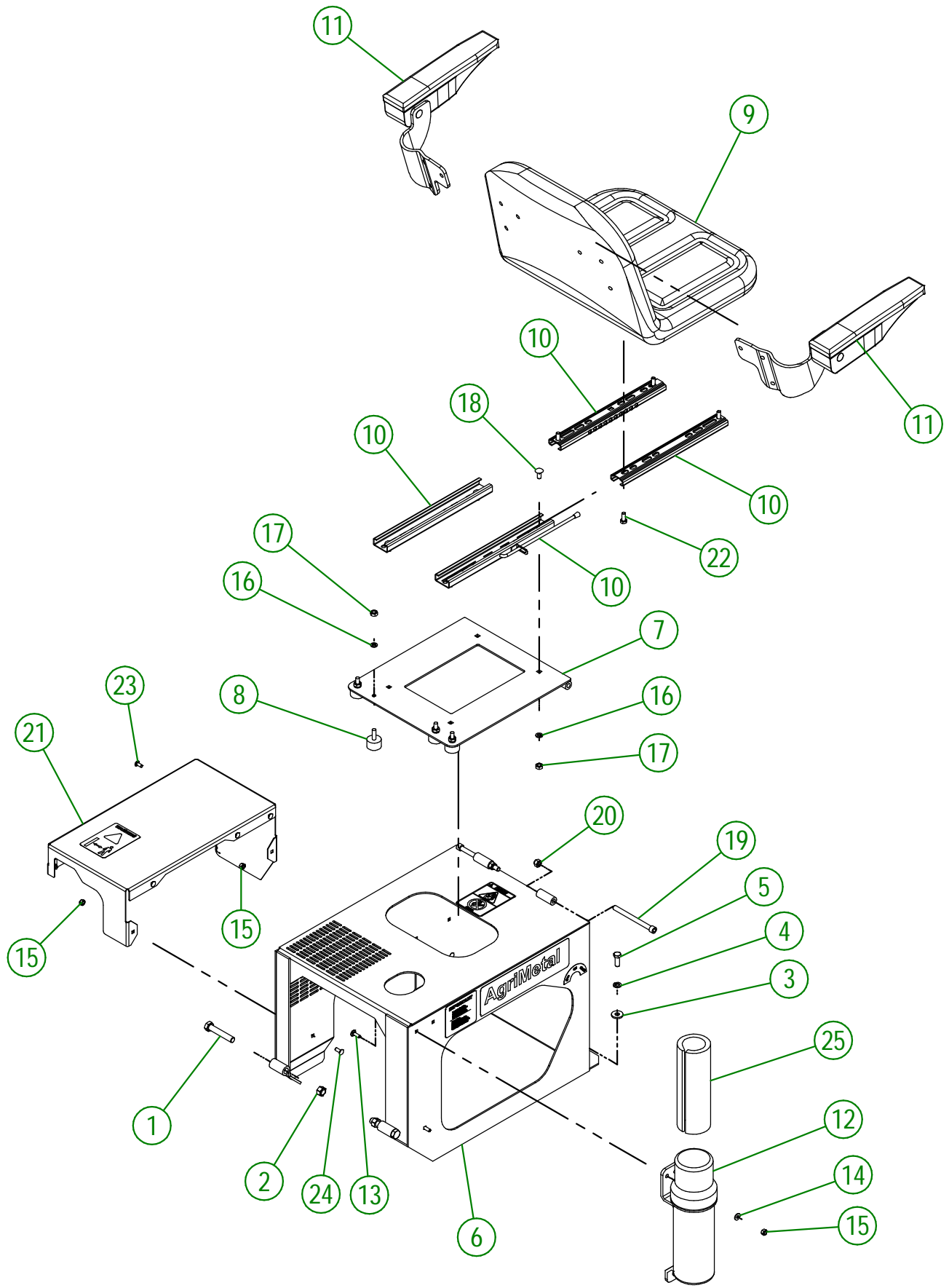

USE THESE PIECES ONLY IF YOUR SERIAL NUMBER IS AFFECTED:

#39530 AND ABOVE

AGRIMETAL	
ENGINE COVER GROUP	
CREATION : 09/02/22	ASSEMBLY : 39-57-0043
REVISION : 09/02/22	AUTHOR : J. Houle

39-57-0043

#	PART #	Qty	TITLE
1	NC01-17-0254	2	HEX. BOLT GR2 ZINC 1/2-13 X 2 1/2"
2	NC01-96-0014	2	NYLON-INSERT LOCKNUT ZINC 1/2-13
3	21-01-0950	2	FLAT WASHER IOGA 1.005" DIA X 25/64"
4	NC02-32-0012	2	LOCK WASHER ZINC 3/8"
5	NC01-17-0114	2	HEX. BOLT GR2 ZINC 3/8-16 X 1"
6	39-57-0010	1	ENGINE COVER
7	39-50-0115	1	SEAT FOLDER HOLDER
8	NC13-15-0034	4	RUBBER ABSORBER
9	NC13-80-0200	1	SEAT
10	NC13-80-0201	1	SET OF SEAT RAIL
11	NC13-80-0295	1	ARMRESTS
12	NC13-30-0237	1	PLASTIC TUBE FOR OPERATOR'S MANUAL
13	NC01-04-0003	3	CARR. BOLT GR2 ZINC 1/4-20 X 3/4"
14	NC02-25-0007	3	WASHER ZINC 0.281 = 9/32
15	NC01-96-0009	11	NYLON-INSERT LOCKNUT ZINC 1/4-20
16	NC02-32-0011	8	LOCK WASHER ZINC 5/16"
17	NC02-07-0017	8	HEX. NUT 5/16-18
18	NC01-04-0056	4	CARR. BOLT 5/16-18 X3/4"
19	NC02-50-0112	2	HEX. BOLT GR2 ZINC 3/8-16 X 4 1/2"
20	NC01-96-0011	2	NYLON NUT 3/8-16
21	39-57-0536	1	HYDROSTATIC POMP GUARD GROUP (STICKER INCLUDED)
22	NC01-17-0058	4	HEX. BOLT GR2 ZINC 5/16-18 X 3/4"
23	NC01-04-0001	3	CARR. BOLT GR2 ZINC 1/4-20 X1/2"
24	NC01-04-0002	5	CARR. BOLT GR2 ZINC 1/4-20 X 5/8"
25	39-98-0621	1	660 OPERATOR'S MANUAL

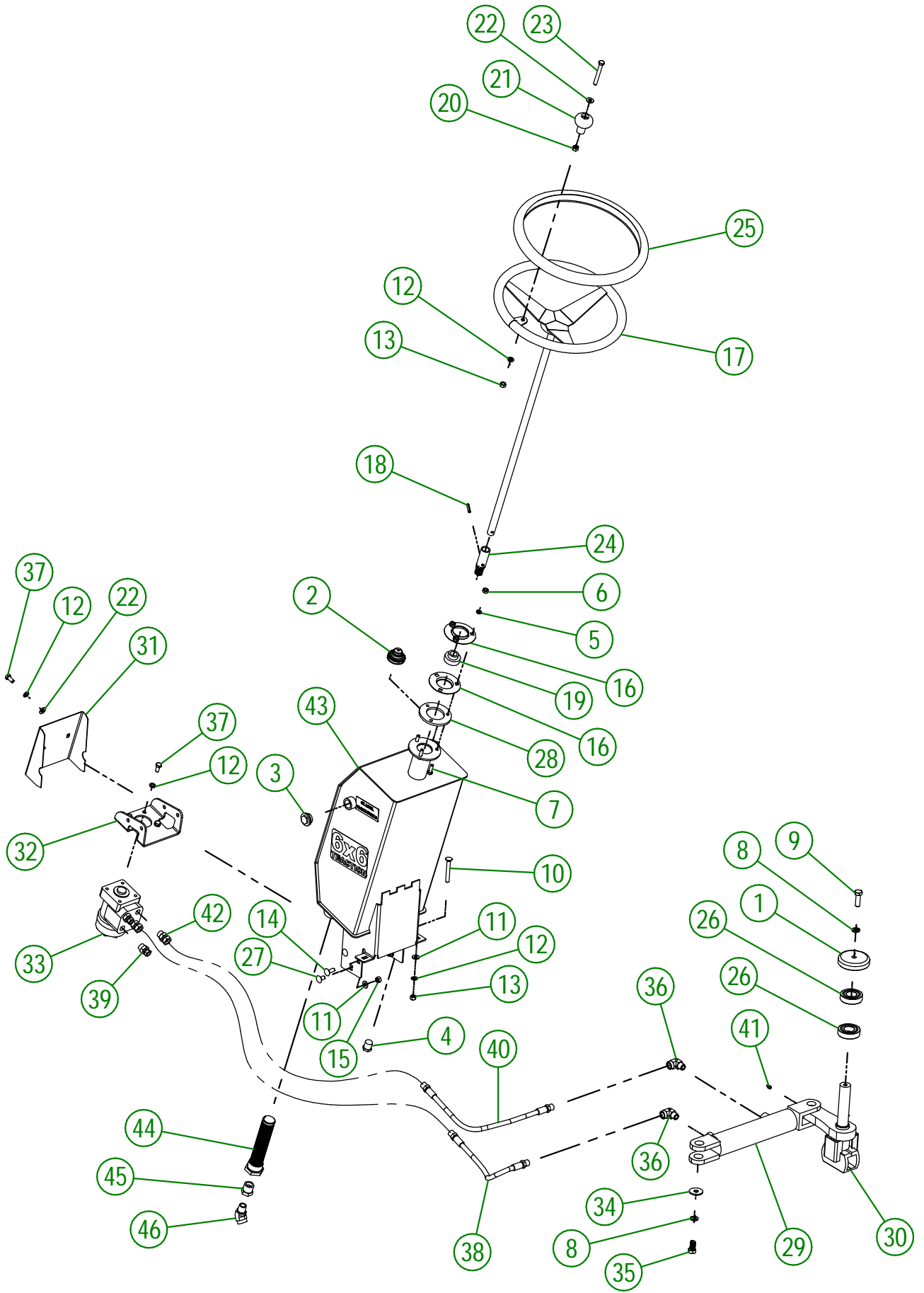

AGRIMETAL	
STEERING SYSTEM GROUP	
CREATION : 21/12/21	ASSEMBLY : 39-57-0047
REVISION : 21/12/21	AUTHOR : D. Bevins

39-57-0047

#	PART #	Qty	TITLE
1	39-21-0000	1	STEERING PLATE SHAFT COVER
2	NC13-37-0121	1	TANK CAP
3	NC01-76-0001	1	SIGHT GLASS 3/4 NPT
4	NC13-45-0015	1	HEX. CAP 1/2 NPTF MALE
5	NC02-32-0011	3	LOCK WASHER ZINC 5/16"
6	NC02-07-0017	3	HEX. NUT 5/16-18
7	NC01-17-0060	3	HEX. BOLT GR2 ZINC 5/16-18 X 1"
8	NC02-32-0014	2	LOCK WASHER ZINC 1/2"
9	NC01-17-0249	1	HEX. BOLT GR2 ZINC 1/2-13 X 1 1/2"
10	NC01-04-0116	2	CARR. BOLT GR2 ZINC 3/8-16 X 2 3/4"
11	01-01-2485	8	FLAT WASHER 14 GA X 13/16"OD X 25/64" ID
12	NC02-32-0012	9	LOCK WASHER ZINC 3/8"
13	NC02-07-0018	3	HEX. NUT ZINC 3/8-16
14	NC01-04-0109	4	CARR. BOLT GR2 ZINC 3/8-16 X 1"
15	NC01-93-0011	6	LOCK NUT 3/8-16
16	NC14-75-0008	2	STEEL BEARING ONLY 3 HOLES F4 3 9/16" OD
17	39-50-0081	1	STEERING WHEEL
18	NC01-69-0459	1	ZINC SPRING PIN TENDER DIA. 1/4" X 1 1/4"
19	NC14-75-0014	1	STEEL BEARING SB 204-12 X 3/4" ID
20	NC01-96-0011	1	NYLON NUT 3/8-16
21	NC17-46-0018	1	HANDLE KNOB
22	NC17-57-0016	3	FLAT WASHER 14 GA X 13/16"OD X 25/64" ID
23	NC01-17-0122	1	HEX. BOLT GR2 ZINC 3/8-16 X 3"
24	39-20-0005	1	STEERING SHAFT ADAPTER
25	NC13-80-0254	1	STEERING WHEEL COVER
26	NC14-75-0091	2	6206 ZZ BEARING
27	NC01-04-0107	2	CARR. BOLT GR2 ZINC 3/8-16 X 3/4"
28	39-04-0275	1	STEERING SHAFT BEARING SUPPORT
29	NC13-45-0370	1	HYDRAULIC CYLINDER 6"
30	39-50-0071	1	STEERING PLATE
31	39-01-0080	1	STEERING SHAFT GUARD
32	39-04-0195	1	HYDRAULIQUE CONTROL SUPPORT
33	NC14-45-0151	1	HYDRAULIC STEERING ASSIST
34	01-01-1660	1	WASHER SPACER
35	NC01-17-0247	1	HEX. BOLT GR2 ZINC 1/2-13 X 1"
36	NC13-45-0038	2	ELBOW 90 3/8 FEM. NPT X 3/8 MALE NPT
37	NC01-17-0112	6	HEX. BOLT GR2 ZINC 3/8-16 X 3/4"
38	NC17-02-0418	1	HYD. HOSE 1/4 X 16 1/2"OAL 3/8 NPTMALE RIG.X 3/8NPTMALE RIG
39	NC13-45-0204	2	STRAIGHT REDUCER 3/4-16 MALE SAE8 O RING X 1/4 FEMALE
40	NC17-02-0419	1	HYD. HOSE 1/4 X 17"OAL 3/8 NPTMALE RIG.X 3/8NPTMALE RIG
41	NC01-69-0785	1	STRAIGHT GREASE FITTING 1/4-28
42	NC13-45-0036	2	STRAIGHT REDUCER 3/4-16 MALE SAE8 O RING X 1/4 FEMALE
43	39-57-0007	1	OIL TANK
44	NC13-45-0381	1	TANK STRAINER
45	NC13-45-0032	1	STRAIGHT HOSE FITTING 1/2 FEM. NPT X 3/4 MALE NPT
46	NC13-45-0086	1	ELBOW 45 1/2 FEM. NPT X 1/2 MALE NPT

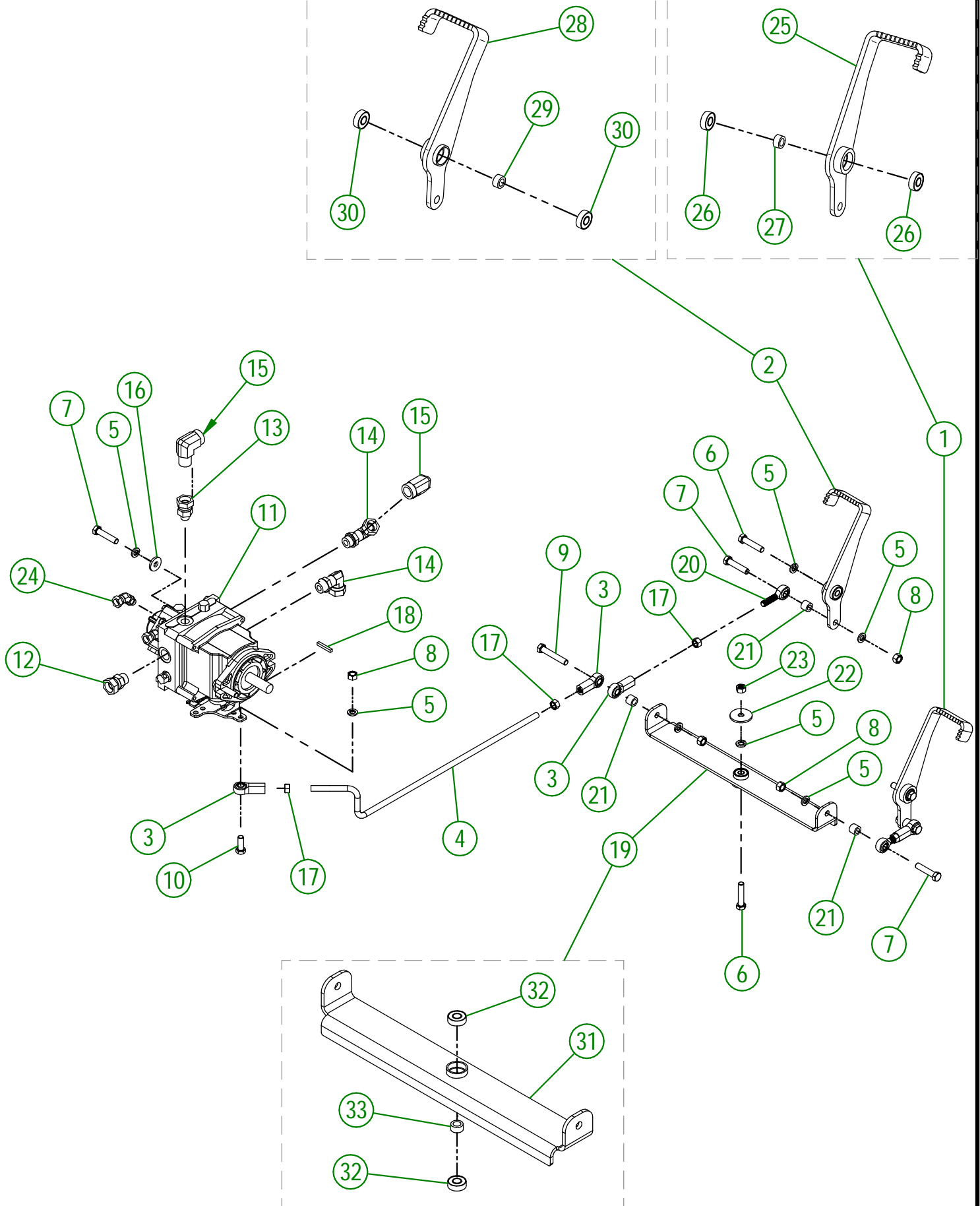

AGRIMETAL	
HYDROSTATIC SYSTEM GROUP	
CREATION : 21/12/21	ASSEMBLY : 39-57-0200
REVISION : 21/12/21	AUTHOR : J. Houle

39-57-0200

#	PART #	Qty	TITLE
1	39-55-0026	1	RIGHT PEDAL
2	39-55-0021	1	LEFT PEDAL
3	NC01-67-0104	4	INTERNALLY THREADED BALL JOINT ROD ENDS 3/8-24
4	39-13-0401	1	HYDROSTATIC CONTROL ROD
5	NC02-32-0012	10	LOCK WASHER ZINC 3/8"
6	NC01-33-0117	3	CARR. BOLT GR8 ZINC 3/8-16 X 1 3/4"
7	NC01-17-0117	5	HEX. BOLT GR2 ZINC 3/8-16 X 1 3/4"
8	NC02-07-0018	5	HEX. NUT ZINC 3/8-16
9	NC01-17-0119	1	HEX. BOLT GR2 ZINC 3/8-16 X 2 1/4"
10	NC01-17-0114	1	HEX. BOLT GR2 ZINC 3/8-16 X 1"
11	39-55-0036	1	HYDRAUSTATIC MOTOR HYDRO-GEAR PRE-ASSEM.
12	NC13-45-0106	1	STRAIGHT REDUCER 3/4-16 MALE SAE8 O RING X 1/2 FEMALE
13	NC13-45-0220	1	STRAIGHT 9/16 MALE ORING X 1/2 FEMALE NPT
14	NC13-45-0203	2	ELBOW 90° 3/4 MALE ORING X 1/2 FEMALE NPT
15	NC13-45-0025	2	ELBOW 90° 1/2 FEMALE NPT X 1/2 MALE NPT
16	21-01-0950	2	FLAT WASHER 10GA 1.005" DIA X 25/64"
17	NC02-10-0018	4	NUT 3/8-24
18	01-41-0905	1	SQUARE KEY 3/16" X 1 1/4"TL
19	39-55-0046	1	PEDAL JUNCTION ARM
20	NC01-67-0304	2	BALL JOINTS ROD ENDS 3/8-24
21	01-09-0000	4	BEARING RACE (UCFL205-16)
22	01-33-0010	1	WASHER
23	NC01-93-0011	1	LOCK NUT 3/8-16
24	NC13-45-0372	2	FITTING 45° 7/16-20 MALE O RING SAE4 X 1/4 FEM. TOURNPT

39-55-0026

#	PART #	Qty	TITLE
25	39-50-0106	1	RIGHT PEDAL
26	NC14-75-0153	2	BALL BEARING R6 2RS 3/8" X 7/8" X 0.281"
27	01-09-0005	1	BUSHING

39-55-0021

#	PART #	Qty	TITLE
28	39-50-0111	1	LEFT PEDAL
29	01-09-0005	1	BUSHING
30	NC14-75-0153	2	BALL BEARING R6 2RS 3/8" X 7/8" X 0.281"

39-55-0046

#	PART #	Qty	TITLE
31	39-50-0041	1	
32	NC14-75-0153	2	BALL BEARING R6 2RS 3/8" X 7/8" X 0.281"
33	01-09-0005	1	BUSHING

#	PART #	Qty	TITLE
1	26-03-4800	4	WASHER
2	NC13-15-0068	2	GREEN RUBBER BASE MOUNT
3	NC13-15-0059	2	YELLOW RUBBER BASE MOUNT
4	01-33-0010	8	WASHER
5	NC01-17-0123	4	HEX. BOLT GR2 ZINC 3/8-16
6	01-01-2485	4	FLAT WASHER 14 GA X 13/16"OD X 25/64" ID
7	NC02-32-0012	4	LOCK WASHER ZINC 3/8"
8	NC02-07-0018	4	HEX. NUT ZINC 3/8-16
9	NC14-05-0029	1	COUPLING (LOVEJOY) CXL100 X 1" ID
10	NC14-05-0030	1	COUPLING (LOVEJOY) RUBBER N100
11	39-46-3500	1	HYDROSTATIC COUPLING HUB

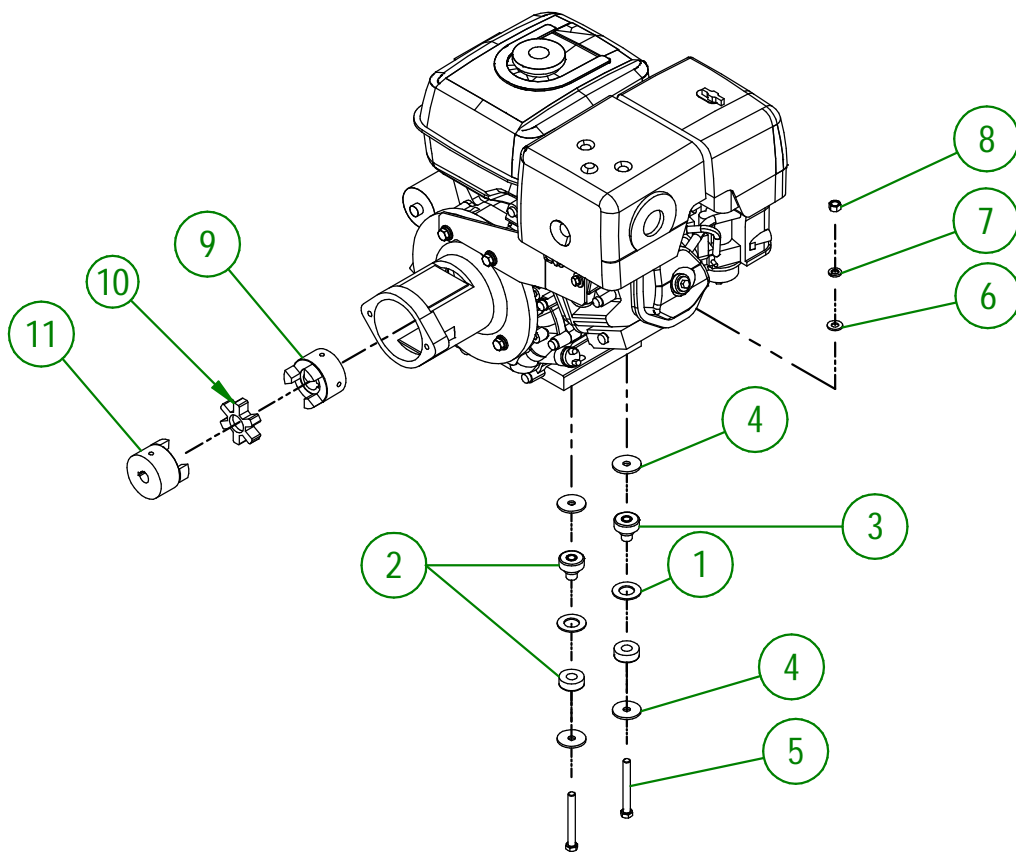

AGRIMETAL	
MOTOR GROUP	
CREATION : 21/12/21	ASSEMBLY : 39-57-0116
REVISION : 21/12/21	AUTHOR : Dessin1

#	PART #	Qty	TITLE
1	39-01-1090	1	MUFFLER SUPPORT
2	39-50-0120	1	FUEL ENGINE ADAPTER FOR HYDROSTATIC PUMP
3	39-01-1080	1	MUFFLER SUPPORT
4	39-50-0085	1	MUFFLER SUPPORT
5	01-01-2485	4	FLAT WASHER 14 GA X 13/16"OD X 25/64" ID
6	NC02-32-0012	4	LOCK WASHER ZINC 3/8"
7	NC01-17-0115	2	HEX. BOLT GR2 ZINC 3/8-16 X 1 1/4"
8	NC01-17-0116	2	HEX. BOLT GR2 ZINC 3/8-16 X 1 1/2"
9	36-01-2430	2	WASHER
10	NC02-32-0010	2	LOCK WASHER ZINC 1/4"
11	NC01-37-0014	2	HEX. BOLT GR8 ZINC 1/4-28 X 3"

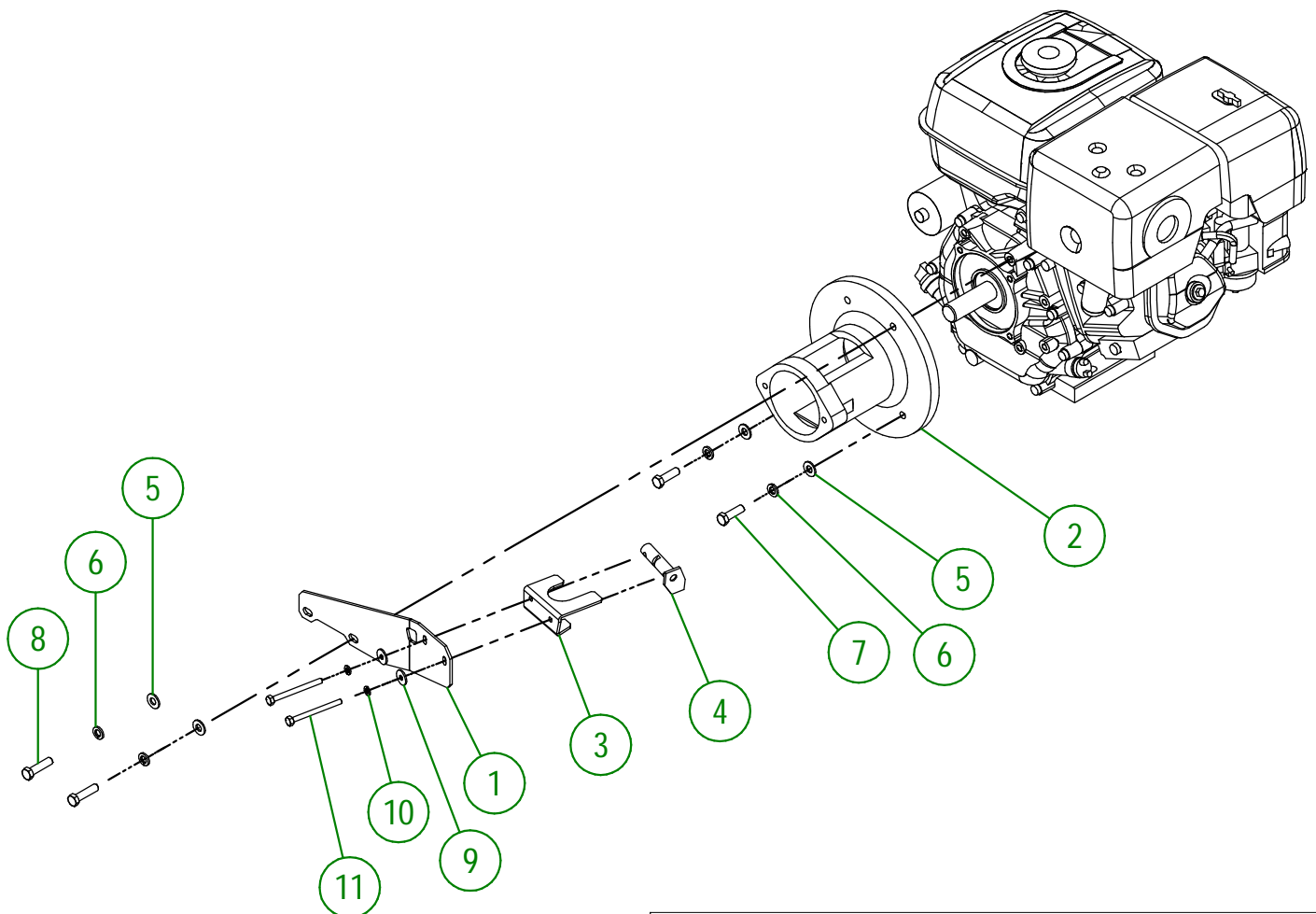
**AGRIMETAL****HONDA MOTOR WITH STARTER**

CREATION : 21/12/21
 REVISION : 21/12/21

ASSEMBLY : **39-55-0031**
 AUTHOR : Dessin1

#	PART #	Qty	TITLE
1	NCI3-12-0001	1	12 VOLTS BATTERY
2	39-57-0195	1	BATTERY STRAPE
3	39-01-3050	1	LIGHT SWITCH HOLDER
4	NCI3-25-0368	1	LIGHT SWITCH
5	NC01-04-0027	2	CARR. BOLT 1/4-20 X 6" LG
6	NC01-96-0009	2	NYLON-INSERT LOCKNUT ZINC 1/4-20
7	39-57-0016	1	COMPLETE ELECTRIC WIRE SET
8	39-55-0105	1	NEGATIVE BATTERY CABLE
9	39-55-0100	1	POSITIVE BATTERY CABLE
10	NCI3-25-0019	1	NYLON CABLE TIE
11	NCI3-80-0268	1	BLACK PROTECTOR FOR BATTERY POST
12	NCI3-80-0267	1	RED PROTECTOR FOR BATTERY POST
13	39-55-0121	2	LED LIGHT
14	39-21-0065	1	RIGHT LIGHT HOLDER
15	NC01-17-0068	1	HEX. BOLT GR2 NC ZINC 5/16-18 X 3"
16	01-01-2485	3	FLAT WASHER 14 GA X 13/16"OD X 25/64" ID
17	NC02-32-0011	1	LOCK WASHER ZINC 5/16"
18	NC02-07-0017	1	HEX. NUT 5/16-18
19	33-01-4000	1	HOUR METER HOLDER
20	NCI3-37-0669	1	HOUR METER

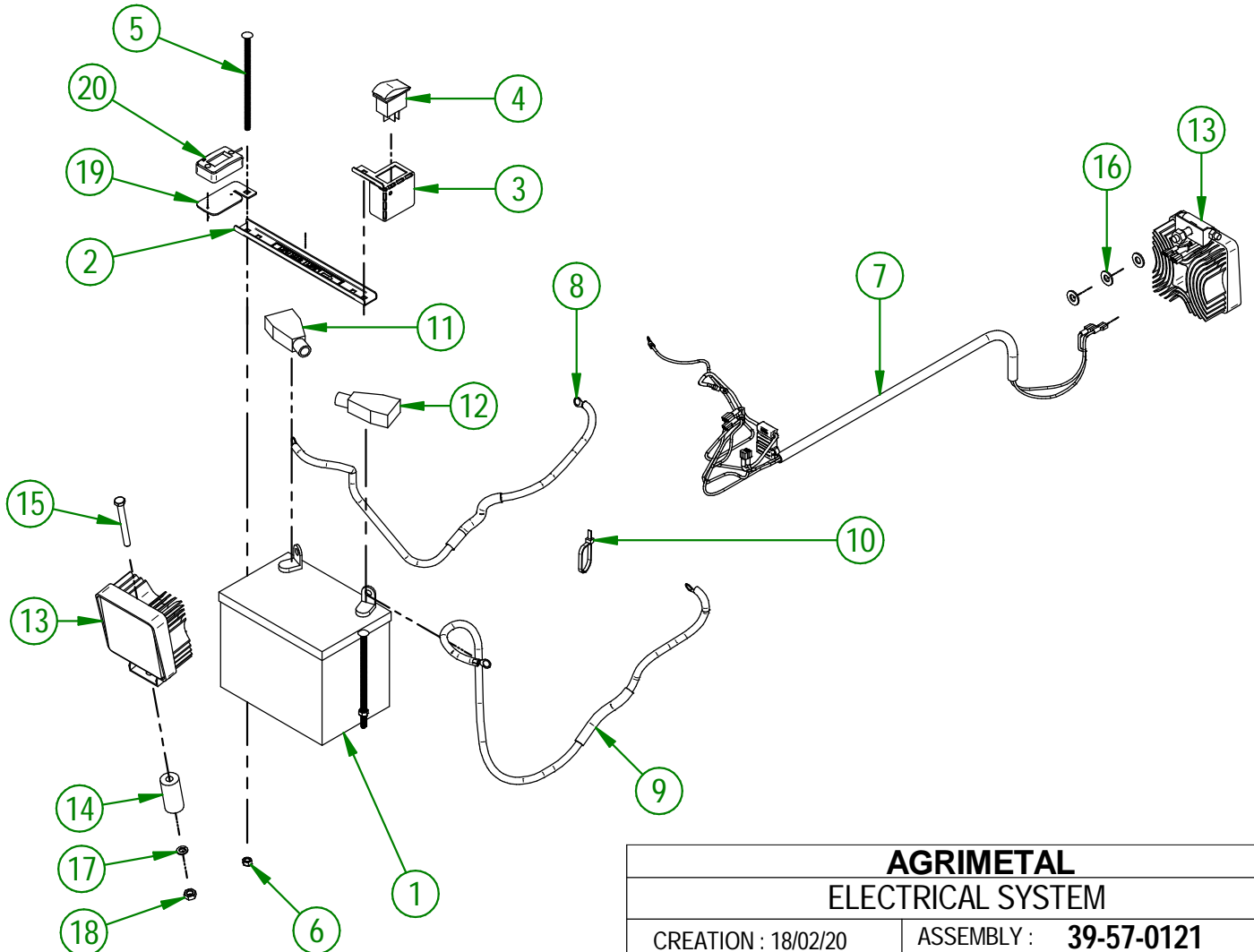

AGRIMETAL	
ELECTRICAL SYSTEM	
CREATION : 18/02/20	ASSEMBLY : 39-57-0121
REVISION : 17/02/22	AUTHOR : D. Bevins

#	PART #	Qty	TITLE
1*	NC13-40-0030	1	URETHANE HOSE
2*	39-57-0031	1	BROWN WIRE COMBINATION
3*	39-57-0025	1	WHITE WIRE COMBINATION
4*	39-57-0020	1	FUSE COMPARTMENT

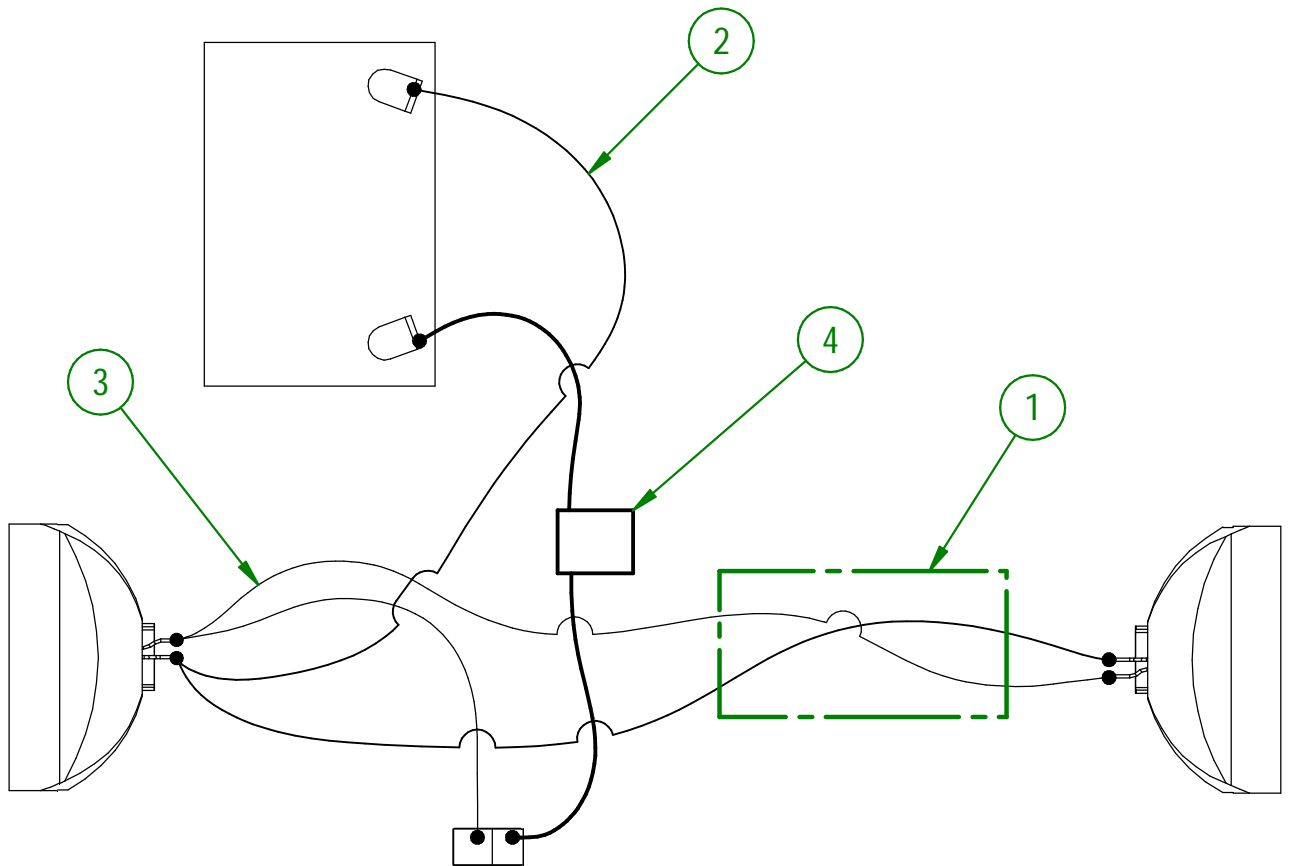

AGRIMETAL	
COMPLETE ELECTRIC WIRE SET	
CREATION : 21/12/21	ASSEMBLY : 39-57-0016
REVISION : 21/12/21	AUTHOR : Dessin1

#	PART #	Qty	TITLE
1	NCI3-45-0032	2	STRAIGHT HOSE FITTING 1/2 FEM. NPT X 3/4 MALE NPT
2	NCI3-45-0091	2	STRAIGHT HOSE FITTING 1/2 MALE NPTF X 1/2 FEM. SWIVEL
3	NCI7-02-0313	1	HYDRAULIC HOSE 19"
4	NCI7-02-0312	1	HYDRAULIC HOSE 48 1/2"
5	NCI7-02-0312	1	HYDRAULIC HOSE 48 1/2"
6	NCI7-02-0317	1	HYDRAULIC HOSE 64"
7	NCI7-02-0311	1	HYDRAULIC HOSE 17"
8	NCI7-02-0408	1	HYDRAULIC HOSE 14"
9	NCI3-40-0025	1	BLACK GASOLINE HOSE
10	NCI3-25-0019	9	NYLON CABLE TIE
11	39-55-0365	1	HYDRAULIC HOSE 75"
12	NCI7-02-0315	1	HYDRAULIC HOSE 60"
13	NCI7-02-0314	1	HYDRAULIC HOSE 44"
14	NCI7-02-0316	1	HYDRAULIC HOSE 66"
15	NCI3-45-0048	1	OIL FILTER
16	NCI3-45-0049	1	HEAD FILTER
17	NCI7-02-0420	1	HYD. HOSE 1/4 X 70"OAL 1/4 NPTMALE RIG.X 1/4NPTMALE RIG
18	NCI7-02-0420	1	HYD. HOSE 1/4 X 70"OAL 1/4 NPTMALE RIG.X 1/4NPTMALE RIG

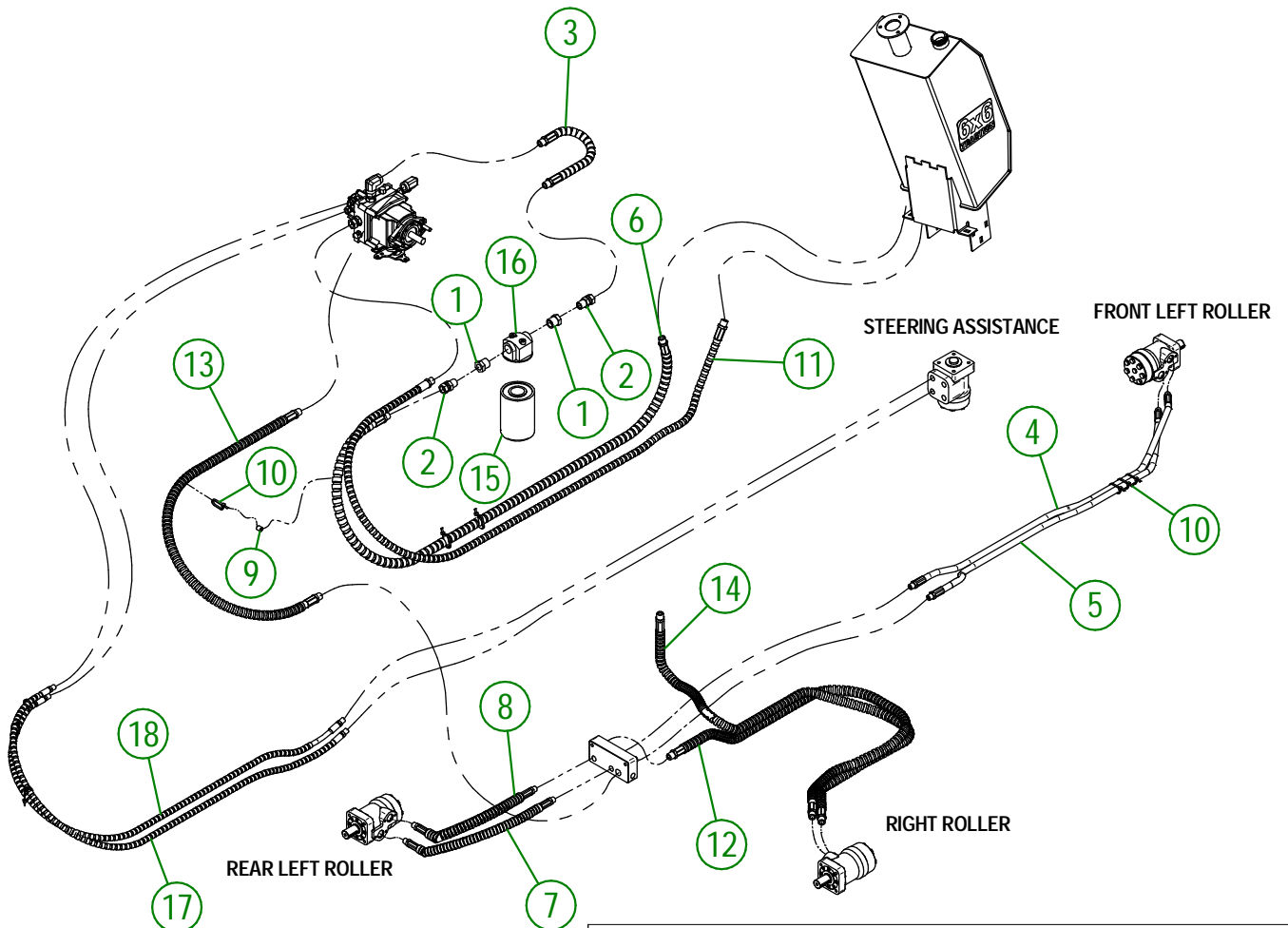

AGRIMETAL
HYDRAULIC SYSTEM

CREATION : 21/12/21
REVISION : 22/12/21

ASSEMBLY : **39-57-0205**
AUTHOR : D. Bevins

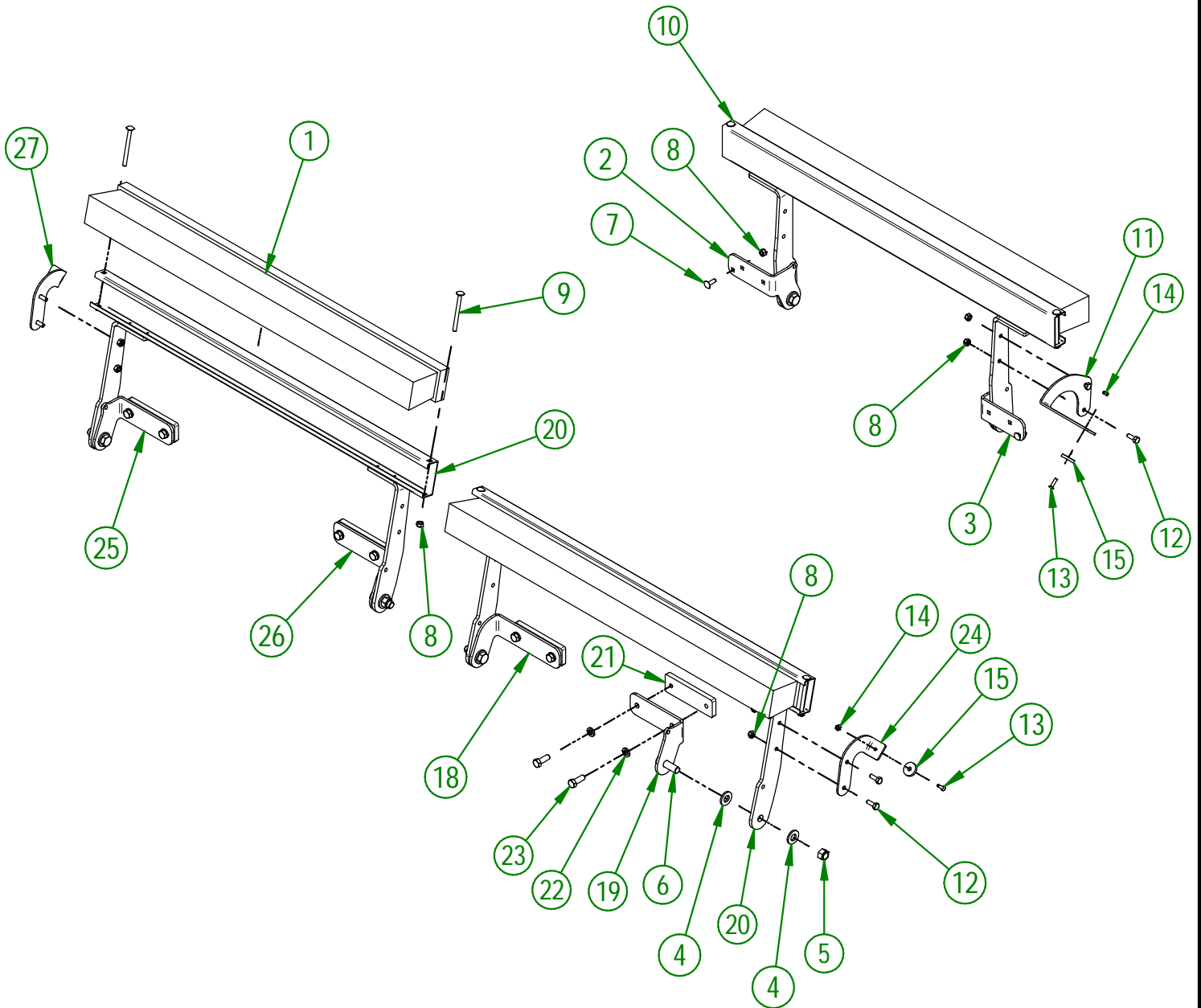

AGRIMETAL	
BRUSH OPTION	
CREATION : 25/05/21	ASSEMBLY : 39-57-9015
REVISION : 22/12/21	AUTHOR : G.HUBERDEAU

#	PART #	Qty	TITLE
1	NC13-80-0293	3	BRUSH
2	39-04-0505	1	RIGHT BRUSH HOLDER
3	39-04-0510	1	RIGHT BRUSH HOLDER
4	NC02-25-0011	18	WASHER SAE ZINC 17/32 ID
5	NC01-96-0014	6	NYLON-INSERT LOCKNUT ZINC 1/2-13
6	NC01-17-0249	6	HEX. BOLT GR2 ZINC 1/2-13 X 1 1/2"
7	NC01-04-0003	2	CARR. BOLT GR2 ZINC 1/4-20 X 3/4"
8	NC01-96-0009	14	NYLON-INSERT LOCKNUT ZINC 1/4-20
9	NC01-02-0013	6	CARR. BOLT GR2 ZINC 1/4-20 X 3/4"
10	39-50-9000	1	RIGHT BRUSH HOLDER
11	39-01-0295	1	MAGNET HOLDER (RIGHT)
12	NC01-17-0004	6	HEX. BOLT GR2 ZINC 1/4-20 X 3/4"
13	NC02-36-0110	3	MACHINE SCREW FLAT HEAD 10-24 X 3/4" LG.
14	NC01-96-0006	3	NYLON NUT ZINC 10-24
15	NC13-05-0008	3	MAGNET
16*	39-01-0240	1	JIG FOR LEFT BRUSHES
17*	39-01-0245	1	JIG FOR RIGHT BRUSH
18	39-04-0503	1	LEFT REAR BRUSH HOLDER
19	39-04-0500	1	LEFT REAR BRUSH HOLDER
20	39-50-9005	2	LEFT BRUSH HOLDER
21	39-05-0505	4	PLATE FOR BRUSH HOLDER
22	NC02-32-0012	8	LOCK WASHER ZINC 3/8"
23	NC01-17-0114	8	HEX. BOLT GR2 ZINC 3/8-16 X 1"
24	39-01-0290	1	MAGNET HOLDER (REAR-RIGHT)
25	39-04-0501	1	LEFT FRONT BRUSH HOLDER
26	39-04-0504	1	LEFT FRONT BRUSH HOLDER
27	39-01-0293	1	MAGNET HOLDER (REAR-LEFT)

AGRIMETAL
BRUSH OPTION

CREATION : 25/05/21
REVISION : 22/12/21

ASSEMBLY : **39-57-9015**
AUTHOR : G.HUBERDEAU

#	PART #	Qty	TITLE
1	NCI3-33-0232	1	STICKER AGRIMETAL GREENS ROLLER 660
2	NCI3-33-0003	1	STICKER OIL LEVEL
3	NCI3-33-0183	1	STICKER CAUTION OPERATION MANUAL
4	NCI3-33-0336	2	STICKER 6X6
5	NCI3-33-0340	1	STICKER 85 DB
6	NCI3-33-0185	1	STICKER PICTOGRAM (FIRE + CIGARETTE)
7	NCI3-33-0035	2	STICKER AGRIMETAL
8	NCI3-33-0095	1	STICKER OFF ON START
9	NCI3-33-0151	1	STICKER (IMPORTANT TO PREVENT ENGINE FAILURE...)
10	NCI3-33-0257	1	STICKER HIGH PRESSURE LIQUID PICTOGRAM
11	NCI3-33-0288	3	STICKER WARNING HIGH-PRESSURE LIQUID
12	NCI3-33-0247	3	STICKER DANGER
13	NCI3-33-0350	1	LIGHT SWITCH STICKER
14	NCI3-33-0124	2	STICKER STEERING ARROW

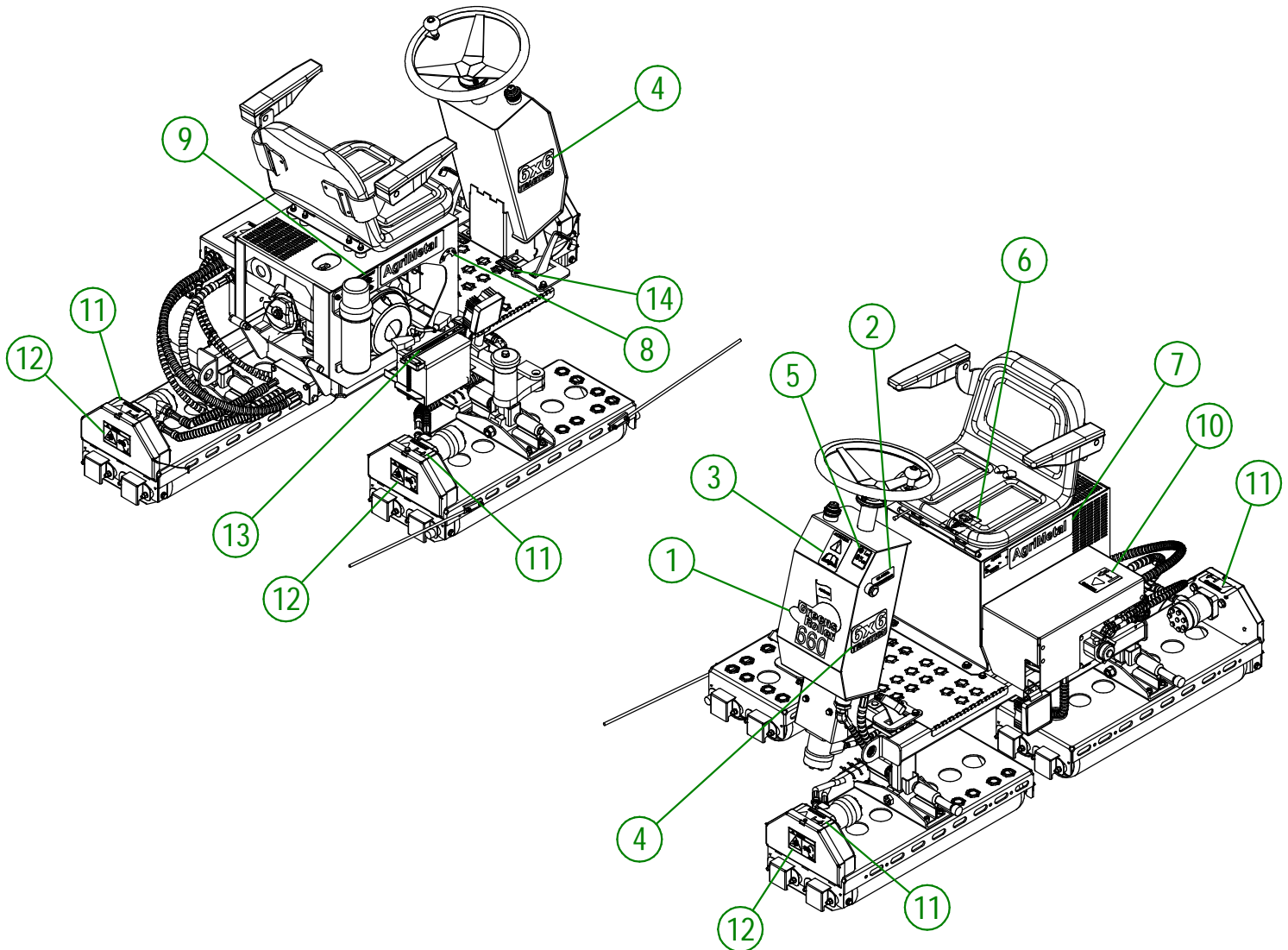

AGRIMETAL
GREEN ROLLER GR-660-F

CREATION : 22/12/21
REVISION : 22/12/21

ASSEMBLY : **39-99-0009**
AUTHOR : D. Bevins