

SP160EB

Electric Bunker Rake

Parts catalog

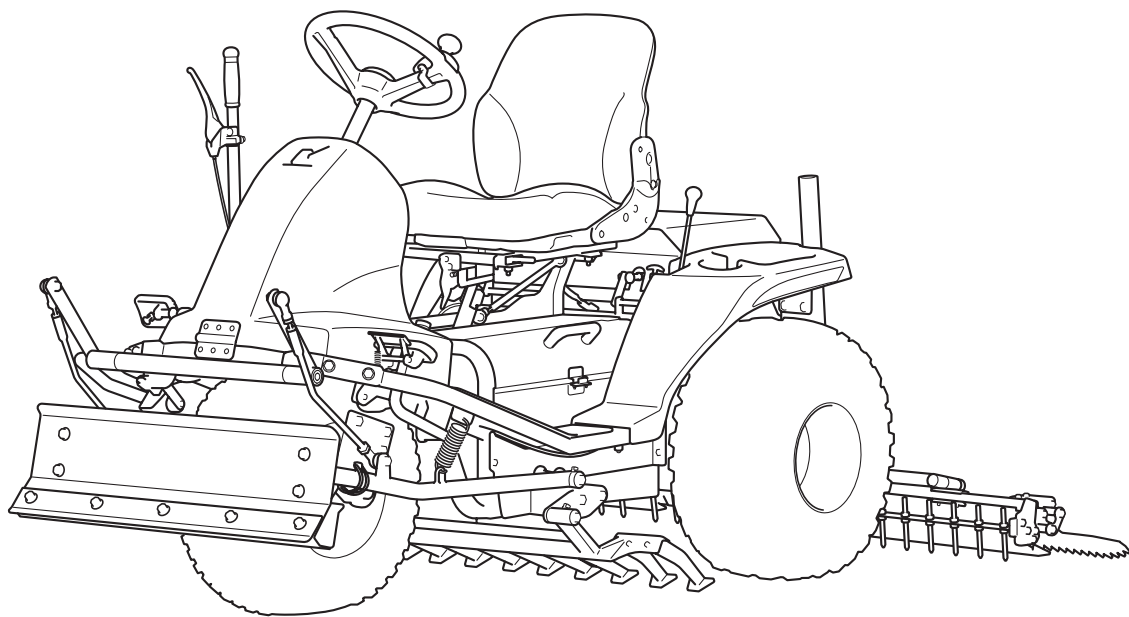

BARONESS
Quality on Demand

Greeting

Thank you for purchasing Baroness machine.

This machine has been shipped from the factory after comprehensive test runs and inspections. However, the optimum performance of the machine depends on how you use and maintain it, including routine inspections, adjustments, and fuel supplies before and after the operation.

We hope you will use the machine safely, and take advantage of its best performance.

Note

(For inquiry about this machine)

Since the type of machine may be changed sequentially, inform us of the type and the serial number.

The information described in this manual is subject to change without prior notice.

When replacing parts, be sure to use Baroness parts or parts designated by Kyo-eisha.

Note that the Baroness product warranty may not apply to defects caused by the use of parts from other companies.

(For ordering parts)

For prevention of delivery of wrong parts, be sure to inform us of the code number and the part name.

Example:	Code No.	Part Name	Qty
	K0200100002	WASHER, SPRING M10	8

<Indication of the connecting point shown on the other page>

(Example and description)

The following indication shows the connecting point of the part shown on the other page.

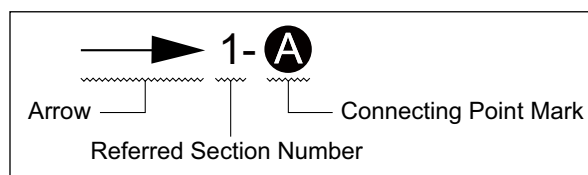

→ 1- **A** : Refer to the point **A** in the illustration of the section No.1

→ 2- **B** : Refer to the point **B** in the illustration of the section No.2

Contents

1. Frame section A P3	2. Frame section B P5	3. Frame section C P7	4. Cover section A P9
5. Cover section B P11	6. Steering section P13	7. Front wheel section (2-wheel drive)..... P15	8. Rear wheel section P17
9. Traveling section A P18	10. Traveling section B P20	11. Mission section A P21	12. Mission section B-1 P22
13. Mission section B-2 P23	14. Mission section B-3 P25	15. Mission section B-4 P26	16. Electrical section A P27
17. Electrical section B P28	18. Electrical section C P29	19. Electrical section D P31	20. Electrical section E P32

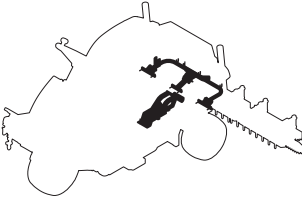
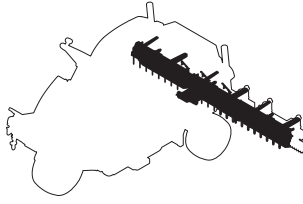
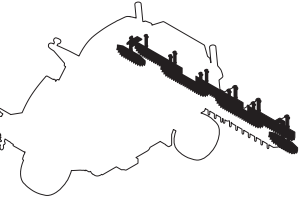
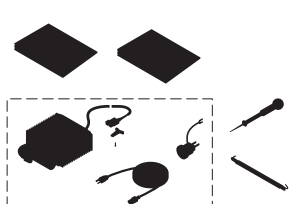
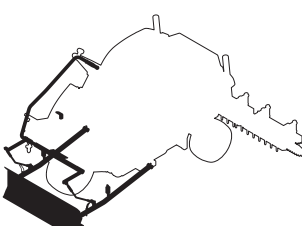
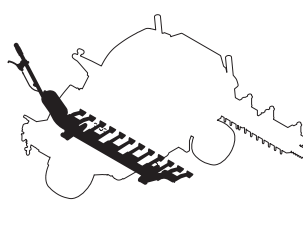
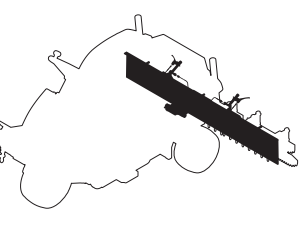
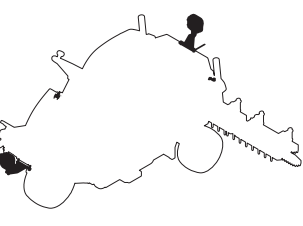
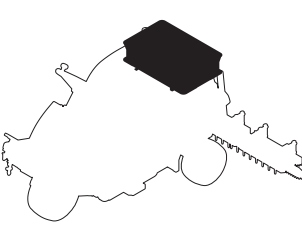
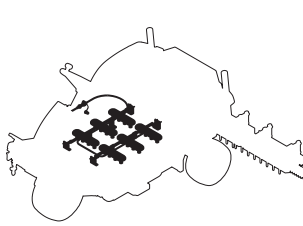
<p>21. Rake section A P33</p> 	<p>22. Rake section B P34</p> 	<p>23. Rake section C P36</p> 	<p>24. Accessory section P37</p> 
<p>25. Front blade section P38</p> 	<p>26. Sand cultivator section P39</p> 	<p>27. Finishing brush section P40</p> 	<p>28. Light section P41</p> 
<p>29. Cargo box section P42</p> 	<p>30. Water refilling system Kit section P43</p> 		

1. Frame section A

SP160EB

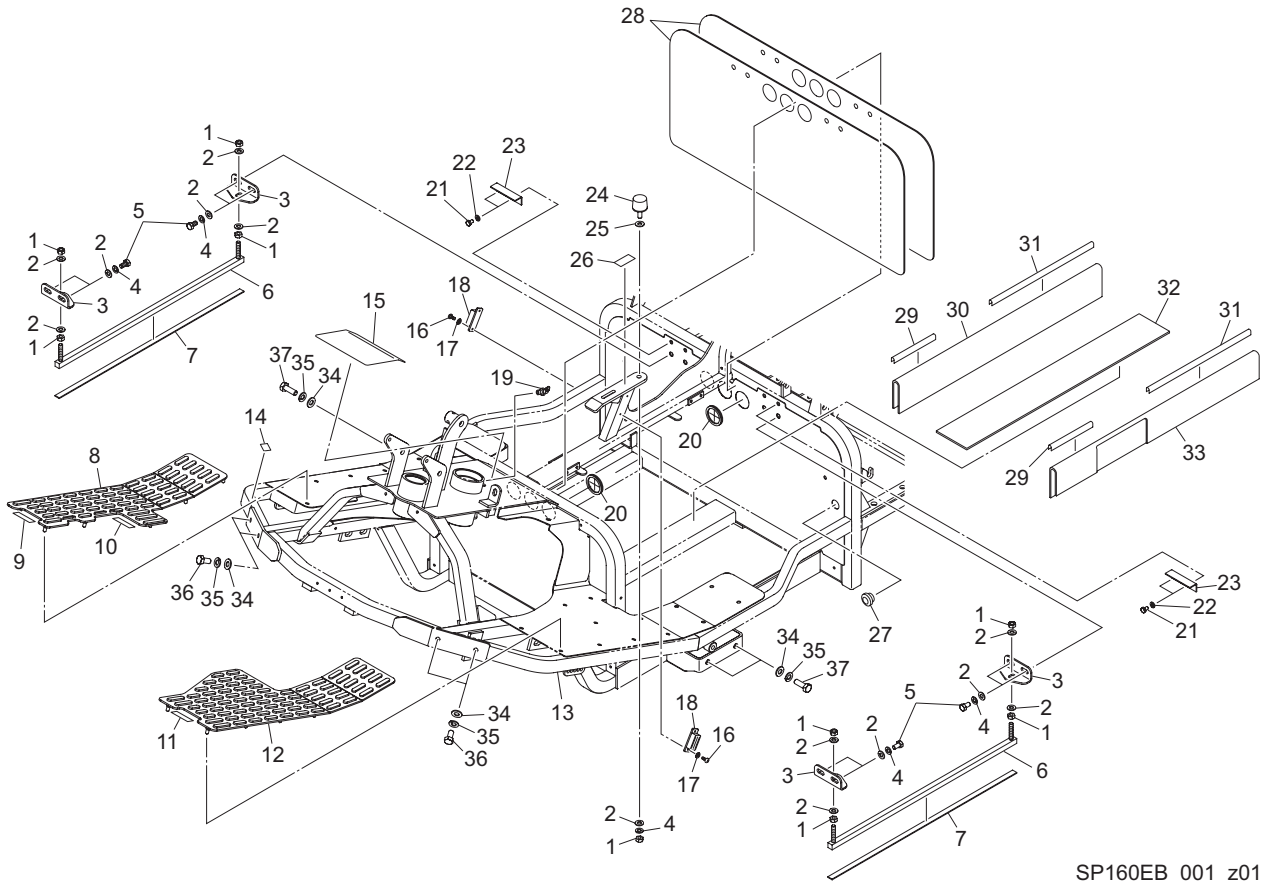

SP160EB_001_z01

Cat No.	Code No.	Part name	Qty	Remark	SN of application
1-1	K0100080002	NUT, M8	9		
1-2	K5000080002	WASHER, M8	17		
1-3	SP160E-0105ZD	BRACKET	4		
1-4	K0200080002	WASHER, SPRING M8	9		
1-5	K0000080152	BOLT, M8-15	8		
1-6	SP160E-3104ZD	CLAMPER, BATTERY	2		
1-7	SP160E-0106Z0	PLATE, RUBBER	2		
1-8	SP160EB0108Z0	MAT, STEP (RH)	1		
1-9	K4203001430	DECAL, FORWARD	1		
1-10	K4203001440	DECAL, BACKWARD	1		
1-11	K4203001450	DECAL, BRAKE	1		
1-12	SP160EB0109Z0	MAT, STEP (LH)	1		
1-13	SP160EB0101ZD	FRAME, MAIN	1		
1-14	SP160EB0102Z0	TAPE, WEAR-RESISTANCE	1		
1-15	SP160EB0103Z0	DECAL, WARNING	1		
1-16	K0042030102	SCREW, + ROUND HEAD M3-10	4		
1-17	K0200030002	WASHER, SPRING M3	4		
1-18	K1510000050	MAGNET, CATCH SMALL	2		
1-19	K1440000030	GREASE NIPPLE, 67.5 DEG TYPE B	1		
1-20	K0900300380	GROMMET, W/SEALING C30SG38A	6		
1-21	K0000060102	BOLT, M6-10	4		
1-22	K0200060002	WASHER, SPRING M6	4		
1-23	SP160E-0113ZD	ANGLE	2		
1-24	K4039000100	RUBBER, STOPPER	1		
1-25	K5011008182	WASHER, SPCC 1-8-18	0-3	For adjustment	
1-26	K4205001930	DECAL, CAUTION TO INJURE	1		
1-27	K0900300200	GROMMET, W/SEALING C30SG20A	1		
1-28	SP160EB0107Z0	RUBBER, ANTI CORROSION (FRONT/REAR)	2		
1-29	K3197101000	TRIM, AL 100-64-100	2		
1-30	SP160EB0106Z0	RUBBER, ANTI CORROSION (RH)	1		

1. Frame section A

SP160EB

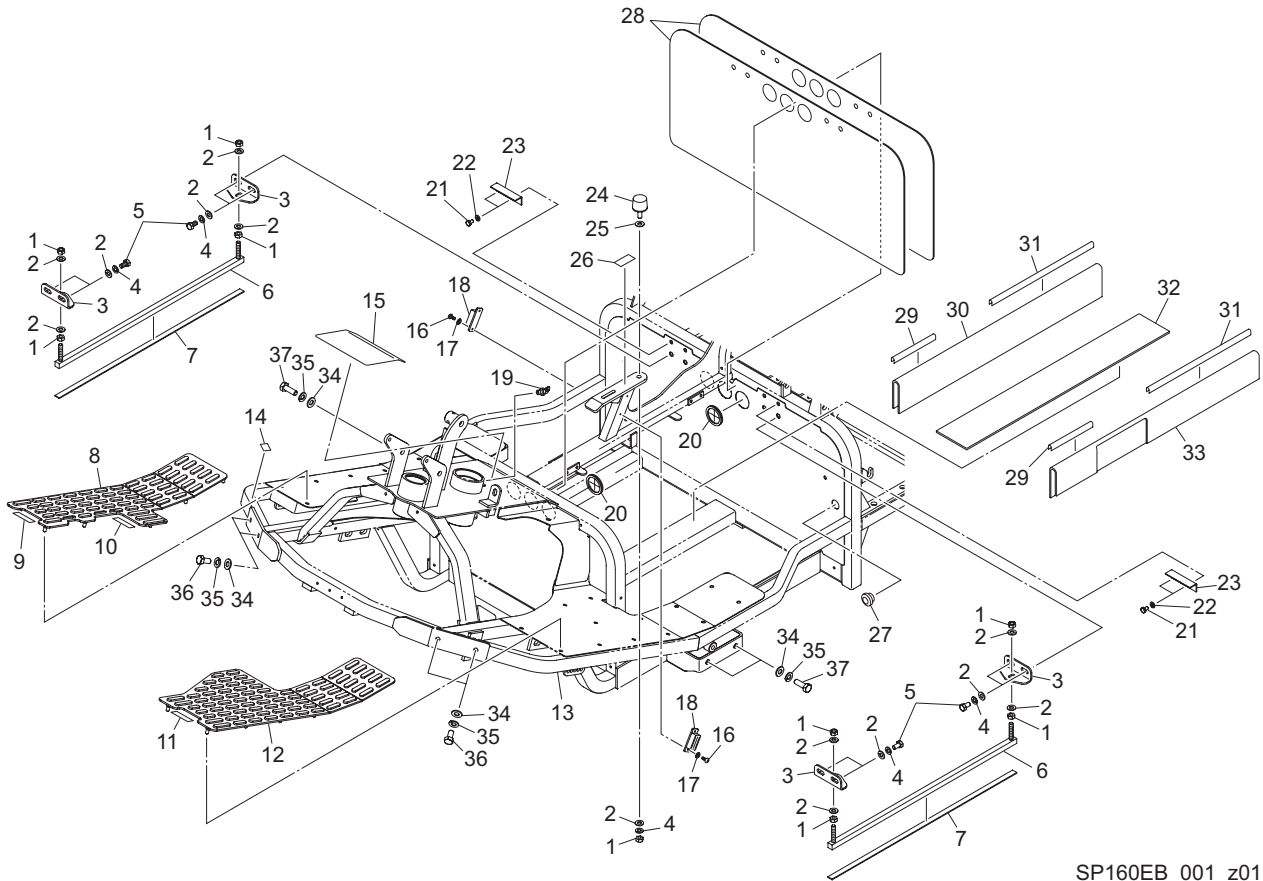

SP160EB_001_z01

Cat No.	Code No.	Part name	Qty	Remark	SN of application
1-31	K3197103000	TRIM, AL 100-64-300	2		
1-32	SP160EB0104Z0	RUBBER, ANTI CORROSION (CENTER)	1		
1-33	SP160EB0105Z0	RUBBER, ANTI CORROSION (LH)	1		
1-34	K5000100002	WASHER, M10	8		
1-35	K0200100002	WASHER, SPRING M10	8		
1-36	K0000100202	BOLT, M10-20	4		
1-37	K0000100302	BOLT, M10-30	4		

2. Frame section B

SP160EB

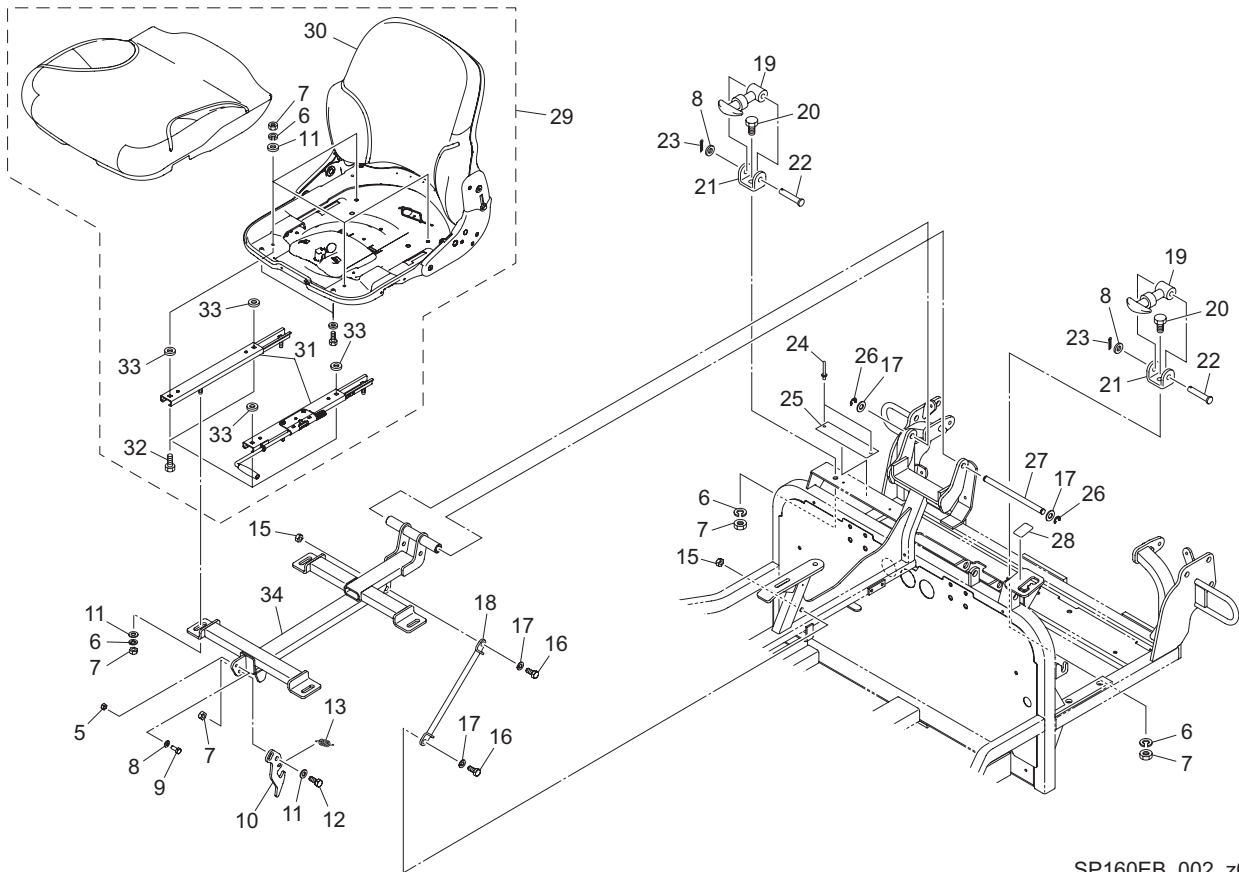

SP160EB_002_z01

Cat No.	Code No.	Part name	Qty	Remark	SN of application
2-1					
2-2					
2-3					
2-4					
2-5	K0100060002	NUT, M6	1		
2-6	K0200080002	WASHER, SPRING M8	10		
2-7	K0100080002	NUT, M8	11		
2-8	K5000060002	WASHER, M6	3		
2-9	K0000060202	BOLT, M6-20	1		
2-10	SP160EB0112ZD	CLAMPER, SEAT BASE	1		
2-11	K5000080002	WASHER, M8	9		
2-12	K0000080202	BOLT, M8-20	1		
2-13	K1030000108	SPRING, W/U HOOK M1.2-9.4-35	1		
2-14	SP160EB0110ZD	BASE, SEAT	1		
2-15	K0100100002	NUT, M10	2		
2-16	K0000100202	BOLT, M10-20	2		
2-17	K5000100002	WASHER, M10	4		
2-18	K3381000050	GAS-SPRING, KSF100-10	1		
2-19	K1520000090	HOOK, RUBBER SMALL	2		
2-20	K0000080152	BOLT, M8-15	2		
2-21	K5200000102	BRACKET, RUBBER HOOK	2		
2-22	K6030060352	PIN, FLAT HEAD M6-35	2		
2-23	K0300016202	PIN, COTTER M1.6-20	2		
2-24	K4510614140	RIVET, BLIND AVEX 1661-0414	2		
2-25	K4200000300	NAMEPLATE	1		
2-26	K0400008002	RING, RETAINING E M8	2		
2-27	SP160EB0111Z0	SHAFT, FULCRUM SEAT BASE	1		
2-28	SP160E-0131Z0	DECAL, INDICATING SHIFT	1		
2-29	K1700000510	SEAT, SGA NC W/RAIL	1		
2-30	K1700000450	SEAT, SGA 18210 NC	1		

2. Frame section B

SP160EB

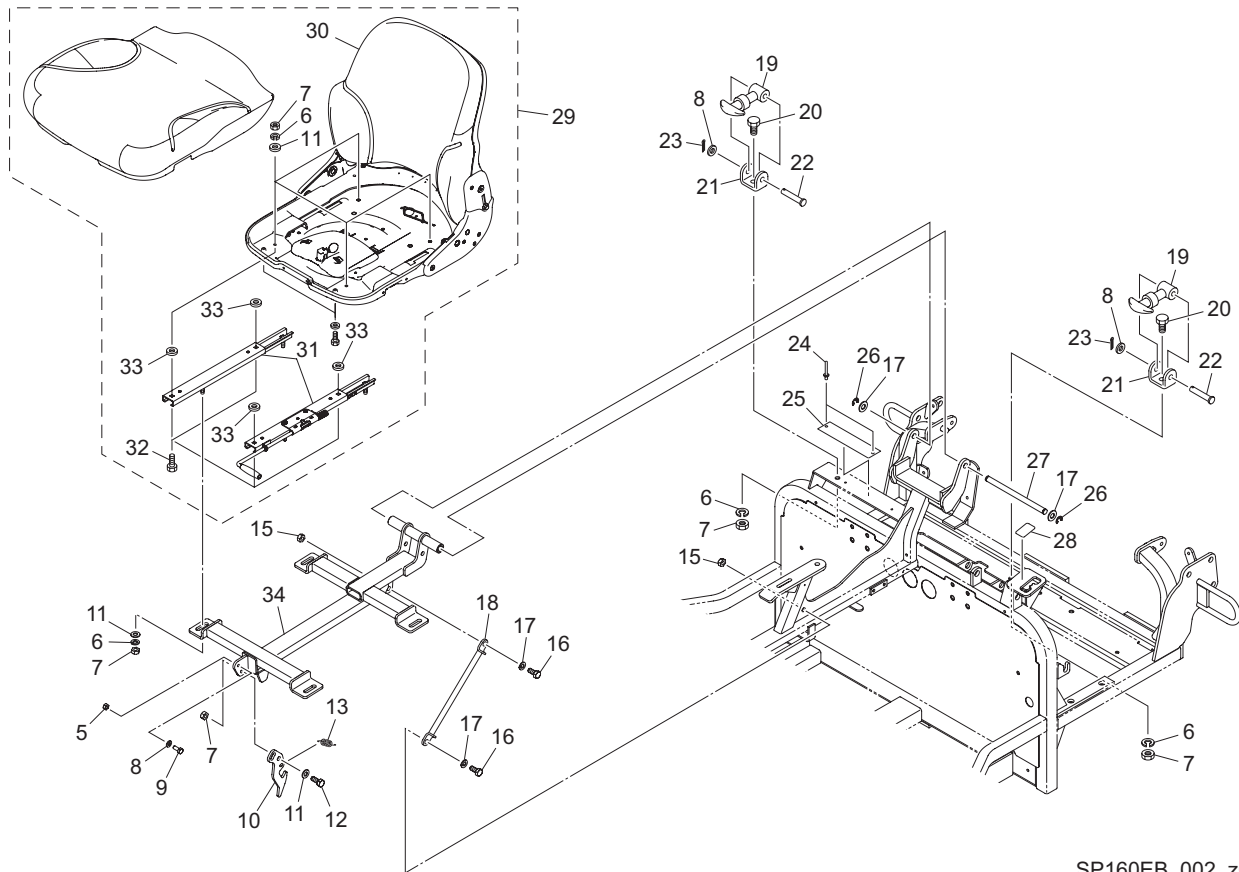

SP160EB_002_z01

Cat No.	Code No.	Part name	Qty	Remark	SN of application
2-31	K1701000170	RAIL, SLIDE SGA	1		
2-32	K0000080252	BOLT, M8-25	4		
2-33	K5074510262	WASHER, SPHC 4.5-10-26	4		
2-34	SP160EB0126ZD	BASE, SEAT	1		

3. Frame section C

SP160EB

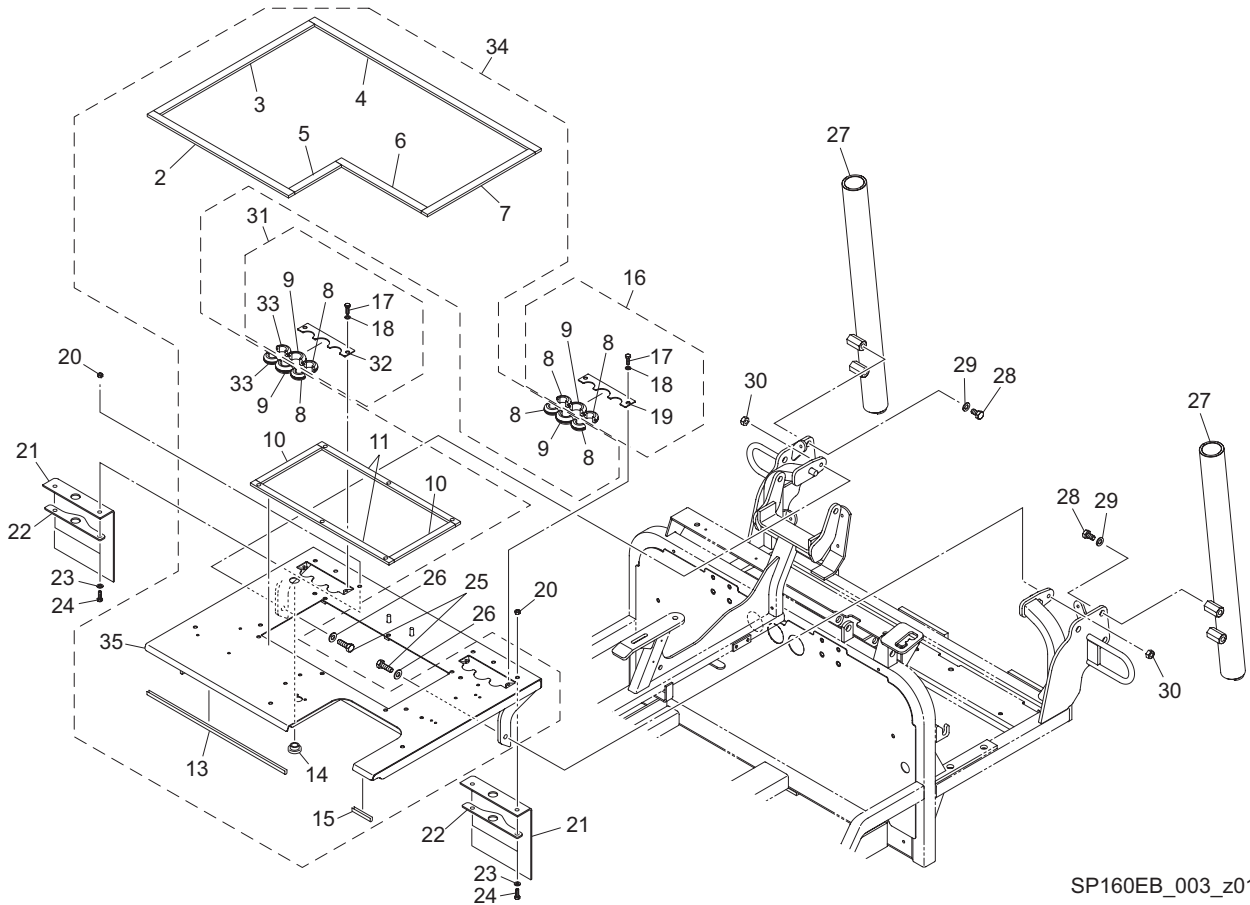

SP160EB_003_z01

Cat No.	Code No.	Part name	Qty	Remark	SN of application
3-1					
3-2	SP160E-0117Z0	SPONGE, RUBBER 345-15	1		
3-3	SP160EB0119Z0	SPONGE, RUBBER 380-15	1		
3-4	SP160E-0119Z0	SPONGE, RUBBER 555-15	1		
3-5	SP160EB0117Z0	SPONGE, RUBBER 115-15	1		
3-6	SP160E-0115Z0	SPONGE, RUBBER 220-15	1		
3-7	SP160EB0118Z0	SPONGE, RUBBER 250-15	1		
3-8	SP160EB0115Z0	RUBBER, DUST PROOF (SMALL)	6		
3-9	SP160EB0114Z0	RUBBER, DUST PROOF (LARGE)	4		
3-10	SP160EB0124Z0	SPONGE, RUBBER 150-12	2		
3-11	SP160EB0125Z0	SPONGE, RUBBER 336-12	2		
3-12					
3-13	K3197003200	TRIM, AL 75-16-320	1		
3-14	K0900300160	GROMMET, W/SEALING C30SG16A	1		
3-15	K3197000400	TRIM, AL 75-16-40	1		
3-16	SP160EB0131Z0	PLATE ASSY, FIXING HARNESS	1		
3-17	K0000050152	BOLT, M5-15	4		
3-18	K0200050002	WASHER, SPRING M5	4		
3-19	SP160EB0116ZD	PLATE, FIXING HARNESS	1		
3-20	K0144060002	NUT, W/F-RING M6	4		
3-21	SP160EB0123Z0	PLATE, RUBBER 2-140-180 W/ HOLE	2		
3-22	SP160EB0122ZD	CLAMPER, RUBBER PLATE	2		
3-23	K0200060002	WASHER, SPRING M6	4		
3-24	K0000060202	BOLT, M6-20	4		
3-25	K0000080252	BOLT, M8-25	2		
3-26	K5000080002	WASHER, M8	2		
3-27	SP160EB0121ZD	PIPE, BROOM STAND	2		
3-28	K0000100152	BOLT, M10-15	4		
3-29	K0200100002	WASHER, SPRING M10	4		
3-30	K0100080002	NUT, M8	2		

3. Frame section C

SP160EB

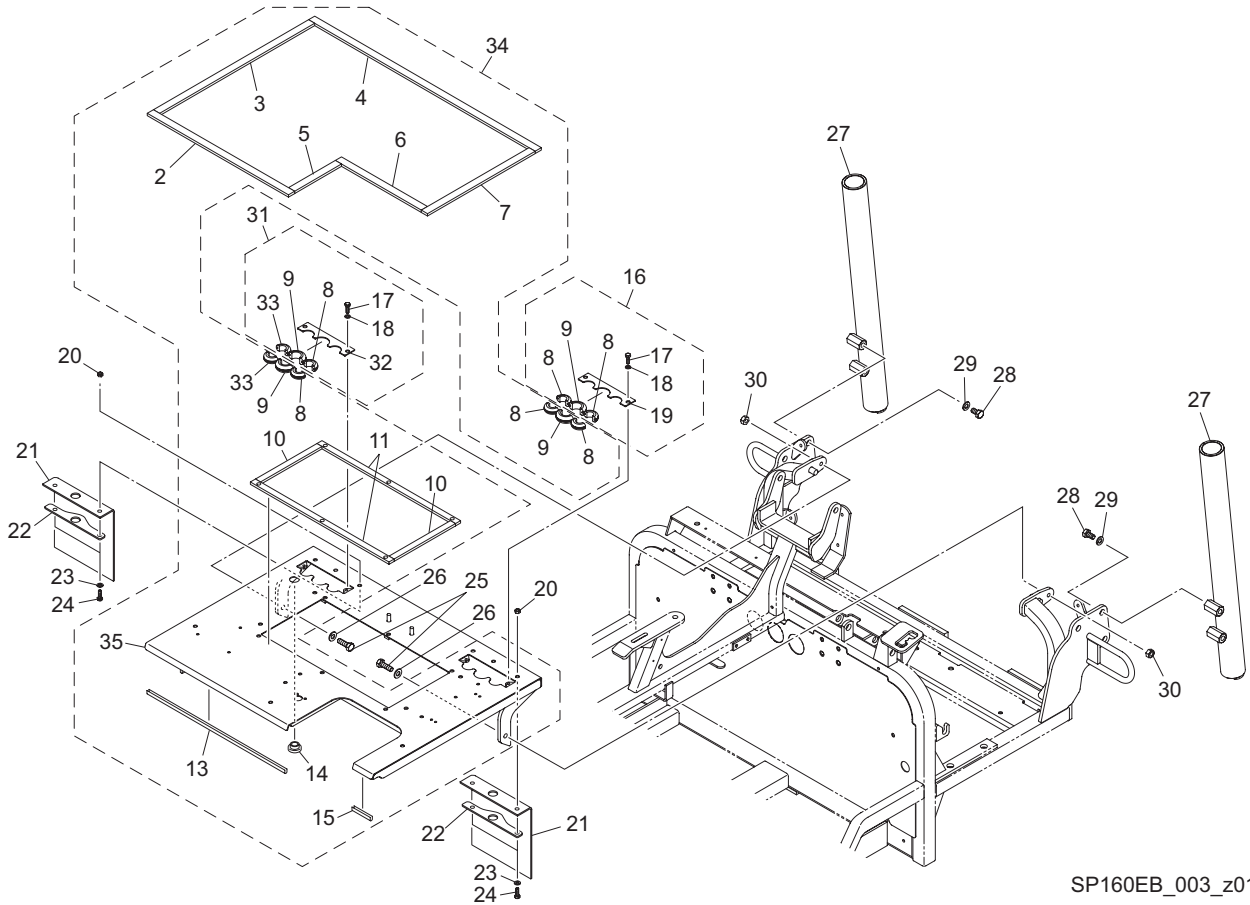

SP160EB_003_z01

Cat No.	Code No.	Part name	Qty	Remark	SN of application
3-31	SP160EB0136Z0	PLATE ASSY, FIXING HARNESS	1		
3-32	SP160EB0137ZD	PLATE, FIXING HARNESS (SMALL)	1		
3-33	SP160EB0138Z0	RUBBER, DUST PROOF	2		
3-34	SP160EB0132Z0	STAND ASSY, DRIVER	1		
3-35	SP160EB0133ZD	BASE, DRIVER	1		

4. Cover section A

SP160EB

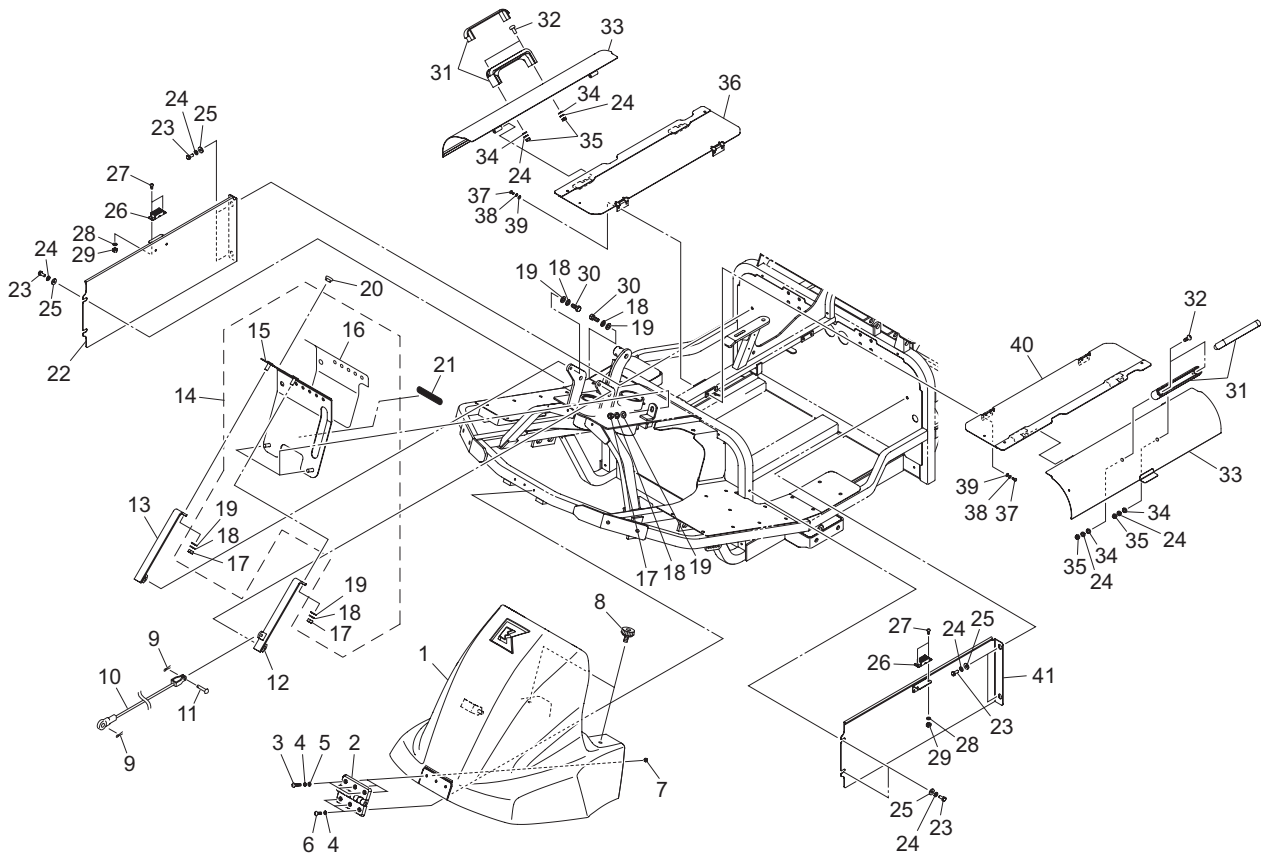

SP160EB_004_z02

Cat No.	Code No.	Part name	Qty	Remark	SN of application
4-1	SP160EB0301Z0	COVER COMP, FRONT	1		
4-2	K4520000260	HINGE, RESIN W/HOLE 5.2-100	1		
4-3	K0042050252	SCREW, + ROUND HEAD M5-25	3		
4-4	K0200050002	WASHER, SPRING M5	6		
4-5	K5000050002	WASHER, M5	3		
4-6	K0042050152	SCREW, + ROUND HEAD M5-15	3		
4-7	K0100050002	NUT, M5	3		
4-8	K1320000250	KNOB, DIMPLE M8-16	2		
4-9	K0300020202	PIN, COTTER M2-20	2		
4-10	K1170037000	WIRE, HOOK 370	1		
4-11	K6040060282	PIN, ROUND HEAD M6-28	1		
4-12	SP160EB0308ZD	STAY, PANEL (LH)	1		
4-13	SP160EB0307ZD	STAY, PANEL (RH)	1		
4-14	SP160EB0304Z0	PANEL COMP, OPERATING	1		
4-15	SP160EB0305ZD	PANEL, OPERATING	1		
4-16	SP160EB0306Z0	STICKER, OPERATING PANEL	1		
4-17	K0100080002	NUT, M8	4		
4-18	K0200080002	WASHER, SPRING M8	6		
4-19	K5000080002	WASHER, M8	6		
4-20	K0900300120	GROMMET, W/SEALING C30SG12A	1		
4-21	K4205001660	DECAL, NOT TO DRIVE AT PUBLIC ROAD	1		
4-22	SP160EB0313ZR	PLATE, SIDE BATTERY (RH)	1		
4-23	K0000060152	BOLT, M6-15	8		
4-24	K0200060002	WASHER, SPRING M6	12		
4-25	K5012306162	WASHER, SPCC 2.3-6-16	8		
4-26	K1510000050	MAGNET, CATCH SMALL	2		
4-27	K0042030102	SCREW, + ROUND HEAD M3-10	4		
4-28	K0200030002	WASHER, SPRING M3	4		
4-29	K0100030002	NUT, M3	4		
4-30	K0000080202	BOLT, M8-20	2		

4. Cover section A

SP160EB

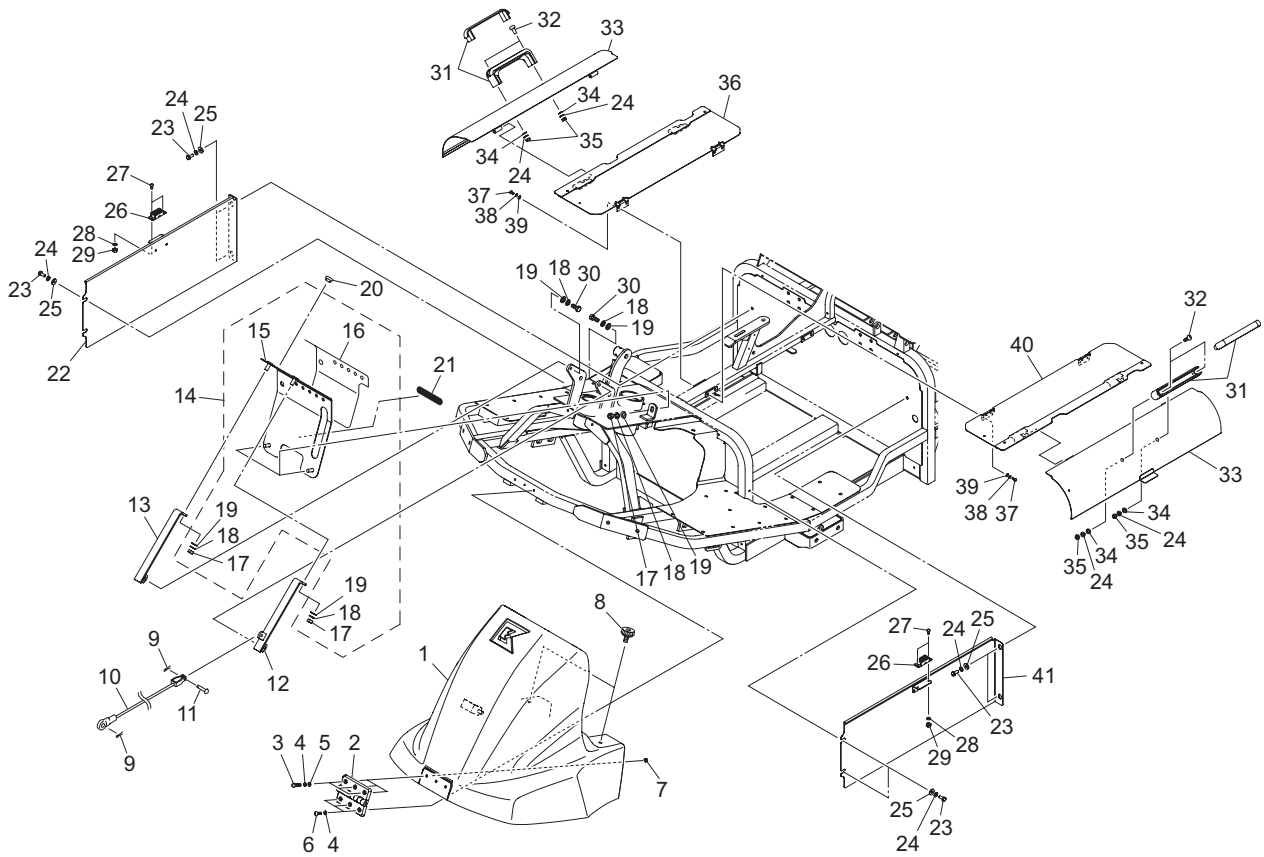

SP160EB_004_z02

Cat No.	Code No.	Part name	Qty	Remark	SN of application
4-31	K1301000160	GRIP, PLASTIC HANDLE	2		
4-32	K0042060152	SCREW, + ROUND HEAD M5-40	4		
4-33	SP160EB0311ZR	COVER, BATTERY B	2		
4-34	K5000060002	WASHER, M6	4		
4-35	K0100060002	NUT, M6	4		
4-36	SP160EB0310ZR	COVER, BATTERY A (RH)	1		
4-37	K0043040120	SCREW, SUS ROUND HEAD M4-12	8		
4-38	K0200040002	WASHER, SPRING M4	8		
4-39	K5000040002	WASHER, M4	8		
4-40	SP160EB0309ZR	COVER, BATTERY A (LH)	1		
4-41	SP160EB0312ZR	PLATE, SIDE BATTERY (LH)	1		

5. Cover section B

SP160EB

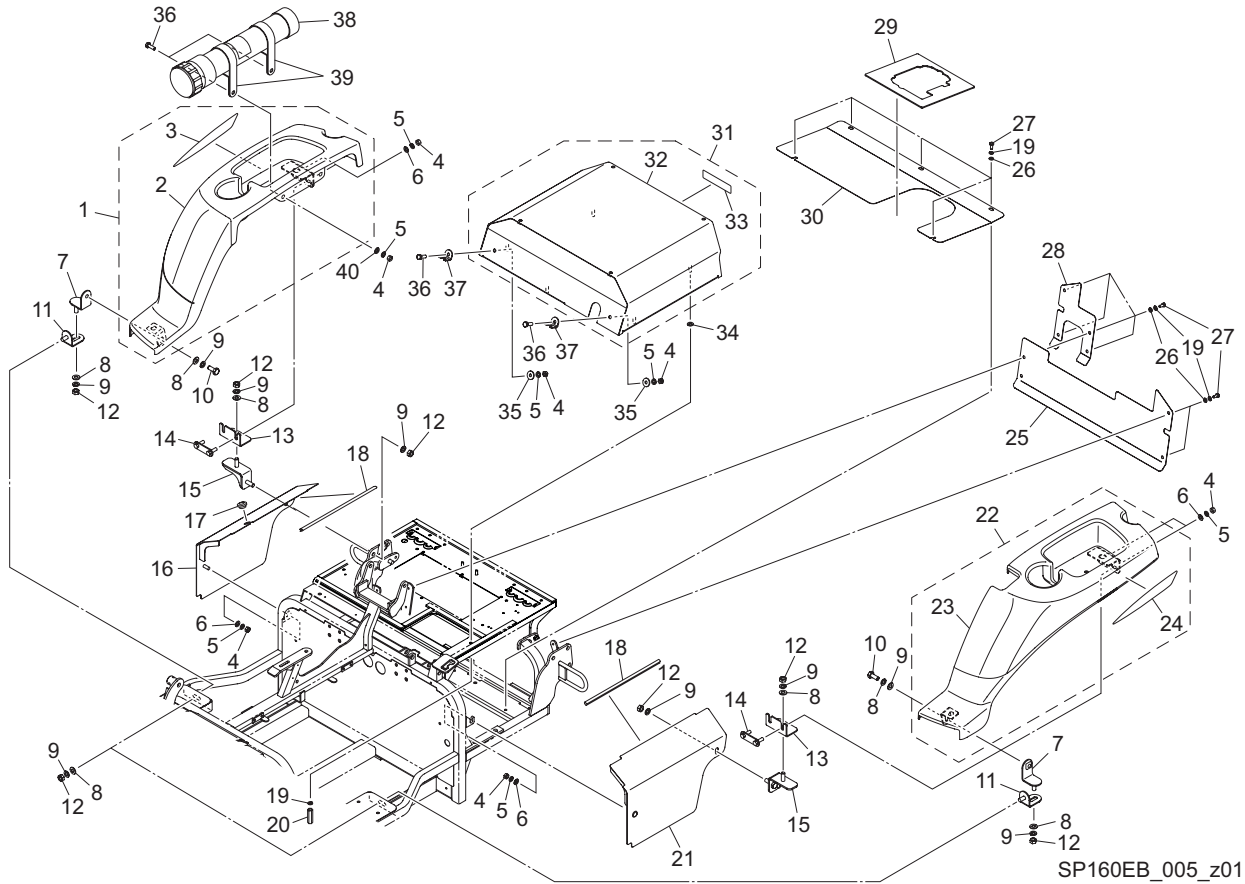

SP160EB_005_z01

Cat No.	Code No.	Part name	Qty	Remark	SN of application
5-1	SP160EB0336A0	COVER ASSY, REAR (RH)	1		
5-2	SP160EB0328B0	COVER COMP, REAR (RH)	1		
5-3	SP160EB0316Z0	STICKER, SP160EB (RH)	1		
5-4	K0100080002	NUT, M8	10		
5-5	K0200080002	WASHER, SPRING M8	10		
5-6	K5000080002	WASHER, M8	6		
5-7	SP160EB0334Z2	BRACKET, B FOR REAR COVER	2		
5-8	K5000100002	WASHER, M10	8		
5-9	K0200100002	WASHER, SPRING M10	10		
5-10	K0000100252	BOLT, M10-25	2		
5-11	SP160EB0333Z2	BRACKET, A FOR REAR COVER	2		
5-12	K0100100002	NUT, M10	8		
5-13	SP160EB0331ZD	PLATE, ADJUSTING	2		
5-14	SP160EB0330Z2	CLAMPER, 2-50 W/M8 BOLT	2		
5-15	SP160EB0332ZD	BRACKET, COVER	2		
5-16	SP160EB0319ZD	COVER, REAR SIDE (RH)	1		
5-17	K0900300160	GROMMET, W/SEALING C30SG16A	1		
5-18	K3197003000	TRIM, AL 75-16-300	2		
5-19	K0200060002	WASHER, SPRING M6	16		
5-20	K0149060252	NUT, HIGH M6-10- 25	5		
5-21	SP160EB0318ZD	COVER, REAR SIDE (LH)	1		
5-22	SP160EB0335A0	COVER ASSY, REAR (LH)	1		
5-23	SP160EB0324A0	COVER COMP, REAR (LH)	1		
5-24	SP160EB0317Z0	STICKER, SP160EB (LH)	1		
5-25	SP160EB0322ZD	COVER, REAR (LH)	1		
5-26	K5000060002	WASHER, M6	11		
5-27	K0000060152	BOLT, M6-15	11		
5-28	SP160EB0323ZD	COVER, BACK (RH)	1		
5-29	SP160EB0321Z0	RUBBER, DUST PROOF	1		
5-30	SP160EB0320ZD	COVER, UNDER MOTOR	1		

5. Cover section B

SP160EB

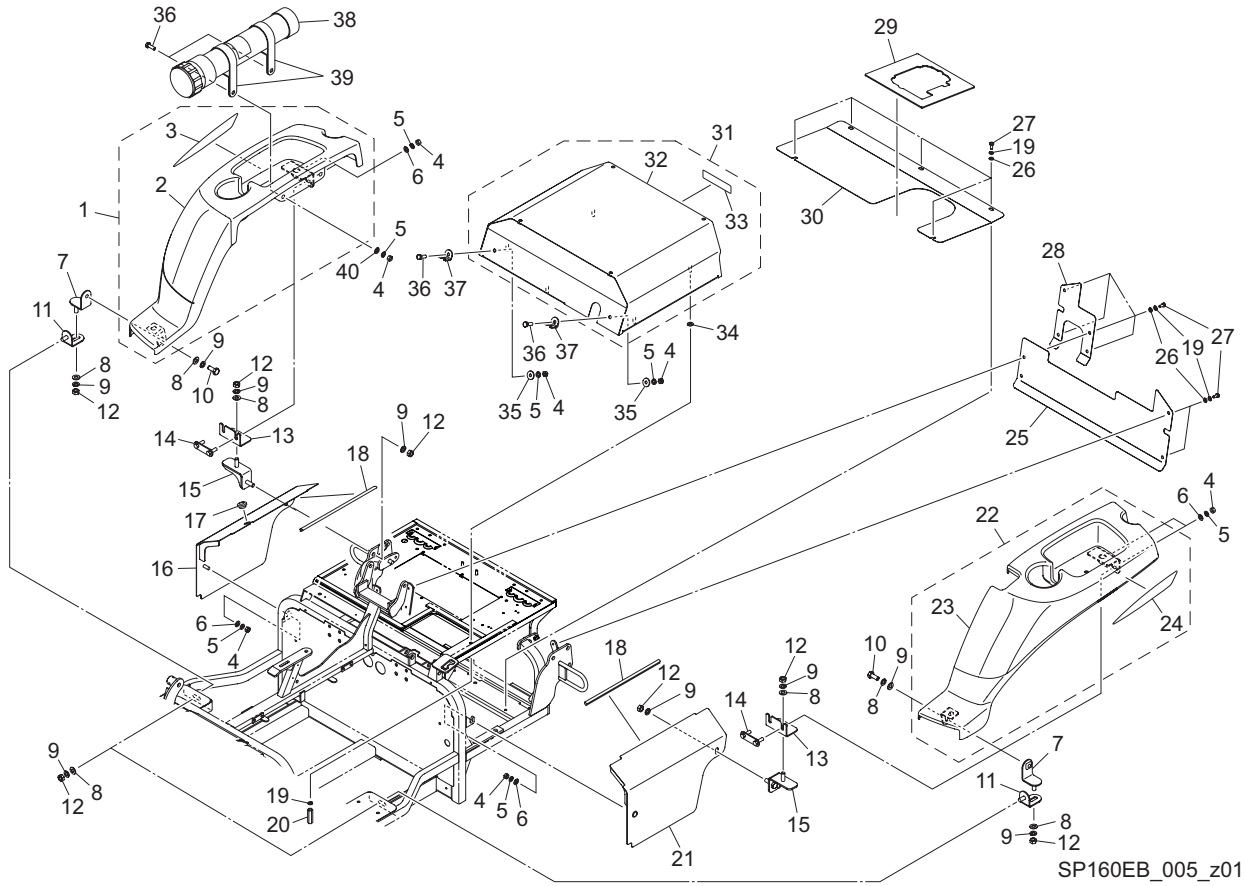

Cat No.	Code No.	Part name	Qty	Remark	SN of application
5-31	SP160EB0314B0	COVER COMP, DRIVER	1		
5-32	SP160EB0315BR	COVER, DRIVER	1		
5-33	K4201000610	STICKER, BARONESS 147	1		
5-34	K5012306162	WASHER, SPCC 2.3-6-16	5		
5-35	K5012308242	WASHER, SPCC 2.3-8-24	2		
5-36	K0000080252	BOLT, M8-25	4		
5-37	K5270002352	RECEIVER, RUBBER HOOK	2		
5-38	K5920000130	CASE, FOR MANUALS	1		
5-39	SP160EB1001ZD	BRACKET, FOR MANUALS CASE	2		
5-40	K5012308242	WASHER, SPCC 2.3-8-24	2		

6. Steering section

SP160EB

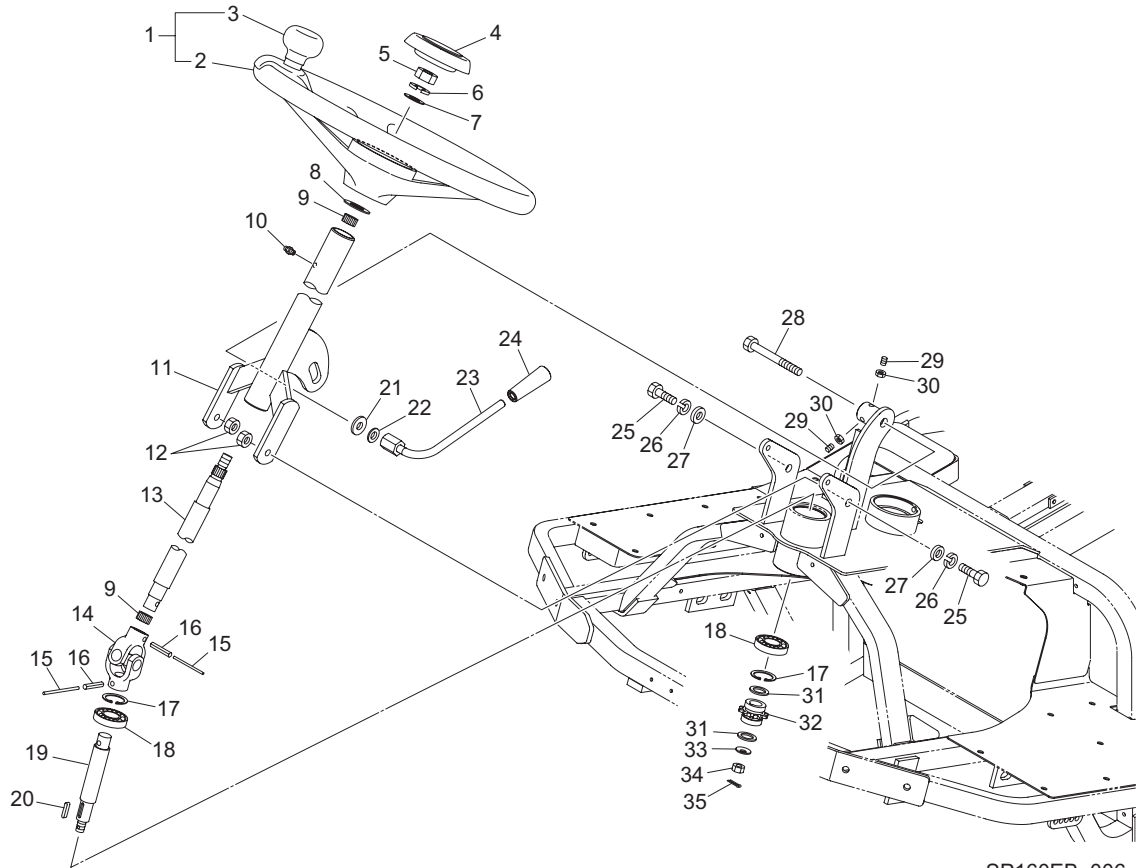

SP160EB_006_z00

Cat No.	Code No.	Part name	Qty	Remark	SN of application
6-1	K1710000070	STEERING, W/KNOB V027220-0000	1		
6-2	K1710000080	STEERING, V027220-0101	1		
6-3	K1710000090	KNOB ASSY, V027220-0200	1		
6-4	K1310000130	CAP, RUBBER	1		
6-5	K0108120002	NUT, P1.25 M12-3	1		
6-6	K0200120002	WASHER, SPRING M12	1		
6-7	K5000120002	WASHER, M12	1		
6-8	K5051018300	WASHER, C5191P 1-18-30	1		
6-9	K0721815000	BEARING, NEEDLE TAZ 1815	2		
6-10	K1440000010	GREASE NIPPLE, STRAIGHT TYPE A	1		
6-11	SP160EB0202ZD	FRAME, HANDLE	1		
6-12	K0100100002	NUT, M10	2		
6-13	SP160EA0203Z0	SHAFT, HANDLE	1		
6-14	K1620000080	JOINT, HJ-RR-0012	1		
6-15	K4980001000	WIRE, SUS 1.2-100	2		
6-16	K0324060321	PIN, SPIRAL M6-32	2		
6-17	K0402042001	RING, RETAINING R M42	2		
6-18	K0612060040	BEARING, BALL SEAL 2RD 6004	2		
6-19	SP160E-3205A0	SHAFT, STEERING GEAR	1		
6-20	K0500404200	KEY, BOTH ROUND M4-420	1		
6-21	K5073212352	WASHER, SPHC 3.2-12-35	1		
6-22	K0213120002	WASHER, DISK SPRING 1H M12	1		
6-23	SP160EB0203ZD	LEVER, TILTING	1		
6-24	K1300000070	GRIP, RUBBER BLACK 9-22	1		
6-25	K0000100252	BOLT, M10-25	2		
6-26	K0212100001	WASHER, DISK SPRING 1L M10	2		
6-27	K5000100002	WASHER, M10	2		
6-28	K0000120602	BOLT, M12-60	1		
6-29	K0023080151	SETSCREW, M8-15	2		
6-30	K0100080002	NUT, M8	2		

6. Steering section

SP160EB

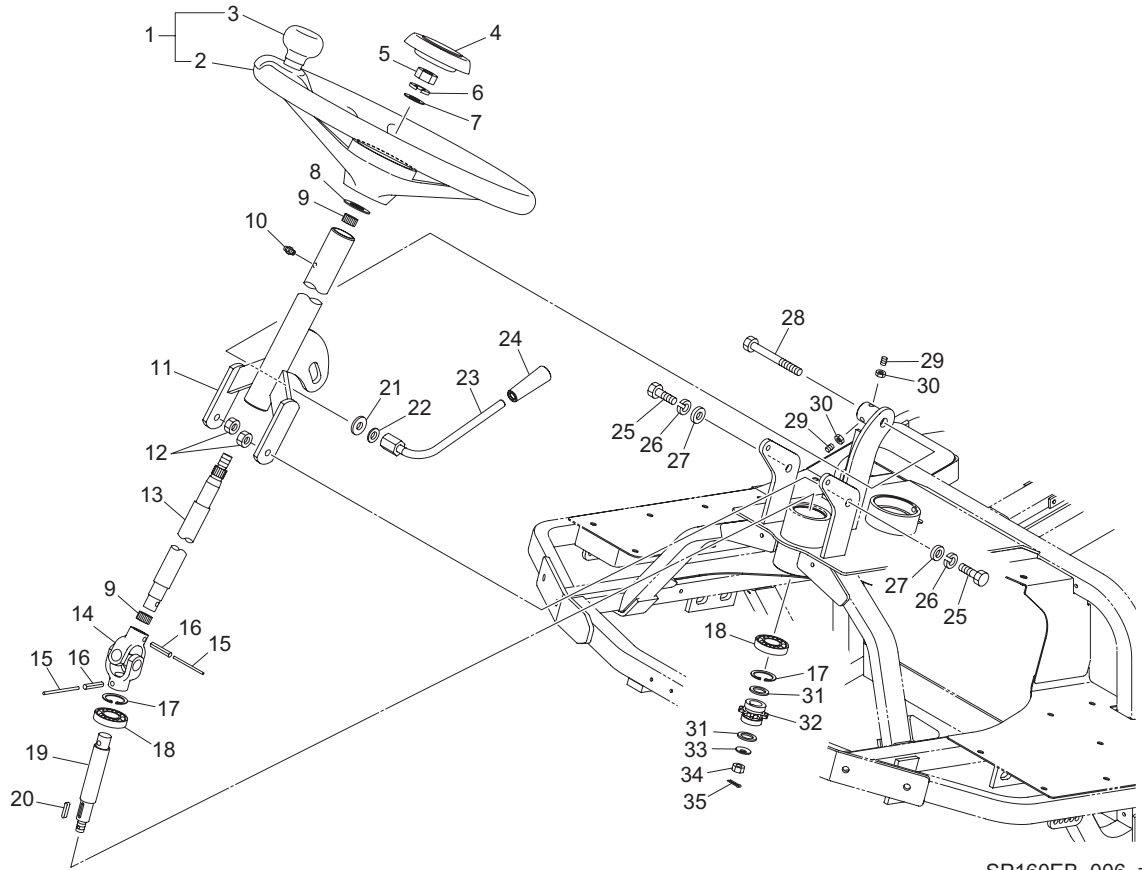

SP160EB_006_z00

Cat No.	Code No.	Part name	Qty	Remark	SN of application
6-31	K5011016222	WASHER, SPCC 1-16-22	2		
6-32	AM165--0206Z0	SPROCKET, 9.525-11	1		
6-33	K0210100002	SPRING, CONICAL DISC L M10	1		
6-34	K0124100002	NUT, THIN SLOTTED M10	1		
6-35	K0302025250	PIN, COTTER SUS M2.5-25	1		

7. Front wheel section

SP160EB

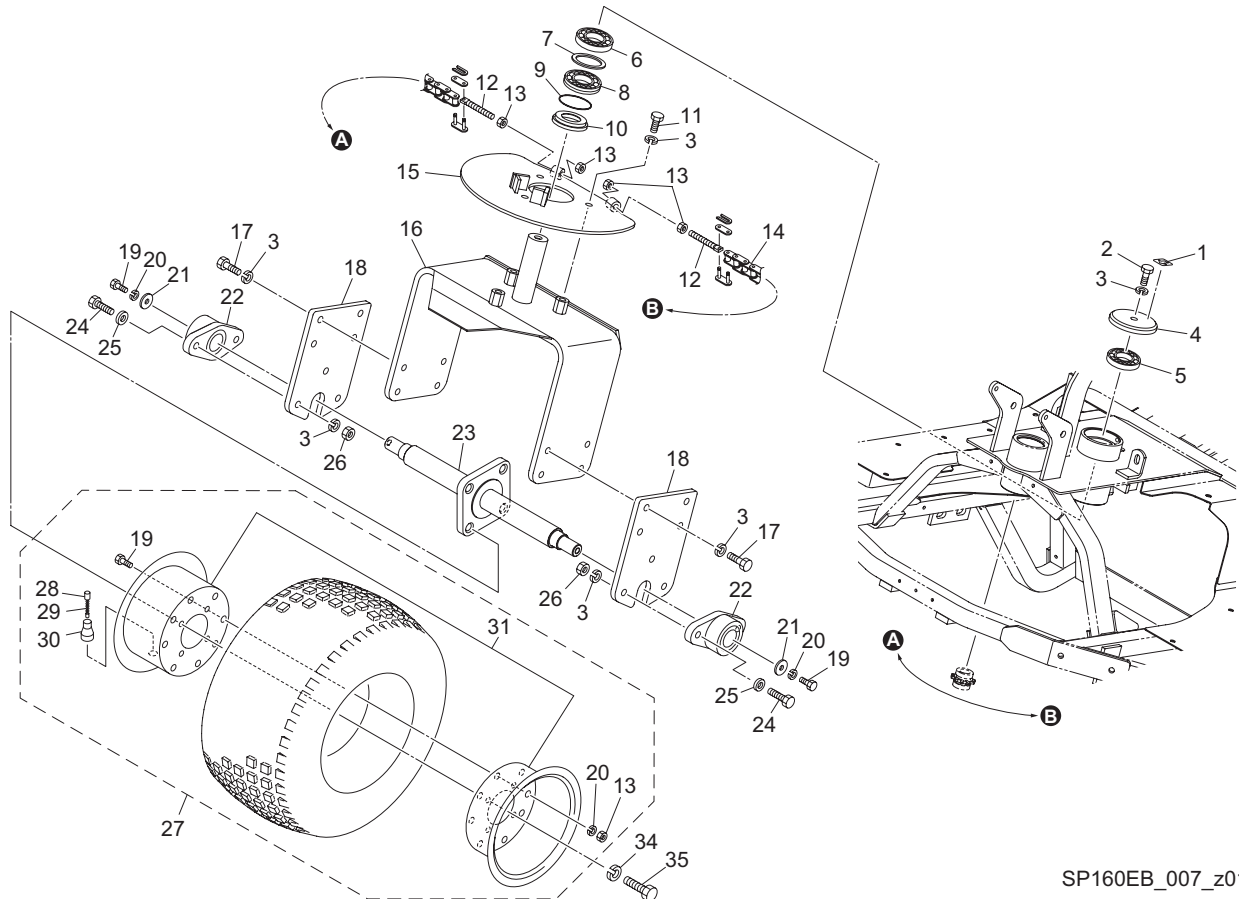

SP160EB_007_z01

Cat No.	Code No.	Part name	Qty	Remark	SN of application
7-1	K4209001180	DECAL, ARROW POINT	1		
7-2	K0000100202	BOLT, M10-20	1		
7-3	K0200100002	WASHER, SPRING M10	16		
7-4	SP160EB0201ZD	COVER, FRONT WHEEL	1		
7-5	K0612060060	BEARING, BALL SEAL 2RD 6006	1		
7-6	K0600069060	BEARING, BALL 6906	1		
7-7	K5011040522	WASHER, SPCC 1-40-52	1		
7-8	K0640512060	BEARING, BALL THRUST 51206	1		
7-9	K0880048000	O-RING, P48	1		
7-10	AM165--0203Z2	RECEIVER, THRUST BEARING	1		
7-11	K0010100202	BOLT, HT M10-20	3		
7-12	K6122000142	SHAFT, TAPPED W/HOLE M8-70	2		
7-13	K0100080002	NUT, M8	12		
7-14	K2210000430	CHAIN, EK35NEW-71JJ	1		
7-15	SP160E-0201AD	WHEEL, CHAIN	1		
7-16	SP160E-0202ZD	ARM, FRNT WHEEL	1		
7-17	K0000100252	BOLT, M10-25	8		
7-18	AM165--0213AD	BRACKET, FRONT WHEEL	2		
7-19	K0000080152	BOLT, M8-15	10		
7-20	K0200080002	WASHER, SPRING M8	10		
7-21	K5012308242	WASHER, SPCC 2.3-8-24	2		
7-22	K0661204010	BEARING, BALL W/RHOMBIC UCFL204L2	2		
7-23	SP160E-3207A2	SHAFT, FRONT WHEEL	1		
7-24	K0000100352	BOLT, M10-35	4		
7-25	K5000100002	WASHER, M10	4		
7-26	K0100100002	NUT, M10	4		
7-27	K2000000190	TIRE ASSY, 21*11.00-10	1		
7-28	K2093000010	CAP, VALVE	1		
7-29	K2092000020	CORE, VALVE NO.9000	1		
7-30	K2097000040	VALVE, RIM PVR70	1		

7. Front wheel section

SP160EB

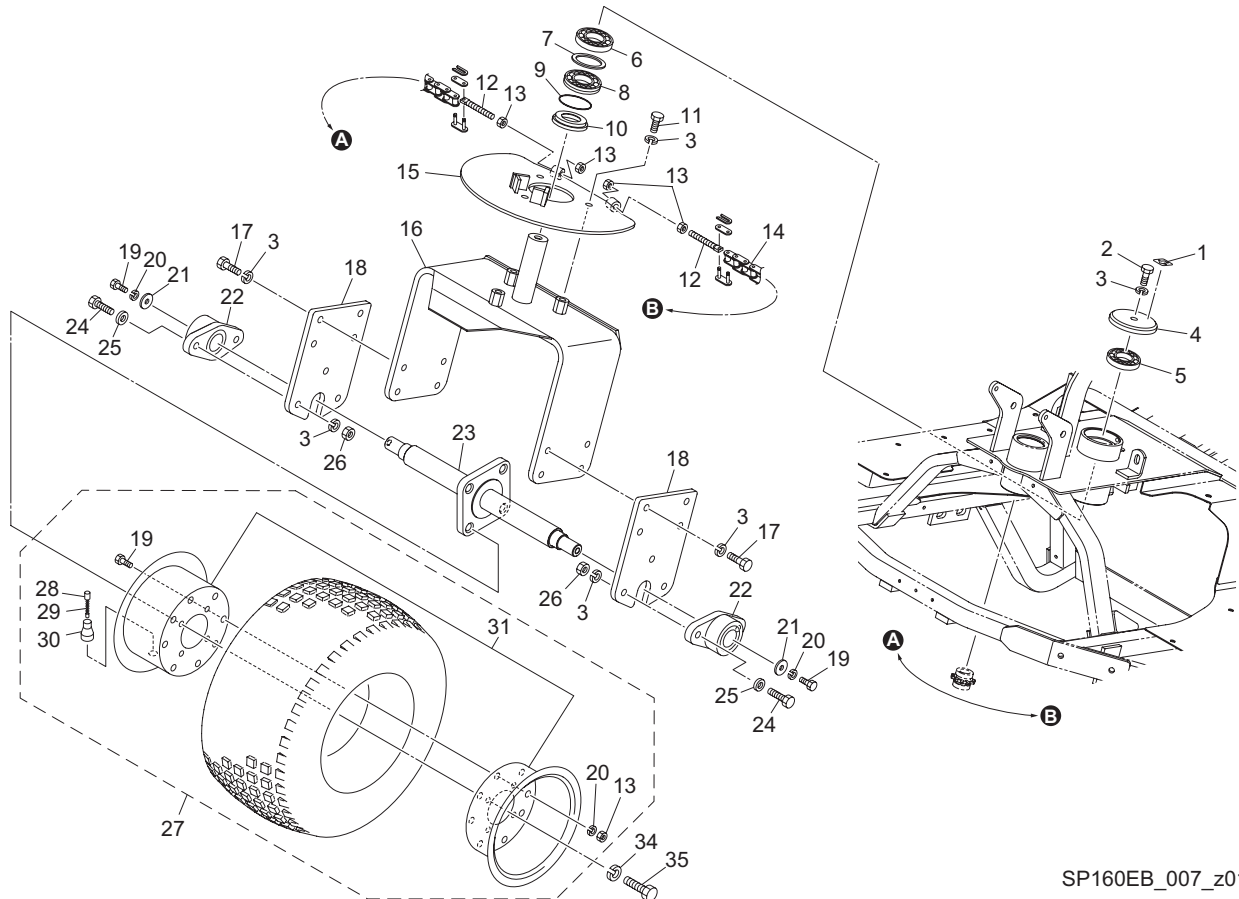

SP160EB_007_z01

Cat No.	Code No.	Part name	Qty	Remark	SN of application
7-31	K2081000050	WHEEL SET, 850SP-10	1		
7-32					
7-33					
7-34	K0200120002	WASHER, SPRING M12	4		
7-35	K0011120352	BOLT, HT P1.5 M12-35	4		

8. Rear wheel section

SP160EB

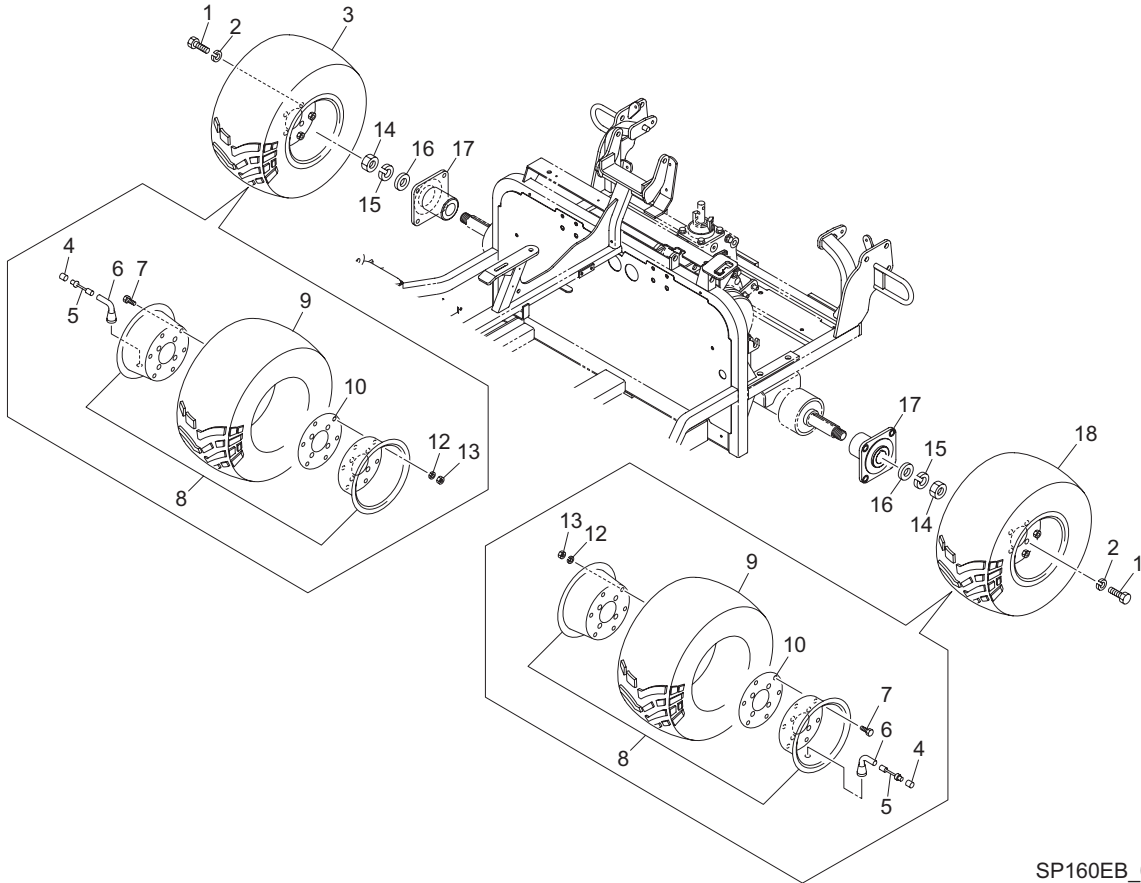

SP160EB_008_z02

Cat No.	Code No.	Part name	Qty	Remark	SN of application
8-1	K0011120352	BOLT, HT P1.5 M12-35	8		
8-2	K0200120002	WASHER, SPRING M12	8		
8-3	K2040000990	TIRE, C828-22*11-8AY-R	1		
8-4	K2093000010	CAP, VALVE	2		
8-5	K2092000020	CORE, VALVE NO.9000	2		
8-6	K2097000040	VALVE, RIM PVR70	2		
8-7	K0000080152	BOLT, M8-15	12		
8-8	K2090000580-SET	WHEEL, 8.50SP-8 SET	2		
8-9	K2041000530	TIRE, C828-22*11-8	2		
8-10	K2095000010	PACKING, F-8P-D	2		
8-11			2		
8-12	K0200080002	WASHER, SPRING M8	12		
8-13	K0100080002	NUT, M8	12		
8-14	K0160000042	NUT, SPECIAL P1.5 M20	2		
8-15	K0200200002	WASHER, SPRING M20	2		
8-16	K5000200002	WASHER, M20	2		
8-17	K7148000232	MOUNT, REAR WHEEL	2		
8-18	K2040001000	TIRE, C828-22*11-8AY-L	1		

9. Traveling section A

SP160EB

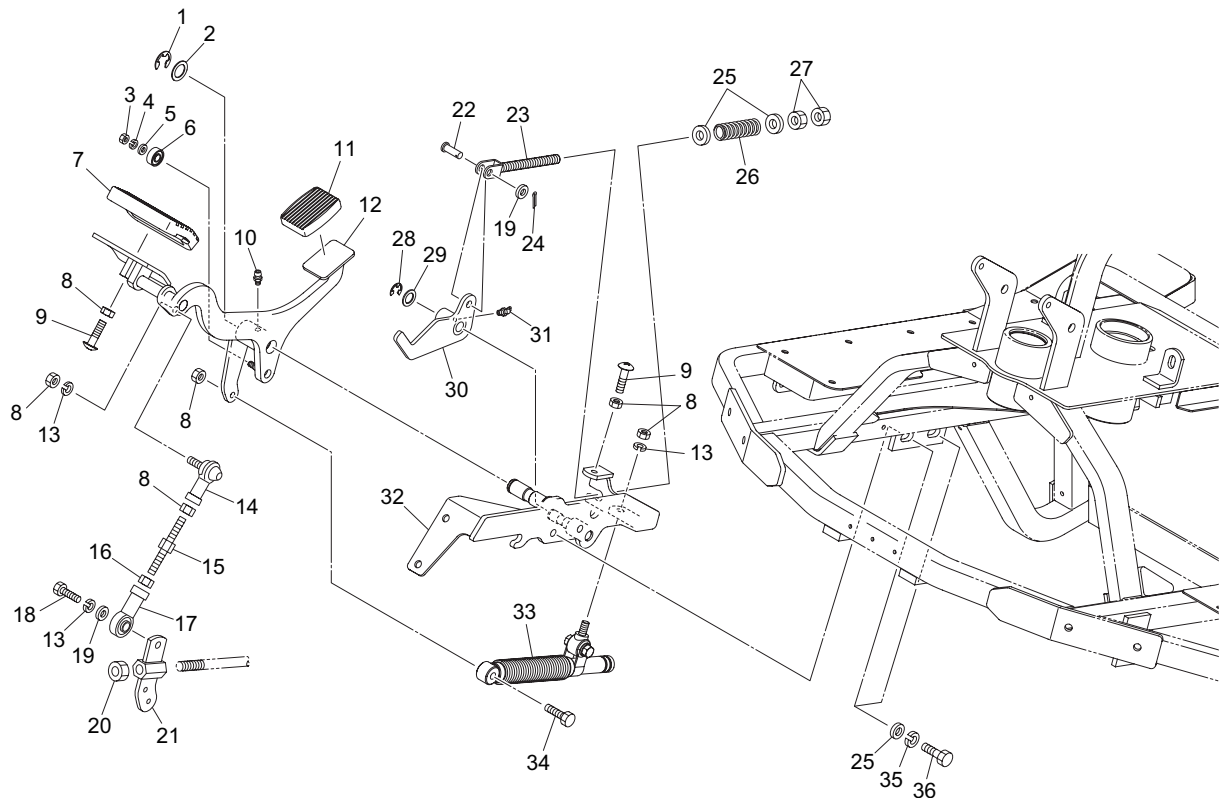

SP160EB_009_z00

Cat No.	Code No.	Part name	Qty	Remark	SN of application
9-1	K0400012002	RING, RETAINING E M12	1		
9-2	K5051016240	WASHER, C5191P 1-16-24	1		
9-3	K0100060002	NUT, M6	1		
9-4	K0200060002	WASHER, SPRING M6	1		
9-5	K5000060002	WASHER, M6	1		
9-6	K0608006070	BEARING, BALL SEAL 2RS 607	1		
9-7	K4050000050	RUBBER, FOR PEDAL 70100	1		
9-8	K0100080002	NUT, M8	6		
9-9	K0056080300	SCREW, SUS + TRUSS M8-30	2		
9-10	K1440000010	GREASE NIPPLE, STRAIGHT TYPE A	1		
9-11	K4050000020	RUBBER, FOR PEDAL 4560	1		
9-12	SP160EB0401ZD	PEDAL, TRAVELING	1		
9-13	K0200080002	WASHER, SPRING M8	3		
9-14	K1604080000	JOINT, SPHERICAL LHSA8	1		
9-15	K6084000122	SHAFT, ADJUSTING THREADED M8	1		
9-16	K0180080002	NUT, LEFT-HANDED M8	1		
9-17	K16010800L0	JOINT, SPHERICAL PHS8LA	1		
9-18	K0000080252	BOLT, M8-25	1		
9-19	K5000080002	WASHER, M8	2		
9-20	K0105100002	NUT, P1.25 M10-3	1		
9-21	SP160EB0406Z2	BRACKET	1		
9-22	K6031080222	PIN, FLAT HEAD HT M8-22	1		
9-23	K7303000232	ADJUSTER, SPRING	1		
9-24	K0300020202	PIN, COTTER M2-20	1		
9-25	K5000100002	WASHER, M10	4		
9-26	K1000000078	SPRING, COMPRESSION M3.5-17.5-60	1		
9-27	K0100100002	NUT, M10	2		
9-28	K0400009002	RING, RETAINING E M9	1		
9-29	K5011012202	WASHER, SPCC 1-12-20	1		
9-30	SP160E-0408Z2	LEVER, NEUTRAL	1		

9. Traveling section A

SP160EB

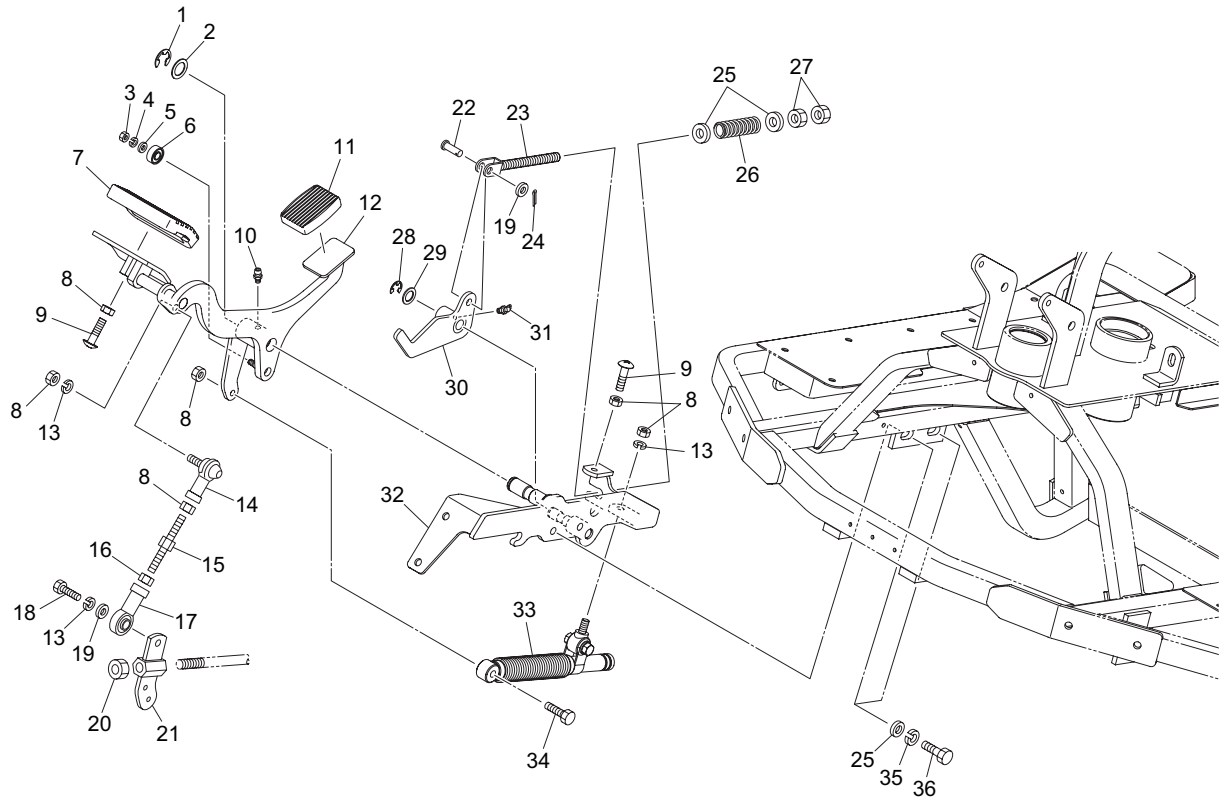

SP160EB_009_z00

Cat No.	Code No.	Part name	Qty	Remark	SN of application
9-31	K1440000020	GREASE NIPPLE, 90 DEG TYPE C	1		
9-32	SP160EB0402ZD	PLATE, FULCRUM TRAVELING PEDAL	1		
9-33	K3380000030	DAMPER	1		
9-34	K0000080302	BOLT, M8-30	1		
9-35	K0200100002	WASHER, SPRING M10	2		
9-36	K0000100202	BOLT, M10-20	2		

10. Traveling section B

SP160EB

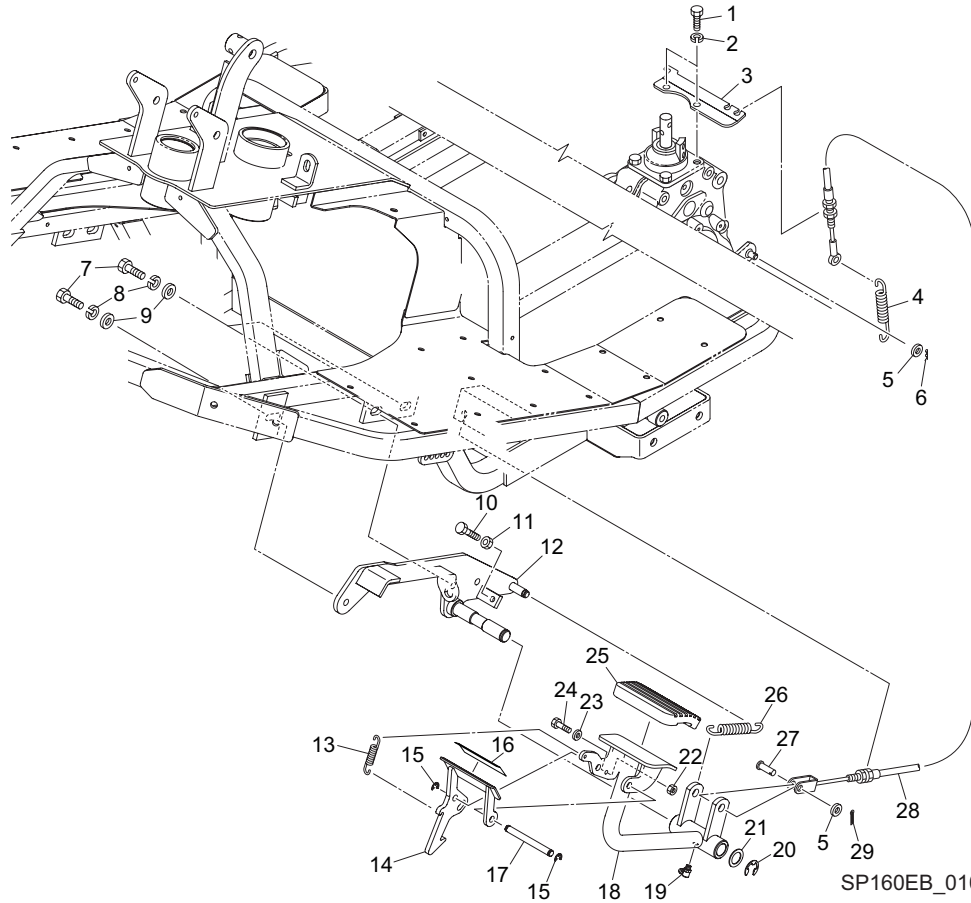

SP160EB_010_z00

Cat No.	Code No.	Part name	Qty	Remark	SN of application
10-1	K0000080252	BOLT, M8-25	2		
10-2	K0200080002	WASHER, SPRING M8	2		
10-3	SP160E-3406Z2	RECEIVER, WIRE	1		
10-4	K103000001D	SPRING, W/U HOOK M2.9-15-64.2	1		
10-5	K5000080002	WASHER, M8	2		
10-6	K0340800002	PIN, SNAP W/RETAINER M8	1		
10-7	K0000100202	BOLT, M10-20	3		
10-8	K0200100002	WASHER, SPRING M10	3		
10-9	K5000100002	WASHER, M10	3		
10-10	K0000080302	BOLT, M8-30	1		
10-11	K0100080002	NUT, M8	1		
10-12	SP160EB0405ZD	FULCRUM, BRAKE	1		
10-13	K1030000108	SPRING, W/U HOOK M1.2-9.4-35	1		
10-14	SP160EB0404ZD	HARDWARE, LOCKING PEDAL	1		
10-15	K0400006002	RING, RETAINING E M6	2		
10-16	SP160E-3412Z0	SHEET, NONSKID FOR PEDAL	1		
10-17	SP160E-3411Z2	SHAFT, 8-78	1		
10-18	SP160EB0403AD	PEDAL, BRAKE	1		
10-19	K1440000020	GREASE NIPPLE, 90 DEG TYPE C	1		
10-20	K0400012002	RING, RETAINING E M12	1		
10-21	K5051016240	WASHER, C5191P 1-16-24	1		
10-22	K0100060002	NUT, M6	1		
10-23	K5000060002	WASHER, M6	1		
10-24	K0000060202	BOLT, M6-20	1		
10-25	K4050000050	RUBBER, FOR PEDAL 70100	1		
10-26	K1030000048	SPRING, W/U HOOK M2-14-80	1		
10-27	K6031080222	PIN, FLAT HEAD HT M8-22	1		
10-28	K1120178000	WIRE, BRAKE 1780	1		
10-29	K0300020202	PIN, COTTER M2-20	1		

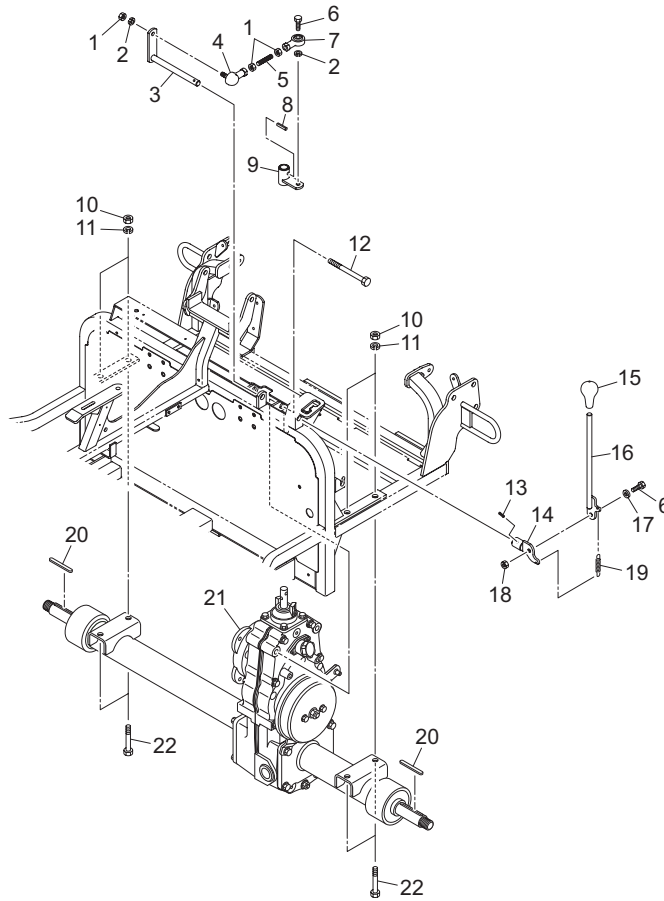

SP160EB_011_z00

Cat No.	Code No.	Part name	Qty	Remark	SN of application
11-1	K0100080002	NUT, M8	3		
11-2	K0200080002	WASHER, SPRING M8	2		
11-3	SP160E-0504Z2	LEVER, INTERMEDIATE	1		
11-4	K1604080000	JOINT, SPHERICAL LHS A8	1		
11-5	K0072000212	SHAFT, SCREWED M8-40	1		
11-6	K0000080202	BOLT, M8-20	2		
11-7	K1601080000	JOINT, SPHERICAL PHS8	1		
11-8	K0324060221	PIN, SPIRAL M6-22	1		
11-9	SP160E-0503ZD	LEVER, SHIFTING	1		
11-10	K0100100002	NUT, M10	4		
11-11	K0200100002	WASHER, SPRING M10	4		
11-12	K0003101102	BOLT, M10-110	1		
11-13	K0324040251	PIN, SPIRAL M4-25	1		
11-14	SP160E-3502ZD	FULCRUM, LEVER SHIFTING TRANSMISSION	1		
11-15	K1300000040	GRIP, RUBBER BLACK 9-35.5	1		
11-16	SP160EA0501ZD	LEVER, SHIFTING TRANSMISSION	1		
11-17	K5000080002	WASHER, M8	1		
11-18	K0144080002	NUT, W/F-RING M8	1		
11-19	K1030000068	SPRING, W/U HOOK M1.5-8.5-35.5	1		
11-20	K0500707630	KEY, BOTH ROUND M7-763	2		
11-21	K2700000310	TRANSMISSION, MC81MA01UNIT	1		
11-22	K0010100602	BOLT, HT M10-60	4		

12. Mission section B-1

SP160EB

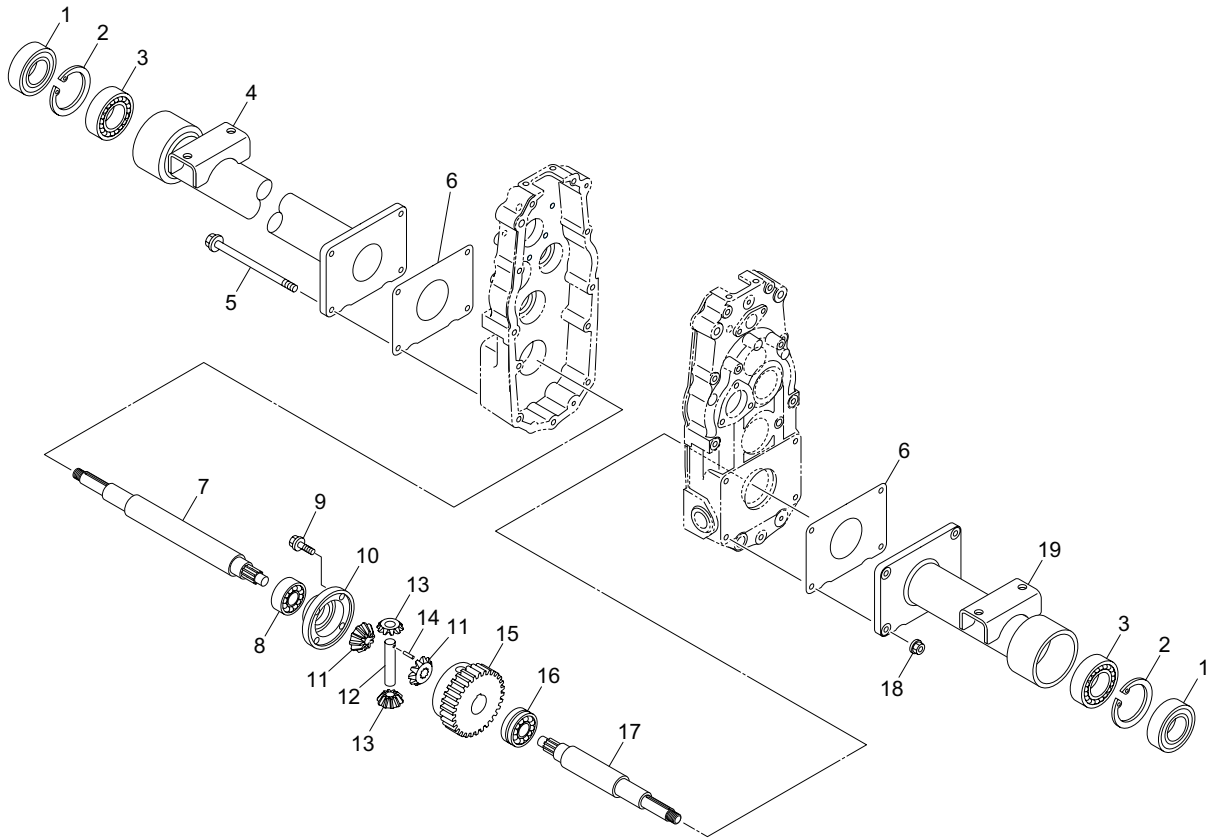

SP160EB_012_z00

Cat No.	Code No.	Part name	Qty	Remark	SN of application
12-1	P2104-419001	OIL SEAL, 357213	2		
12-2	K0402072001	RING, RETAINING R M72	2		
12-3	K0600062070	BEARING, BALL 6207	2		
12-4	P2310-622312	AXLE CASE (RH) COMP	1		
12-5	P0157-101600	BOLT, FLANGED M10	4		
12-6	P2153-407307	CASE, AXLE (PK)	2		
12-7	P2133-683718	SHAFT, G (RH)	1		
12-8	K0600062060	BEARING, BALL 6206 NR	1		
12-9	P2101-437600	BOLT, FRANGED	4		
12-10	P2114-403201	COVER, DIFF	1		
12-11	P2120-414301	SIDE GEAR, DIFF	2		
12-12	P2131-405004	SHAFT, DIFF LOCK	1		
12-13	P2120-401880	PINION, BEVEL	2		
12-14	K0320050281	PIN, SPRING M5-28	1		
12-15	P2129-642013	GEAR, L39	1		
12-16	P0501-620660	BEARING, BALL 6206 NR	1		
12-17	P2133-683619	SHAFT, G (LH)	1		
12-18	P2101-417901	NUT, FLANGED 10	4		
12-19	P2310-622213	AXLE CASE (LH) COMP	1		

13. Mission section B-2

SP160EB

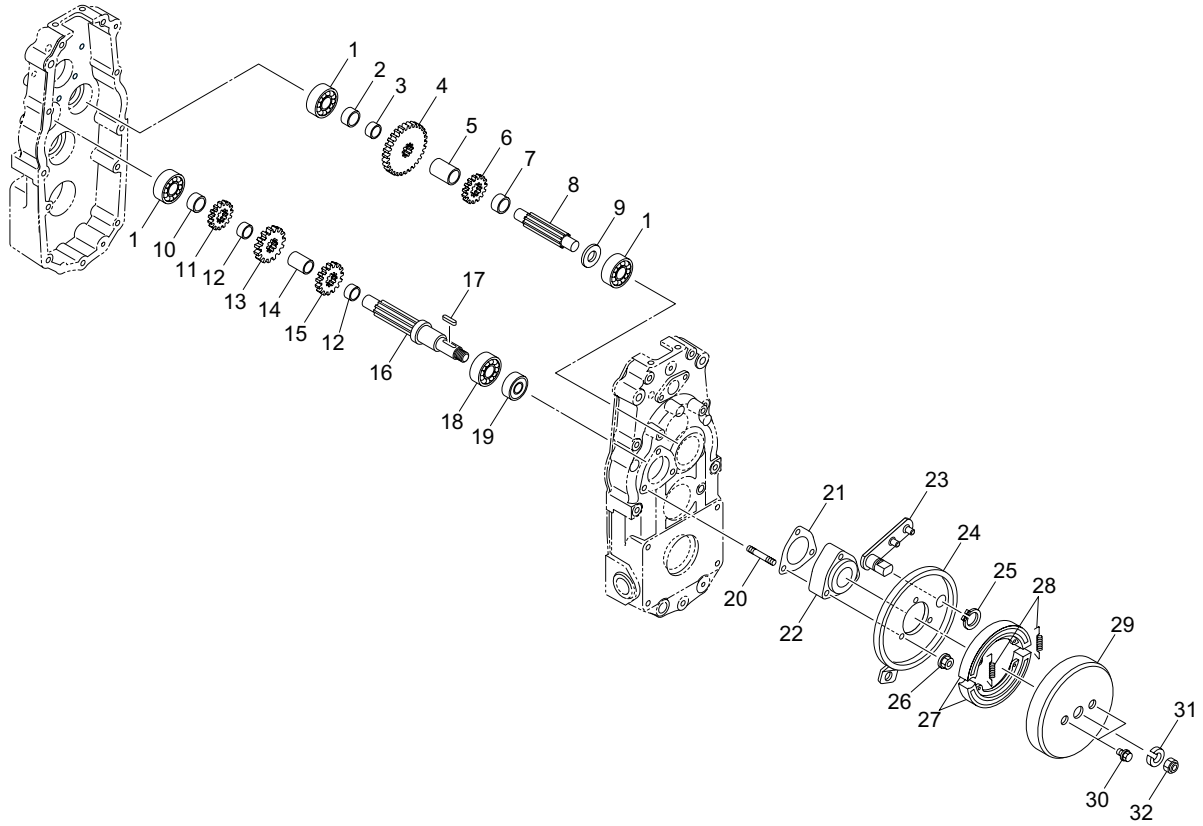

SP160EB_013_z00

Cat No.	Code No.	Part name	Qty	Remark	SN of application
13-1	K0600063030	BEARING, BALL 6303	3		
13-2	P2103-411907	COLLAR, 17257.5	1		
13-3	P2103-400105	COLLAR, 202510	1		
13-4	P2123-429702	GEAR, L32	1		
13-5	P2103-431002	COLLAR, 202527	1		
13-6	P2124-411207	GEAR, I14	1		
13-7	P2103-423003	COLLAR, 20257	1		
13-8	P2132-404402	SHAFT, C	1		
13-9	P0701-172000	WASHER	1		
13-10	P2103-408200	COLLAR, 172516.5	1		
13-11	P2123-429603	GEAR, K14	1		
13-12	P2103-412003	COLLAR, 202511.5	2		
13-13	P2122-411814	GEAR, T40	1		
13-14	P2103-411402	COLLAR, 202524	1		
13-15	P2122-407505	GEAR, F30	1		
13-16	P2133-403415	SHAFT, B	1		
13-17	P0480-050250	KEY, 5-525	1		
13-18	K0600062040	BEARING, BALL 6204	1		
13-19	P2104-400500	OIL SEAL, 20407	1		
13-20	P0177-080503	BOLT, STUD 8	3		
13-21	P2153-407000	BRAKE, PK	1		
13-22	P2114-401009	HOLDER, BK	1		
13-23	P2150-001205	LEVER COMP, BRAKE	1		
13-24	P2150-001106	COVER COMP, BRAKE	1		
13-25	K0401018001	RING, RETAINING S M18	1		
13-26	P2101-432506	NUT, FLANGED M8	3		
13-27	P2150-001304	SHOE, BRAKE	2		
13-28	P2150-001502	SPRING	2		
13-29	P2150-001700	DRAM, BRAKE	1		
13-30	P2105-400103	PLUG, 8	2		

13. Mission section B-2

SP160EB

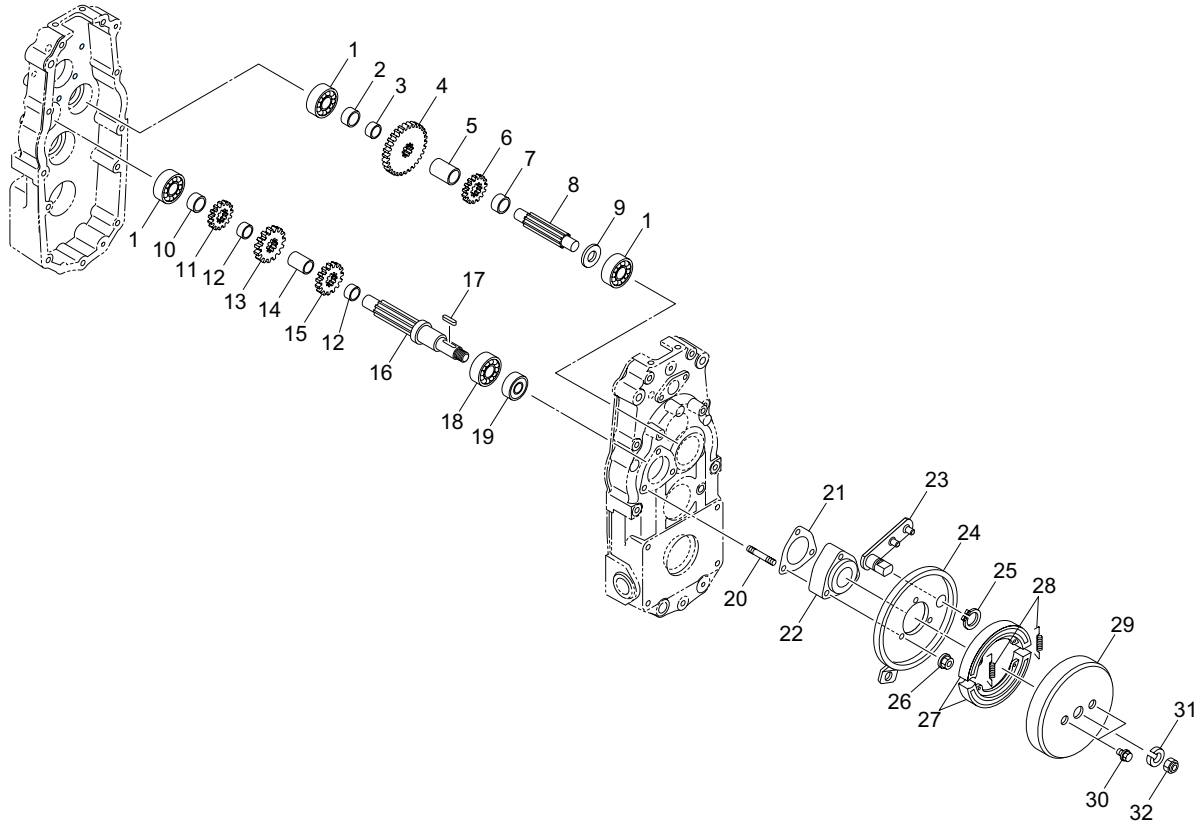

SP160EB_013_z00

Cat No.	Code No.	Part name	Qty	Remark	SN of application
13-31	P0410-140000	SPRING WASHER, M14	1		
13-32	P2101-411909	NUT, LOCKING 12	1		

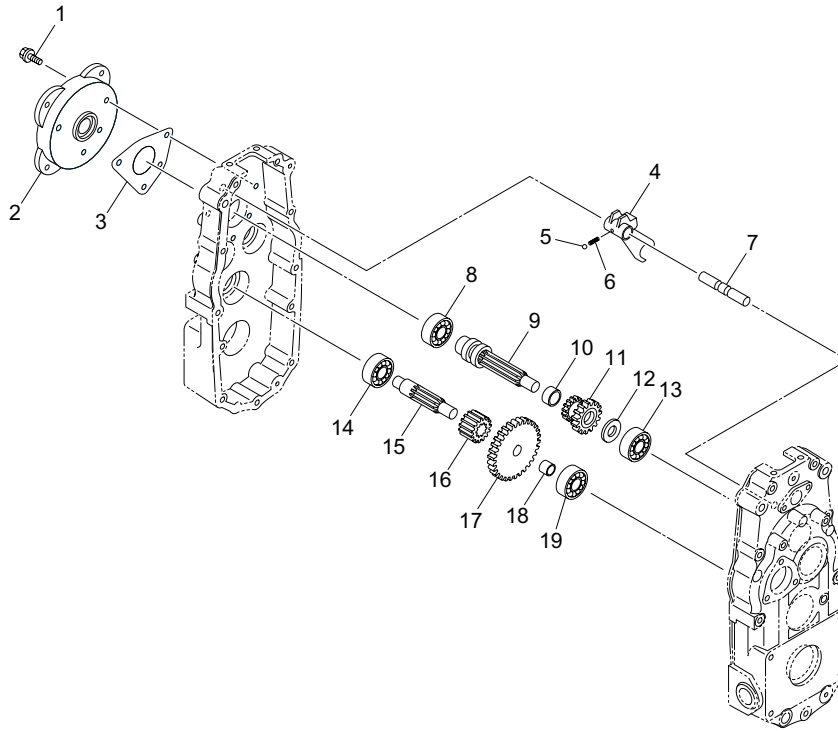

SP160EB_014_z00

Cat No.	Code No.	Part name	Qty	Remark	SN of application
14-1	P2101-430601	BOLT, FRANGED SEALED M8-20	4		
14-2	SP160E-3506Z2	MOUNT, MOTOR	1		
14-3	P2153-421213	SPACER, PK	1		
14-4	P2144-405503	SHIFTER, FORK BC	1		
14-5	P0650-050160	BALL, STEEL 5/16	1		
14-6	P2152-400200	SPRING, FOR FORK	1		
14-7	P2141-400512	SHIFTER SHAFT A	1		
14-8	P0501-690600	BEARING, BALL 6906	1		
14-9	P2330-357405	FIXTURE COMP, A	1		
14-10	P2103-423102	COLLAR, 202515.5	1		
14-11	P2122-467602	GEAR, AB19-28	1		
14-12	P0701-172000	WASHER	1		
14-13	K0600063030	BEARING, BALL 6303	1		
14-14	K0600062040	BEARING, BALL 6204	1		
14-15	P2132-407601	SHAFT, D	1		
14-16	P2123-421805	GEAR, K14	1		
14-17	P2124-411306	GEAR, J31	1		
14-18	P2103-403601	COLLAR, 20258	1		
14-19	K0600063040	BEARING, BALL 6304	1		

15. Mission section B-4

SP160EB

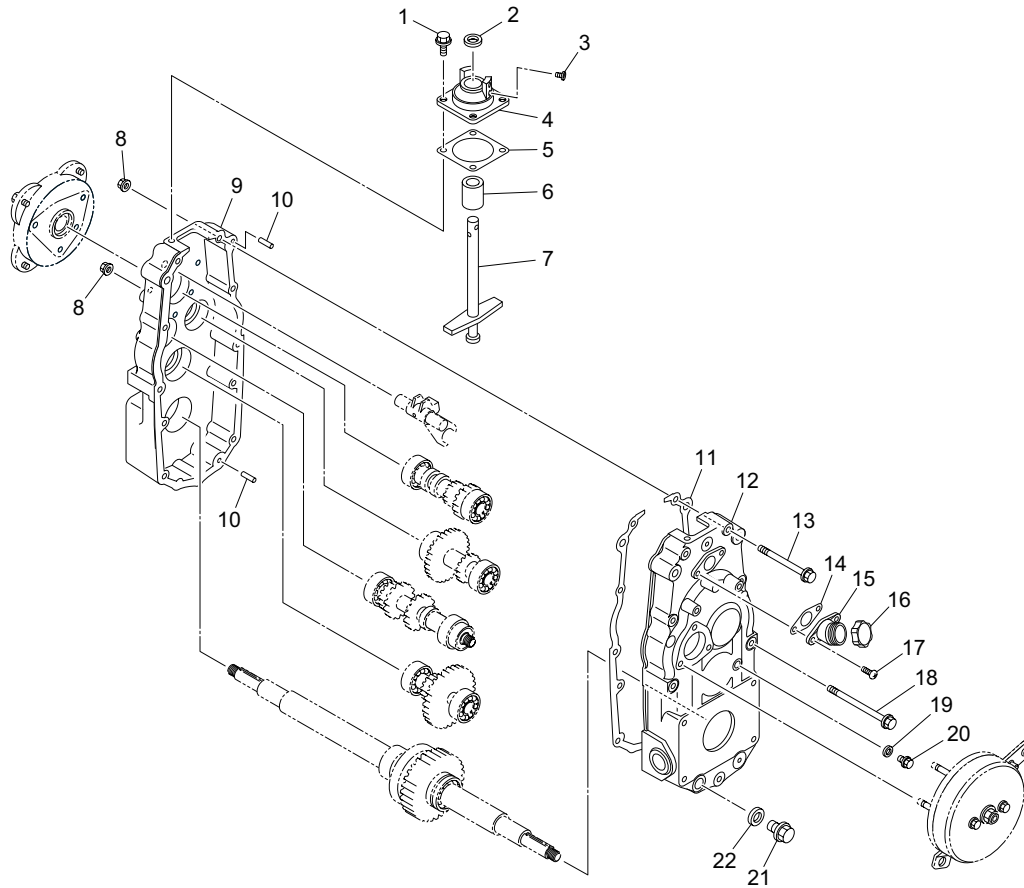

SP160EB_015_z00

Cat No.	Code No.	Part name	Qty	Remark	SN of application
15-1	P0157-080180	BOLT, FLANGED M8	4		
15-2	P2104-400104	OIL SEAL, 15244	1		
15-3	P2101-404501	SCREW, PAN HEAD 6-8	2		
15-4	P2144-601002	BRACKET, CH	1		
15-5	P2153-400111	BRACKET, PK CH	1		
15-6	P2103-408408	COLLAR, 152527	1		
15-7	P2340-406906	FIXTURE COMP, CH	1		
15-8	P2101-432506	NUT, FLANGED M8	7		
15-9	P2111-813234	CASE, (RH)	1		
15-10	P2155-401709	PIPE, KNOCK	2		
15-11	P2153-700509	CASE, PK	1		
15-12	P2111-802081	CASE, (LH)	1		
15-13	P0157-080900	BOLT, FLANGED M8	4		
15-14	P2153-404801	PORT, FILLING OIL (PK)	1		
15-15	P2157-401905	PORT, FILLING OIL	1		
15-16	P2105-404002	PLUG, G20	1		
15-17	P0210-060120	SCREW, PAN HEAD 6	2		
15-18	P0157-081150	BOLT, FLANGED M8	3		
15-19	P2105-400202	GASKET, 8	1		
15-20	P2105-400103	PLUG, 8	1		
15-21	P2105-400806	PLUG, 14	1		
15-22	P2105-400905	GASKET, 14	1		

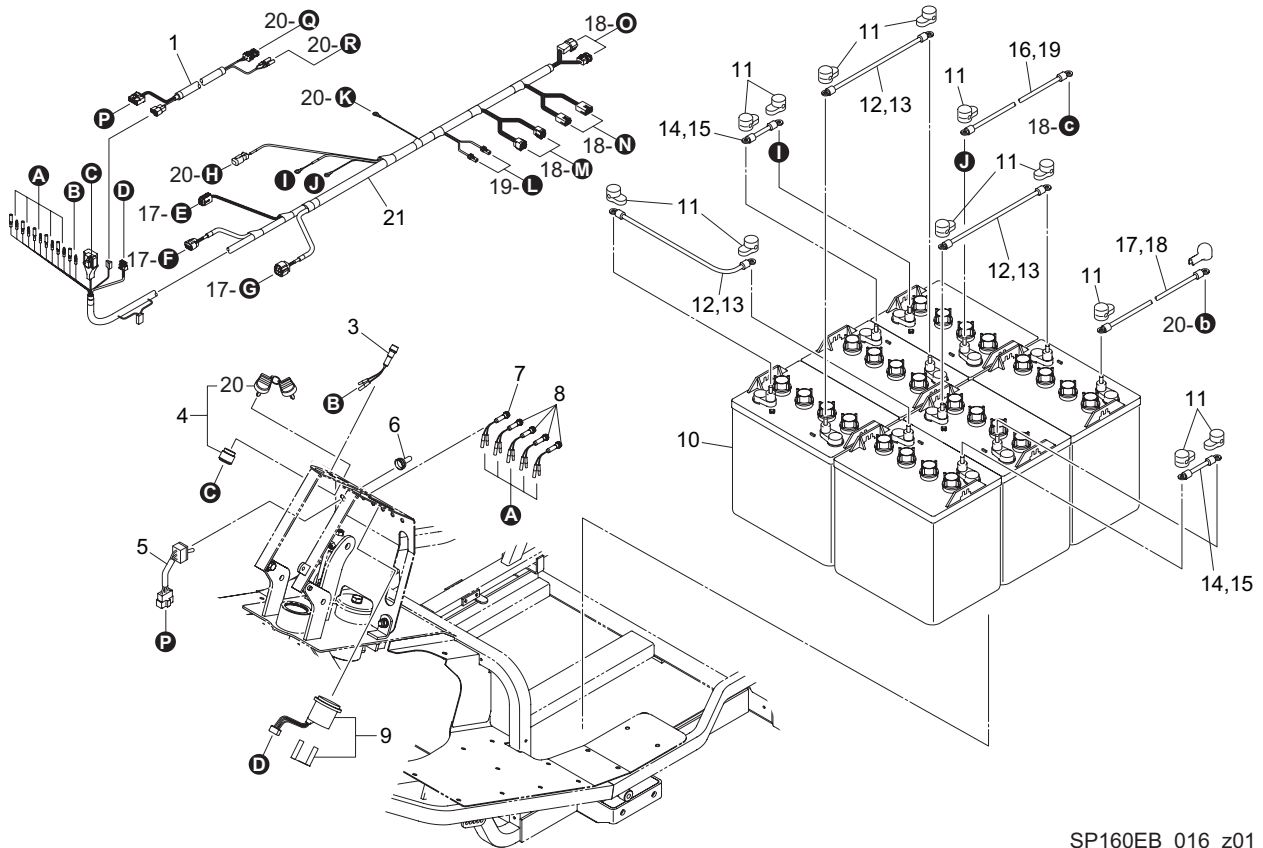

SP160EB_016_z01

Cat No.	Code No.	Part name	Qty	Remark	SN of application
16-1	SP160EB0630A0	HARNESS, ELECTORIC CYLINDER	1		
16-2					
16-3	SP160EA0605Z0	LAMP, PILOT RED	1		
16-4	K3660000050	SWITCH, MAIN	1		
16-5	K3662000130	SWITCH, TOGGLE WD131280	1		
16-6	K4031000330	CAP, RUBBER WD1811 BLACK	1		
16-7	SP160EB0602Z0	LAMP, LED ORANGE	1		
16-8	SP160EB0601Z0	LAMP, LED RED	4		
16-9	SP160E-0604Z0	METER, RESIDUAL CAPACITY OF BATTERY	1		
16-10	K3600000290	BATTERY, 8V US8VGHG-UTLXC3	6		
16-11	SP160E-3636Z0	COVER, TERMINAL (RED/BLACK)	6		
16-12	K3610000460	WIRE, BATTERY (+) 360	3		
16-13	K3194102900	TUBE, CORRUGATED, 10-290	3		
16-14	K3610000470	WIRE, BATTERY (+) 95	2		
16-15	K3194100250	TUBE, CORRUGATED, 10-25	2		
16-16	K3611000480	WIRE, TO EARTH 1020	1		
16-17	K3610000510	WIRE, BATTERY (+) 650	1		
16-18	K3194105600	TUBE, CORRUGATED, 10-560	1		
16-19	K3194109300	TUBE, CORRUGATED, 10-930	1		
16-20	K3660000050-1	KEY, MAIN SWITCH	1		
16-21	SP160EB0641A0	HARNESS, MAIN	1		

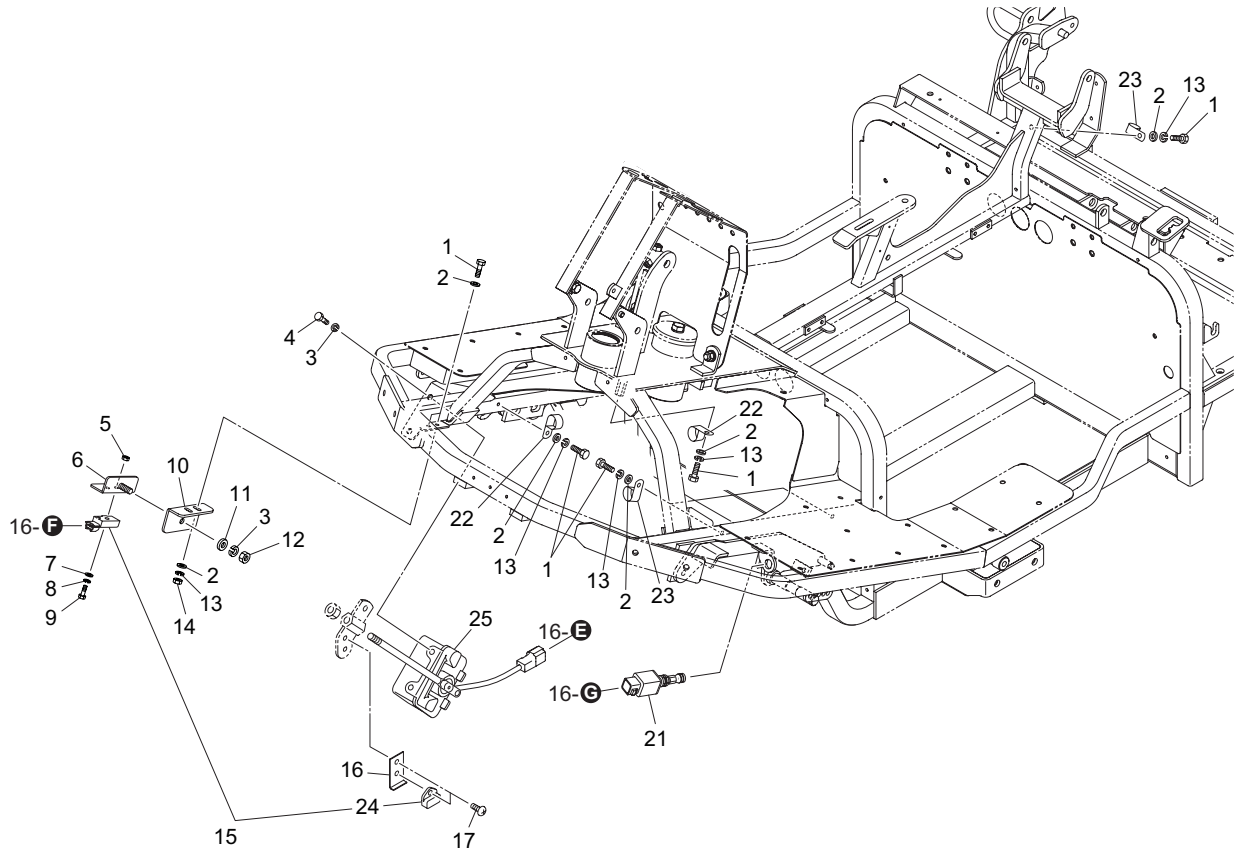

SP160EB_017_z02

Cat No.	Code No.	Part name	Qty	Remark	SN of application
17-1	K0000060152	BOLT, M6-15	7		
17-2	K5000060002	WASHER, M6	9		
17-3	K0200080002	WASHER, SPRING M8	3		
17-4	K0000080102	BOLT, M8-10	2		
17-5	K0100050002	NUT, M5	1		
17-6	SP160EB0627ZD	BRACKET, SENSOR	1		
17-7	K5000050002	WASHER, M5	1		
17-8	K0200050002	WASHER, SPRING M5	1		
17-9	K0000050202	BOLT, M5-20	1		
17-10	SP05---0603ZD	PLATE, POSITIONING SENSOR	1		
17-11	K5000080002	WASHER, M8	1		
17-12	K0100080002	NUT, M8	1		
17-13	K0200060002	WASHER, SPRING M6	7		
17-14	K0100060002	NUT, M6	2		
17-15	K3720000160	SWITCH, PROXIMITY NO V-OUT	1		
17-16	SP05---0605Z2	BRACKET, MAGNET	1		
17-17	K0048050102	SCREW, + ROUND HEAD W/SW M5-10	2		
17-18					
17-19					
17-20					
17-21	K3671000110	SWITCH, LIMIT 2 CIRCUIT NC	1		
17-22	K4270035060	CLIP, HARNESS 35 M6	2		
17-23	K4270010060	CLIP, HARNESS 10-M6	3		
17-24	K1510000110	MAGNET, W/PLASTIC BASE	1		
17-25	SP160EB0640Z0	POTENTIOMETER ASSY	1		

18. Electrical section C

SP160EB

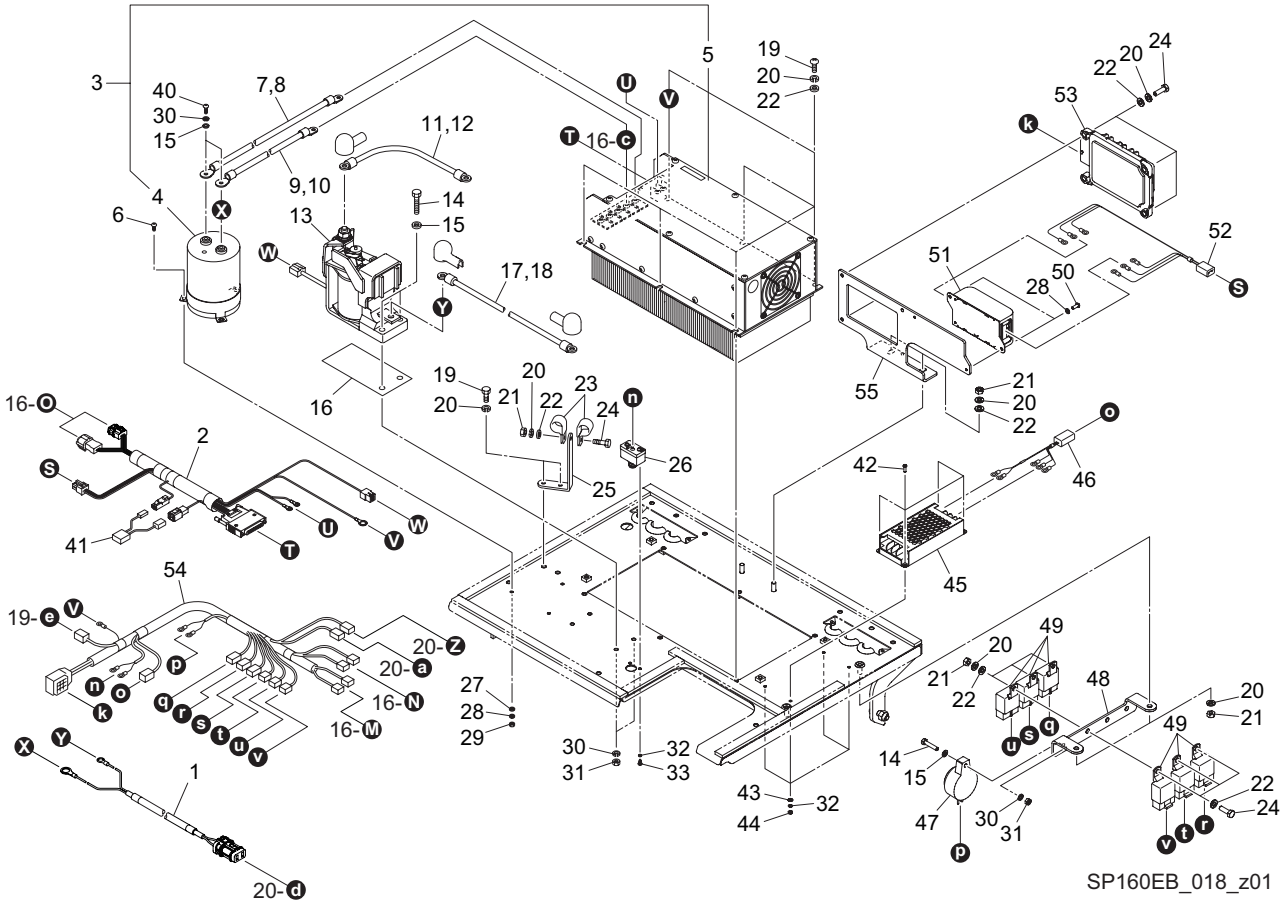

SP160EB_018_z01

Cat No.	Code No.	Part name	Qty	Remark	SN of application
18-1	SP160EB0626Z0	CONNECTOR, BATTERY CHARGING	1		
18-2	SP160EB0618A0	HARNESS COMP, DRIVER	1		
18-3	SP160EB0603A0	DRIVER COMP, SERVO	1		
18-4	SP160EA0660Z0	CONDENSER, ELECTROLYTIC	1		
18-5	SP160EB0604A0	SERVO DRIVERS	1		
18-6	K0042040152	SCREW, + ROUND HEAD M4-15	3		
18-7	K3620000870	WIRE, RED 250	1		
18-8	K3194101700	TUBE, CORRUGATED 10-170	1		
18-9	K3620000980	WIRE, BLACK 240	1		
18-10	K3194101600	TUBE, CORRUGATED 10-160	1		
18-11	K3620000990	WIRE, RED 300	1		
18-12	K3194102200	TUBE, CORRUGATED 10-220	1		
18-13	SP160E-0608Z0	CONTACTOR, RELAY	1		
18-14	K0000050252	BOLT, M5-25	3		
18-15	K5000050002	WASHER, M5	5		
18-16	SP160E-0630Z0	SHEET, INSULATION	1		
18-17	K3610000610	WIRE, BUTTERY PLUS 1020	1		
18-18	K3194109300	TUBE, CORRUGATED 10-930	1		
18-19	K0042060152	SCREW, + ROUND HEAD M5-40	8		
18-20	K0200060002	WASHER, SPRING M6	18		
18-21	K0100060002	NUT, M6	7		
18-22	K5000060002	WASHER, M6	19		
18-23	K4270015060	CLIP, HARNESS 15 M6	2		
18-24	K0000060202	BOLT, M6-20	8		
18-25	SP160EB0628ZD	CLAMPER, WIRE	1		
18-26	K3682000030	RELAY, OVERCURRENT OR-627-3.0A	1		
18-27	K5000040002	WASHER, M4	3		
18-28	K0200040002	WASHER, SPRING M4	5		
18-29	K0100040002	NUT, M4	3		
18-30	K0200050002	WASHER, SPRING M5	5		

18. Electrical section C

SP160EB

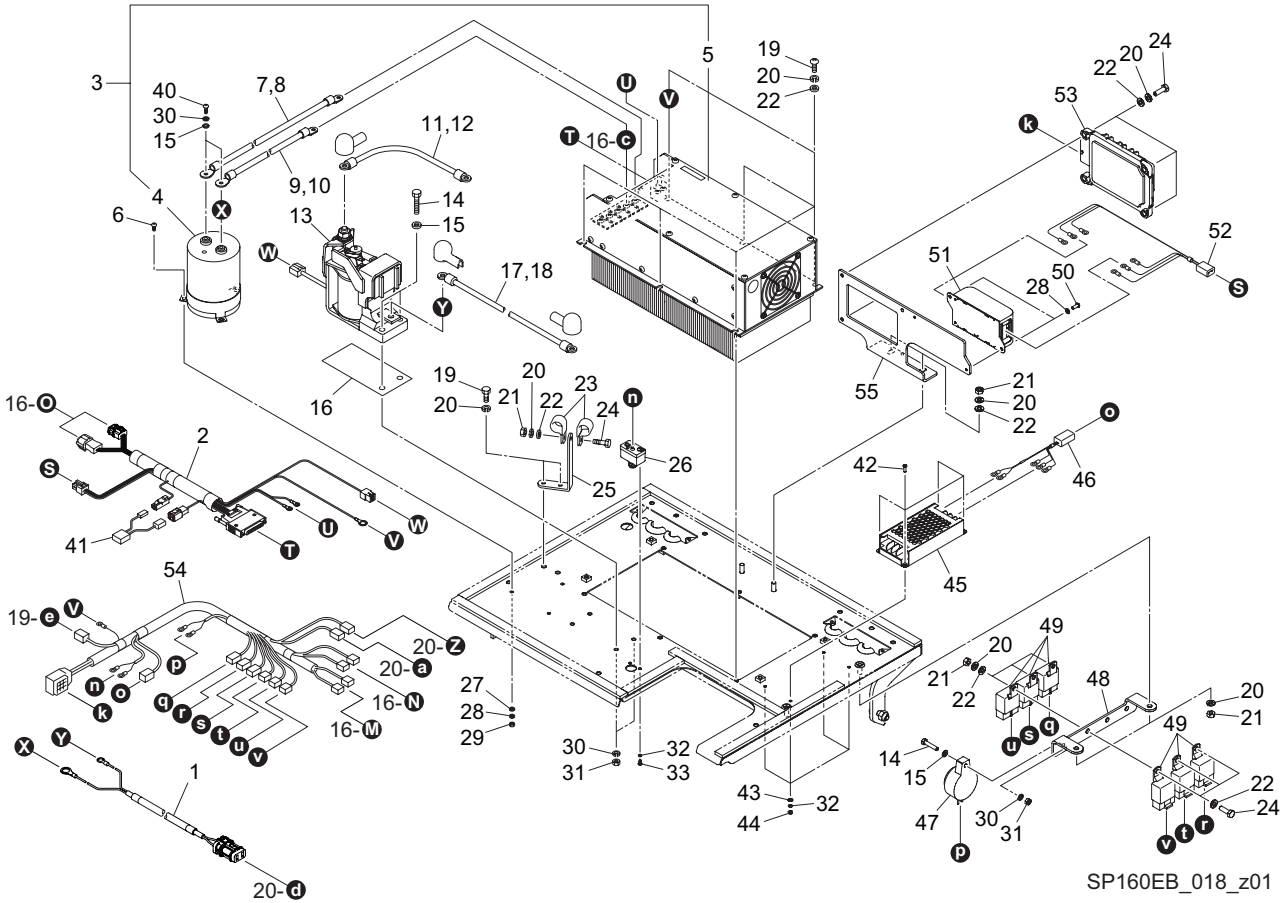

SP160EB_018_z01

Cat No.	Code No.	Part name	Qty	Remark	SN of application
18-31	K0100050002	NUT, M5	2		
18-32	K0200030002	WASHER, SPRING M3	1		
18-33	K0046030082	SCREW, + PAN HEAD M3-8	1		
18-34					
18-35					
18-36					
18-37					
18-38					
18-39					
18-40	K0000050122	BOLT, M5-12	2		
18-41	SP160EB0632Z0	CIRCUIT, VARIABLE RESISTANCE 5kΩ	1		
18-42	K0042030102	SCREW, + ROUND HEAD M3-10	4		
18-43	K5000030002	WASHER, M3	4		
18-44	K0100030002	NUT, M3	4		
18-45	SP160EB0644Z0	CONVERTER, DC-DC RSD-60L-24	1		
18-46	SP160EB0645Z0	CABLE, DC-DC CONVERTER RSD-60L-24	1		
18-47	SP160E-0611Z0	BUZZER, U-EBS24	1		
18-48	SP160EB0134ZD	BRACKET, RELAY	1		
18-49	SP160EB0643Z0	RELAY, CA1R-DC24V-N	6		
18-50	K0042040102	SCREW, + ROUND HEAD M4-10	2		
18-51	SP160EB0648Z0	CONVERTER, DC-DC STMGF30	1		
18-52	SP160EB0649Z0	CABLE, DC-DC CONVERTER STMGF30	1		
18-53	SP160EB0650Z0	BCU32 COMP	1		
18-54	SP160EB0642A0	HARNESS, ECU	1		
18-55	SP160EB0135ZD	BRACKET, ECU	1		

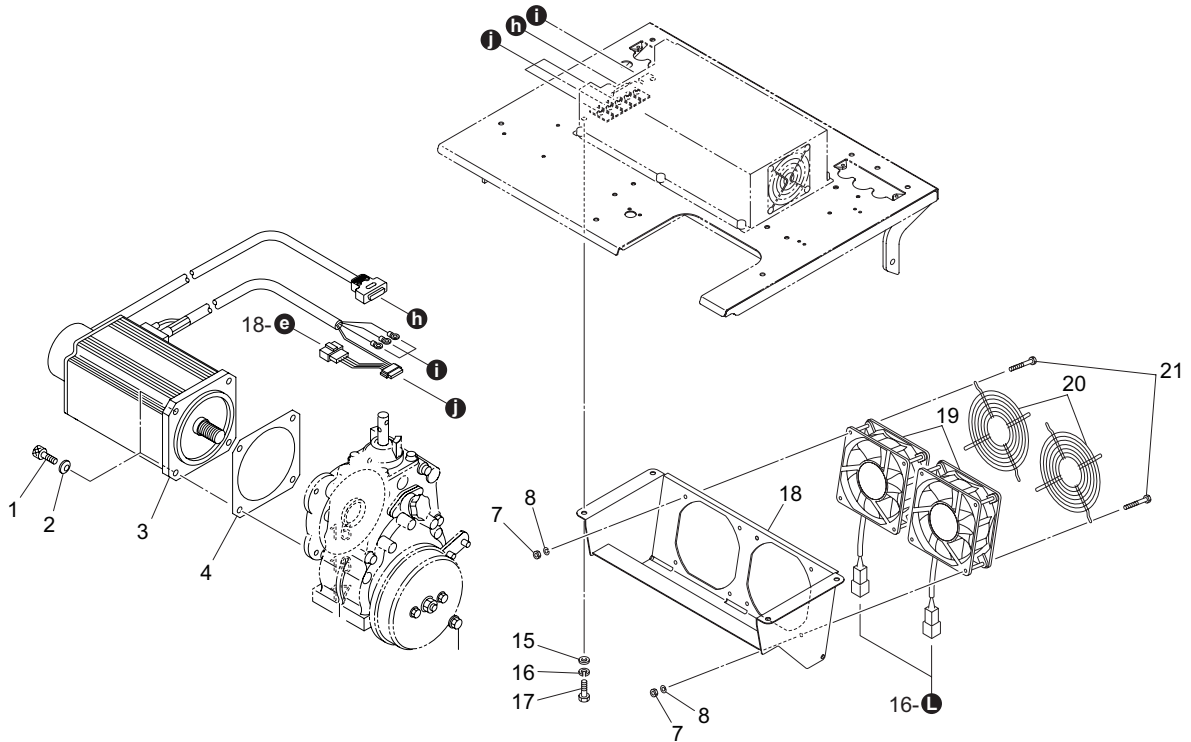

SP160EB_019_z01

Cat No.	Code No.	Part name	Qty	Remark	SN of application
19-1	K001A080251	BOLT, 13T W/HEX HOLE M8-25	4		
19-2	K0215080002	WASHER, DISK SPRING 2H M8	4		
19-3	SP160EB0610Z0	MOTOR COMP, SERVO	1		
19-4	SP160E-0627Z0	PACKING, MOTOR	1		
19-5					
19-6					
19-7	K0100040002	NUT, M4	8		
19-8	K0200040002	WASHER, SPRING M4	8		
19-9					
19-10					
19-11					
19-12					
19-13					
19-14					
19-15	K5000060002	WASHER, M6	4		
19-16	K0200060002	WASHER, SPRING M6	4		
19-17	K0000060152	BOLT, M6-15	4		
19-18	SP160EB0609ZD	DUCT, COOLING	1		
19-19	SP160EB0607Z0	FAN, COMP, COOLING	2		
19-20	SP160EB0608Z0	GUARD, FAN	2		
19-21	K0000040452	BOLT, M4-45	8		

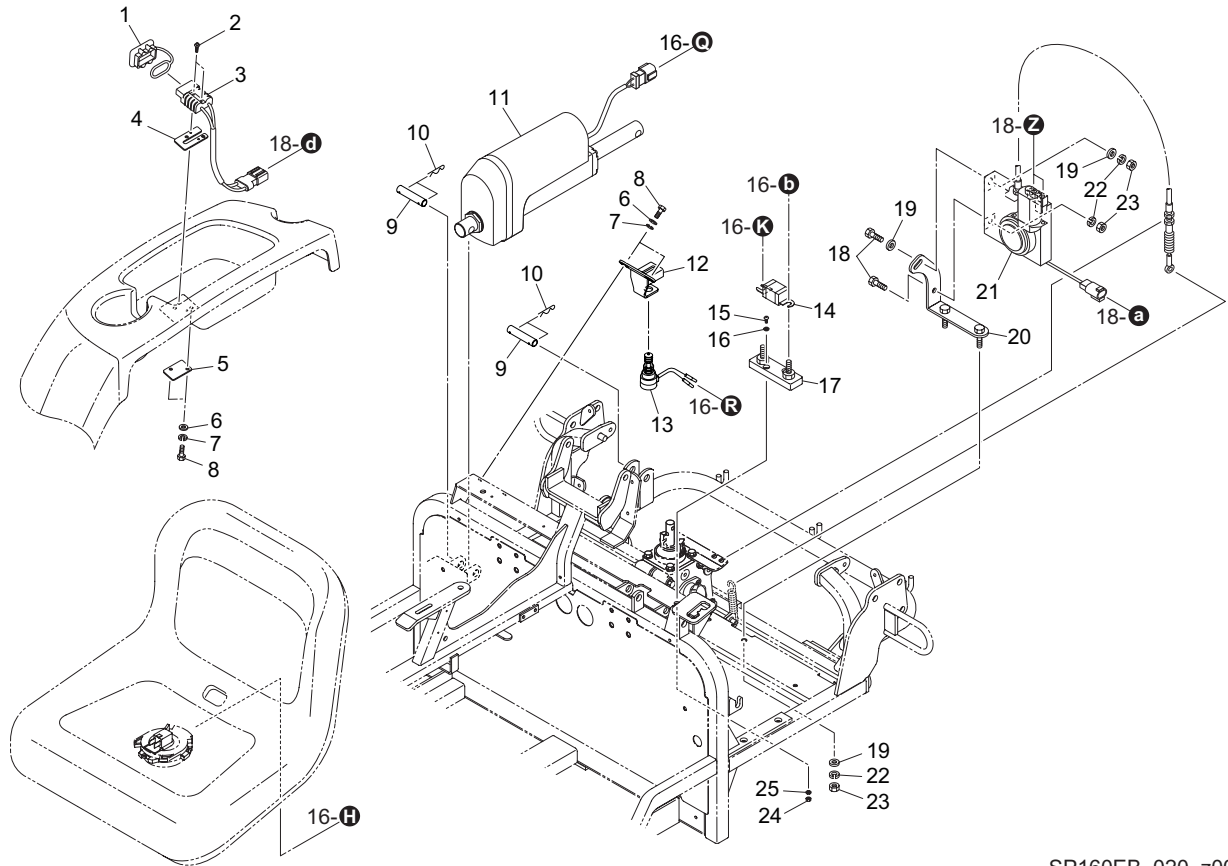

SP160EB_020_z00

Cat No.	Code No.	Part name	Qty	Remark	SN of application
20-1	SP160EB0621Z0	COVER, DUST	1		
20-2	K0044030202	SCREW, + ROUND HEAD W/SW M3-20	2		
20-3	SP160EB0614Z0	WIRE, FOR CHARGING	1		
20-4	SP160EB0622ZR	BRACKET, CHARGING CONNECTOR	1		
20-5	SP160EB0623Z2	PLATE, MOUNTING CHARGING CONNECTOR	1		
20-6	K5000060002	WASHER, M6	4		
20-7	K0200060002	WASHER, SPRING M6	4		
20-8	K0000060152	BOLT, M6-15	4		
20-9	SP160EB0615Z0	PIN, SUS M12.7-47	2		
20-10	K0361000008	PIN, SNAP KS M10	4		
20-11	SP160EB0625Z0	CYLINDER COMP, ELECTRIC LA36	1		
20-12	SP160EB0616ZD	BRACKET, SAFETY SWITCH	1		
20-13	K3671000080	SWITCH, SAFETY	1		
20-14	K3631000150	FUSE, 325A BF TYPE	1		
20-15	K0042040202	SCREW, + ROUND HEAD M4-20	2		
20-16	K5000040002	WASHER, M4	2		
20-17	K3630000100	FUSE BLOCK, 1P	1		
20-18	K0000080252	BOLT, M8-25	2		
20-19	K5000080002	WASHER, M8	4		
20-20	SP160EB0612ZD	BRACKET, SAFETY DEVICE	1		
20-21	SP160E-3637Z0	SAFETY DEVICE	1		
20-22	K0200080002	WASHER, SPRING M8	4		
20-23	K0100080002	NUT, M8	4		
20-24	K0100040002	NUT, M4	2		
20-25	K0200040002	WASHER, SPRING M4	2		

21. Rake section A

SP160EB

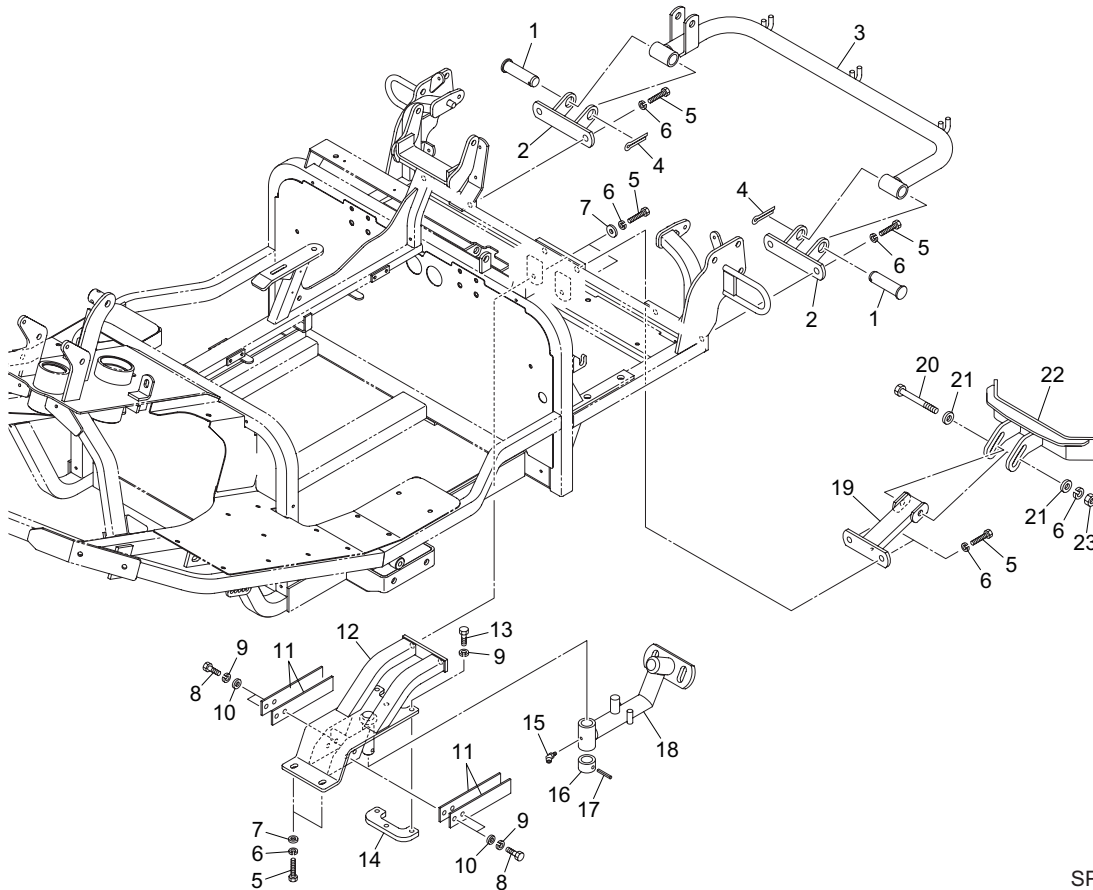

SP160EB_021_z00

Cat No.	Code No.	Part name	Qty	Remark	SN of application
21-1	K6031200702	PIN, FLAT HEAD HT M20-70	2		
21-2	SP160E-0701ZD	FULCRUM, RAKE HANGING ARM	2		
21-3	SP160EB0701ZD	ARM, HANGING RAKE	1		
21-4	K0300040502	PIN, COTTER M4-50	2		
21-5	K0000100202	BOLT, M10-20	10		
21-6	K0200100002	WASHER, SPRING M10	11		
21-7	K5000100002	WASHER, M10	4		
21-8	K0000080202	BOLT, M8-20	4		
21-9	K0200080002	WASHER, SPRING M8	7		
21-10	K5000080002	WASHER, M8	4		
21-11	K1090000110	SPRING, PLATE M2-40200	4		
21-12	SP160EB0702ZD	BRACKET, RAKE	1		
21-13	K0000080152	BOLT, M8-15	3		
21-14	SP160EA0711ZD	PLATE, 60 STOPPER	1		
21-15	K1440000030	GREASE NIPPLE, 67.5 DEG TYPE B	1		
21-16	K6215000212	COLLAR, STKM W/HOLE M20-30-17	1		
21-17	K0324060321	PIN, SPIRAL M6-32	1		
21-18	SP160EA0710AD	PIPE, FULCRUM RAKE	1		
21-19	SP160EA0701ZD	STAY, FIXING RAKE	1		
21-20	K0000100802	BOLT, M10-80	1		
21-21	K5073210262	WASHER, SPHC 3.2-10-26	2		
21-22	SP05---0725ZD	FIXTURE, RAKE	1		
21-23	K0100100002	NUT, M10	1		

22. Rake section B

SP160EB

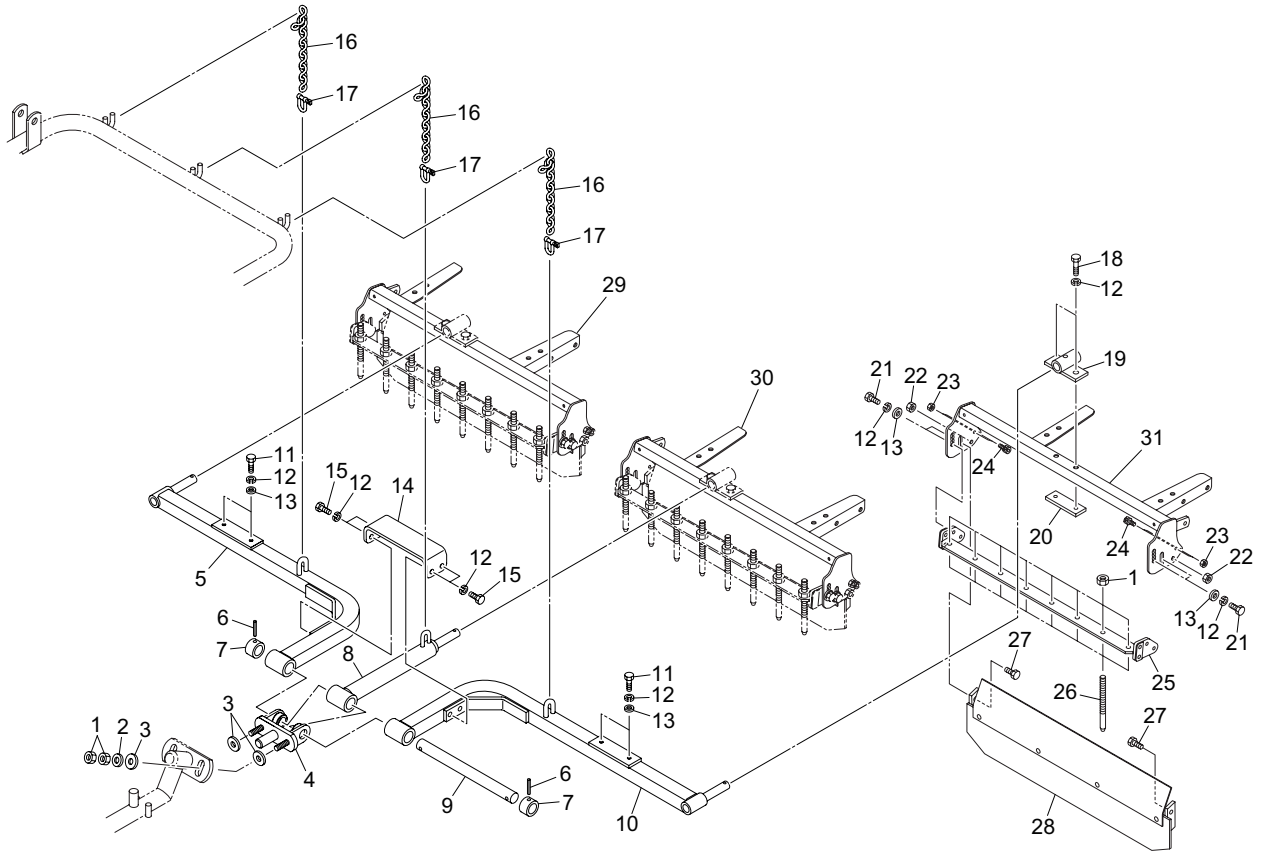

SP160EB_022_z00

Cat No.	Code No.	Part name	Qty	Remark	SN of application
22-1	K0100100002	NUT, M10	28		
22-2	K5000100002	WASHER, M10	2		
22-3	K5051010260	WASHER, C5191P 1-10-26	4		
22-4	SP05---0729AD	FULCRUM, SWINGING RAKE	1		
22-5	SP05---0732ZD	PIPE, RAKE (RH)	1		
22-6	K0324060321	PIN, SPIRAL M6-32	2		
22-7	K6215000212	COLLAR, STKM W/HOLE M20-30-17	2		
22-8	SP05---0733ZD	PIPE, RAKE (MIDDLE)	1		
22-9	SP05---0730Z0	SHAFT, RAKE M20-194	1		
22-10	SP05---0731ZD	PIPE, RAKE (LH)	1		
22-11	K0000080202	BOLT, M8-20	4		
22-12	K0200080002	WASHER, SPRING M8	26		
22-13	K5000080002	WASHER, M8	16		
22-14	SP05---0707ZD	FITTING, U-SHAPED 160	1		
22-15	K0010080152	BOLT, HT M8-15	4		
22-16	K4535000022	CHAINS, CROSS LINK B6-8	3		
22-17	K0410800002	SHACKLES, M8	3		
22-18	K0010080402	BOLT, HT M8-40	6		
22-19	SP05---0711AD	BRACKET, MOUNTING RAKE	3		
22-20	K514200040D	PLATE, 6 W/ 2-M8 2550	3		
22-21	K0000080152	BOLT, M8-15	12		
22-22	K0100080002	NUT, M8	6		
22-23	K0100060002	NUT, M6	12		
22-24	K0060060120	BOLT, SUS W/HEX HOLE M6-12	12		
22-25	SP05---0716ZD	BRACKET, FORK	3		
22-26	K6175000218	BAR, THREADED FORK PRONG	24		
22-27	K0010080202	BOLT, HT M8-20	6		
22-28	SP05---0717AD	RUNNERS	3		
22-29	SP05---0714ZD	FRAME, RAKE (RH)	1		
22-30	SP05---0715ZD	FRAME, RAKE (CENTER)	1		

22. Rake section B

SP160EB

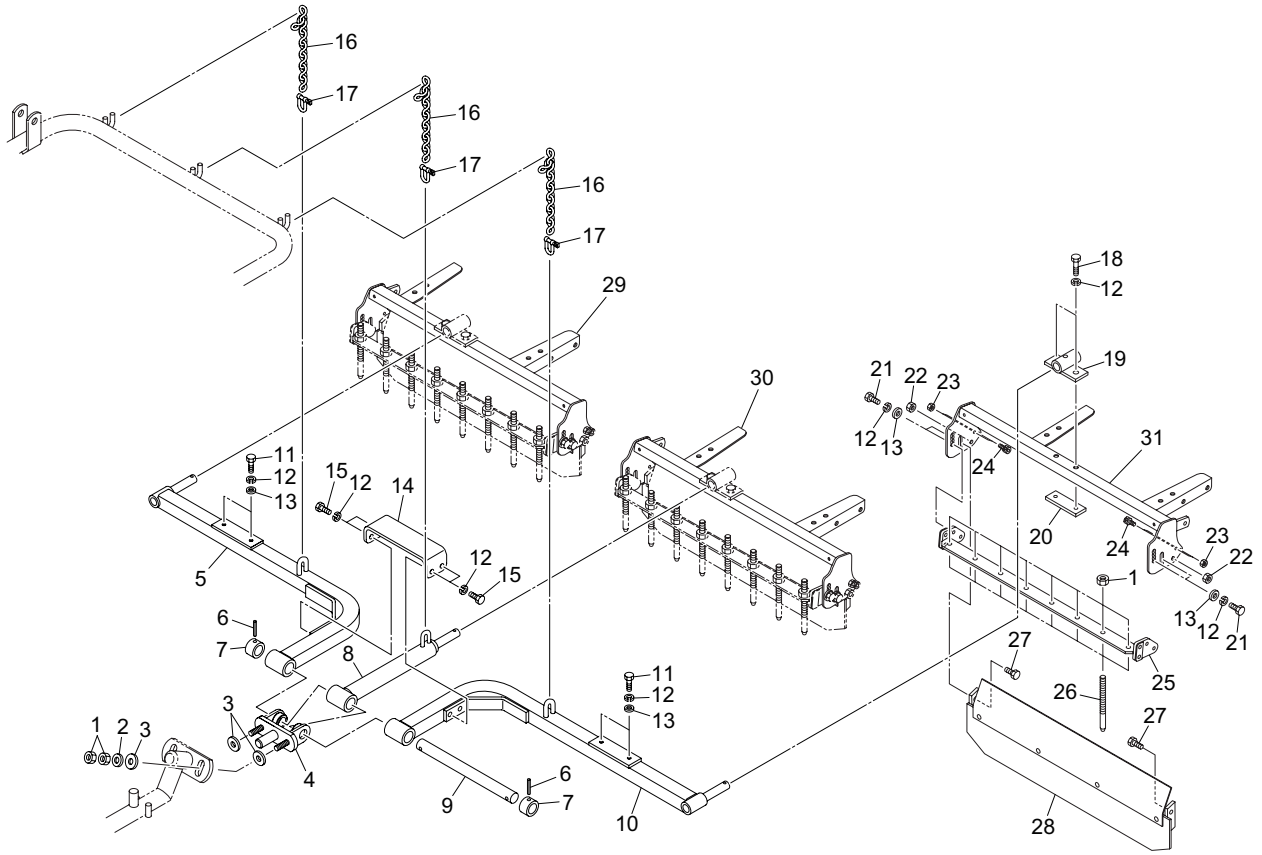

SP160EB_022_z00

Cat No.	Code No.	Part name	Qty	Remark	SN of application
22-31	SP05---0713ZD	FRAME, RAKE (LH)	1		

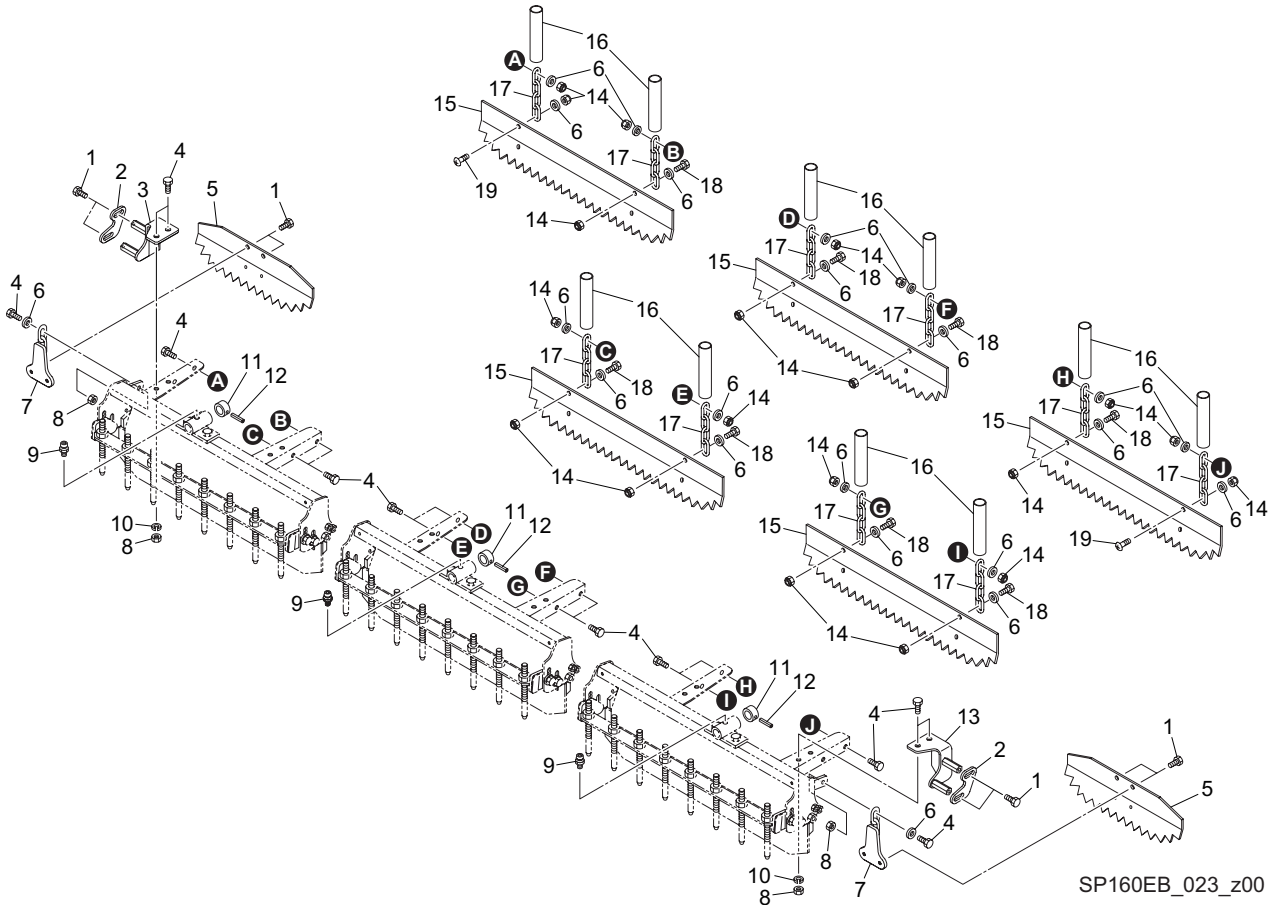

SP160EB_023_z00

Cat No.	Code No.	Part name	Qty	Remark	SN of application
23-1	K0000080152	BOLT, M8-15	8		
23-2	SP05---0721ZD	PLATE, STOPPER	2		
23-3	SP05---0719ZD	GUIDE, SIDE SMOOTHER (RH)	1		
23-4	K0000080202	BOLT, M8-20	16		
23-5	SP05---0723AD	PLATE, SIDE SMOOTHER 20-15 DEG	2		
23-6	K5000080002	WASHER, M8	22		
23-7	SP05---0720ZD	BRACKET, SIDE SMOOTHER	2		
23-8	K0100080002	NUT, M8	6		
23-9	K1440000010	GREASE NIPPLE, STRAIGHT TYPE A	3		
23-10	K0200080002	WASHER, SPRING M8	4		
23-11	K6215000222	COLLAR, STKM W/HOLE M16-25-13	3		
23-12	K0320050251	PIN, SPRING M5-25	3		
23-13	SP05---0718ZD	GUIDE, SIDE SMOOTHER (LH)	1		
23-14	K0144080002	NUT, W/F-RING M8	20		
23-15	SP05---0722ZD	PLATE, SMOOTHER 20-15 DEG	5		
23-16	K3172200800	HOSE, VINYL 19*23-80	10		
23-17	K4532000012	CHAINS, GENERAL USE 4.8-4	10		
23-18	K0000080252	BOLT, M8-25	8		
23-19	K0056080300	SCREW, SUS + TRUSS M8-30	2		

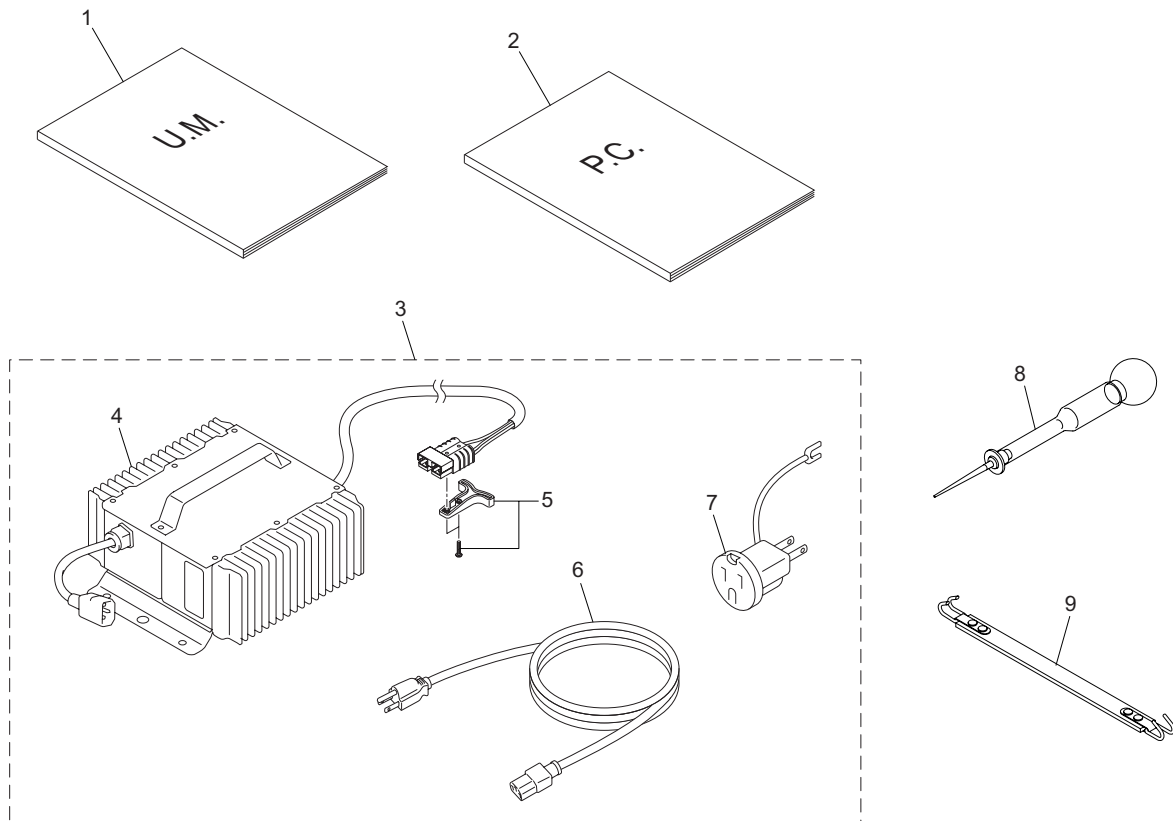

SP160EB_024_z01

Cat No.	Code No.	Part name	Qty	Remark	SN of application
24b-1	750103-129-A	OWNERS OPERATING MANUAL, SP160EB	1		
24b-2	750103-129-B	PARTS CATALOG, SP160EB	1		
24-3	SP160EB1702Z0	BATTERY CHARGER COMP, DQ48 (100V)	1		
24-4	SP160EB1703Z0	BATTERY CHARGER, DQ48-18	1		
24-5	SP160EB1704Z0	HANDLE, SB50	1		
24-6	SP160EB1705Z0	CABLE, AC 100V FOR CHARGER	1		
24-7	SP160EB1706Z0	ADAPTER, CONVERTING 3P-2P	1		
24-8	K3602000010	GRAVIMETER, BATTERY	1		
24-9	SP160E-0901Z0	HANDLE, BATTERY	1		

25. Front blade section

SP160EB

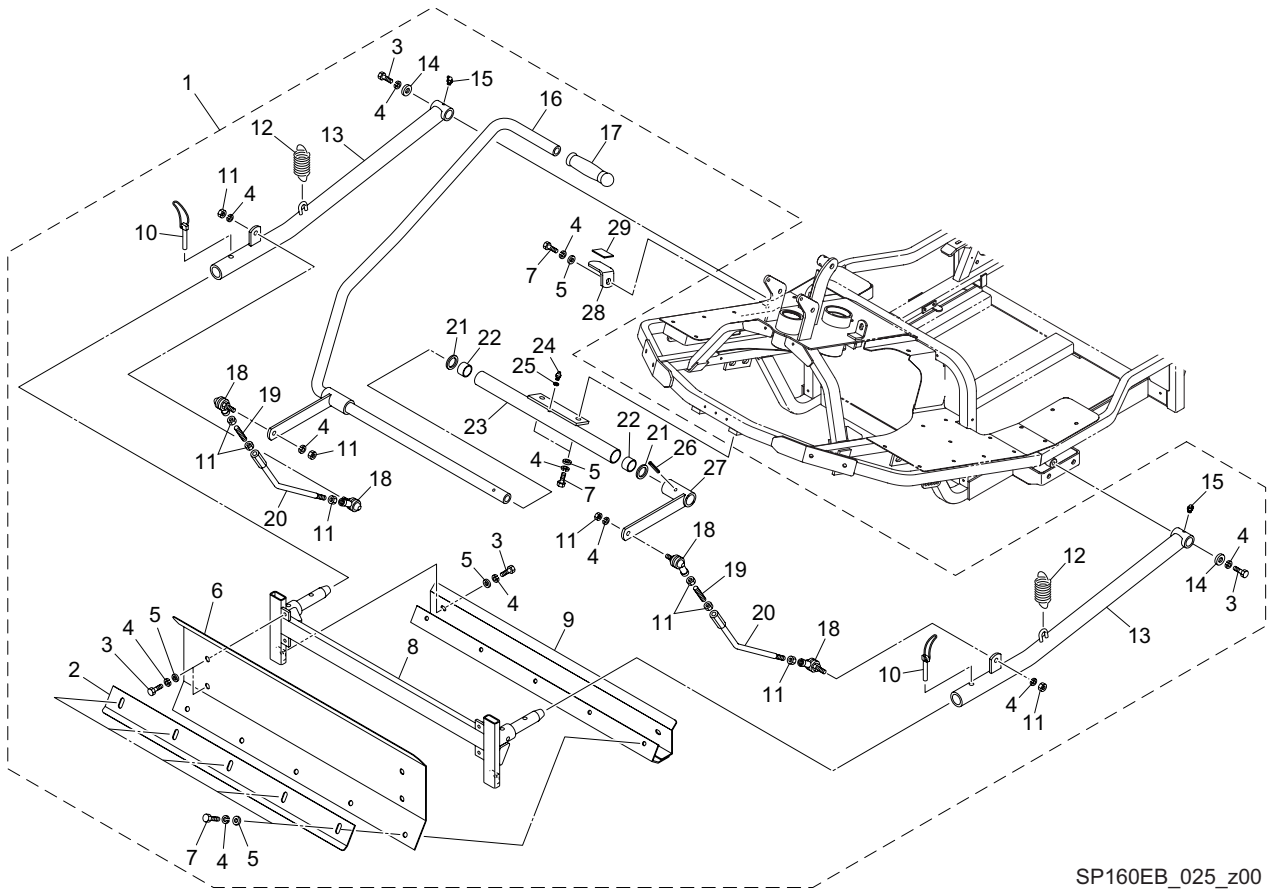

SP160EB_025_z00

Cat No.	Code No.	Part name	Qty	Remark	SN of application
25-1	SP160EA0820Z0	FRONT BLADE ASSY	1	option	
25-2	SP160E-3806ZD	BOARD, DOZER (SMALL)	1		
25-3	K0000100202	BOLT, M10-20	8		
25-4	K0200100002	WASHER, SPRING M10	20		
25-5	K5000100002	WASHER, M10	14		
25-6	SP160E-3804ZD	BOARD, DOZER (LARGE)	1		
25-7	K0000100252	BOLT, M10-25	8		
25-8	SP160EA0811ZD	FRAME, DOZER	1		
25-9	SP160E-3802ZD	PLATE, SUPPORTING DOZER BOARD	1		
25-10	K0450000028	PIN, DELTA M9	2		
25-11	K0100100002	NUT, M10	10		
25-12	K103000026D	SPRING, W/U HOOK M2.9-38-95	2		
25-13	SP160EA0810ZD	ARM, DOZER	2		
25-14	K5073210352	WASHER, SPHC 3.2-10-35	2		
25-15	K1440000020	GREASE NIPPLE, 90 DEG TYPE C	2		
25-16	SP05---0802AD	LEVER, DOZER	1		
25-17	K1300000020	GRIP, RUBBER HANDLE 25.4	1		
25-18	K1604100000	JOINT, SPHERICAL LHSA10DE146	4		
25-19	K0072000300	SHAFT, SCREWED M10-80	2		
25-20	SP160EA0812Z2	SHAFT, CONNECTING	2		
25-21	K5051025370	WASHER, C5191P 1-25.4-37	2		
25-22	K6000000390	BUSH, COPPER 25.4-30.2-20	2		
25-23	SP05---0801AD	PIPE, DOZER LEVER FULCRUM	1		
25-24	K1440000010	GREASE NIPPLE, STRAIGHT TYPE A	1		
25-25	K0200060002	WASHER, SPRING M6	1		
25-26	K0320060361	PIN, SPRING M6-36	1		
25-27	SP05---0803ZD	ARM, LEVER	1		
25-28	SP05---0807ZD	PLATE, SUPPORTING ARM	1		
25-29	K4033000540	RUBBER, PLATE 3-2535	1		

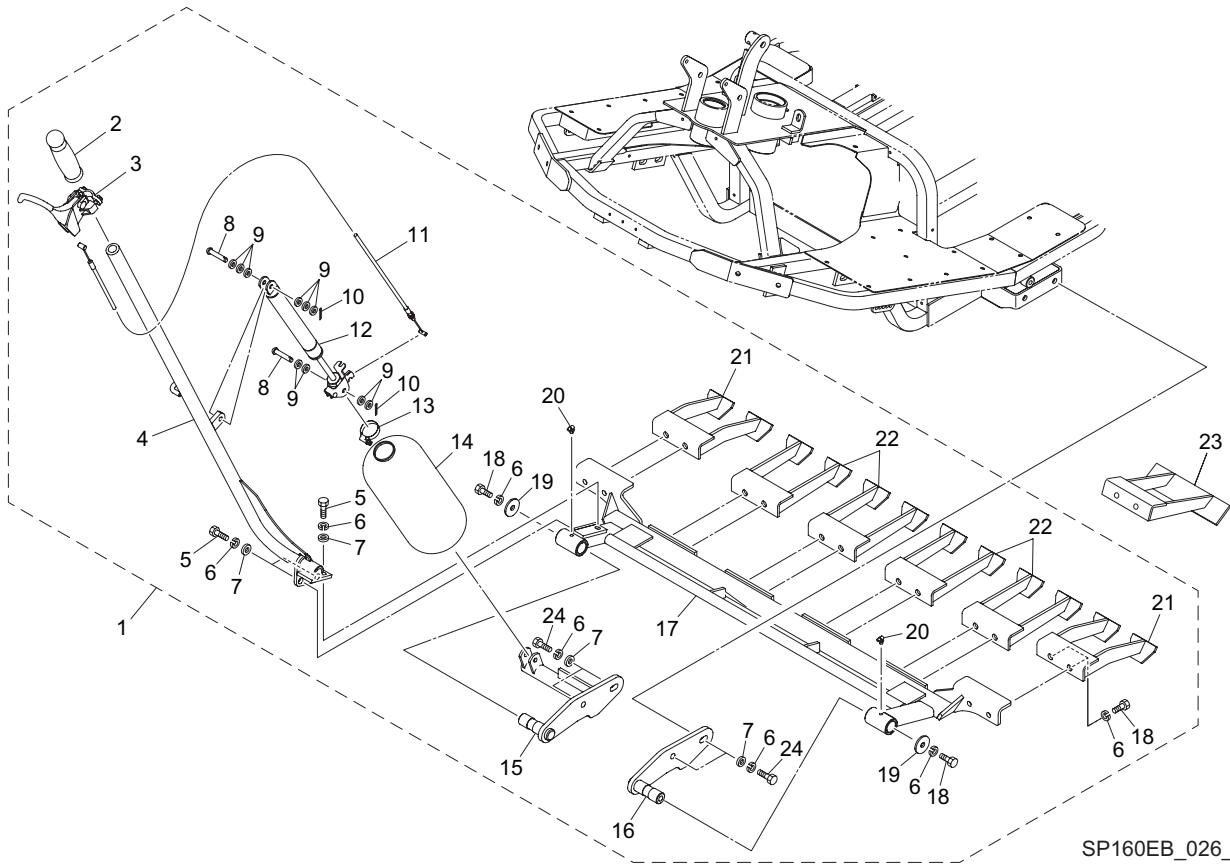

SP160EB_026_z02

Cat No.	Code No.	Part name	Qty	Remark	SN of application
26-1	SP05---0930B0	SAND CULTIVATOR ASSY	1	option	
26-2	K1300000020	GRIP, RUBBER HANDLE 25.4	1		
26-3	K1211460000	LEVER, CLUTCH E146000	1		
26-4	SP05---0933BD	LEVER, CULTIVATOR	1		
26-5	K0000100252	BOLT, M10-25	3		
26-6	K0200100002	WASHER, SPRING M10	21		
26-7	K5000100002	WASHER, M10	7		
26-8	K6041080428	PIN, ROUND HEAD HT M8-42	2		
26-9	K5000080002	WASHER, M8	10		
26-10	K0300025202	PIN, COTTER M2.5-20	2		
26-11	K1160082000	WIRE, ADJUSTING CULTIVATOR 820	1		
26-12	K3381000040	GAS-SPRING, FLF90-25	1		
26-13	K4260000190	CLAMP, HOSE JUBILEE BAND 1	1		
26-14	SP05---0912Z0	COVER, GAS SPRING	1		
26-15	SP05---0932BD	FULCRUM, (RH)	1		
26-16	SP05---0931AD	FULCRUM, (LH)	1		
26-17	SP05---0934ZD	ARM, CULTIVATOR	1		
26-18	K0000100202	BOLT, M10-20	14		
26-19	K5073210352	WASHER, SPHC 3.2-10-35	2		
26-20	K1440000020	GREASE NIPPLE, 90 DEG TYPE C	2		
26-21	SP05---0935ZD	TOOTH, TRAPEZOIDAL SIDE (CULTIVATOR)	2		
26-22	SP05---0909ZD	TOOTH, TRAPEZOIDAL (CULTIVATOR)	4		
26-23	SP05---0910ZD	TOOTH, FLAT (CULTIVATOR)	6	option	
26-24	K0000100302	BOLT, M10-30	4		

27. Finishing brush section

SP160EB

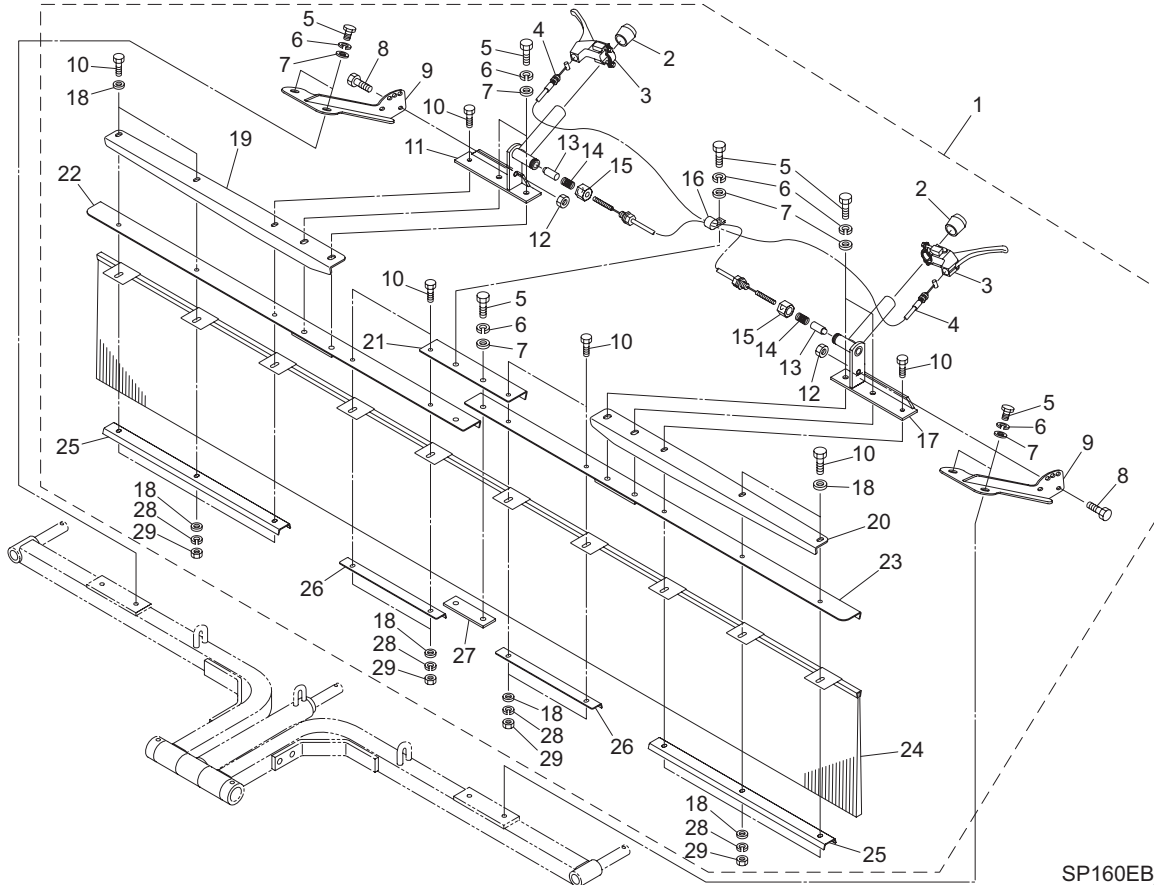

SP160EB_027_z00

Cat No.	Code No.	Part name	Qty	Remark	SN of application
27-1	SP05---1601A0	FINISHING BRUSH ASSY	1	option	
27-2	K1310000160	CAP, RUBBER 24	2		
27-3	K1211260150	LEVER, CLUTCH E126015	2		
27-4	K1160089000	WIRE, ADJUSTING 890	2		
27-5	K0000080252	BOLT, M8-25	10		
27-6	K5000080002	WASHER, M8	10		
27-7	K0200080002	WASHER, SPRING M8	10		
27-8	K0000100202	BOLT, M10-20	2		
27-9	SP05---1604ZD	ARM	2		
27-10	K0000060202	BOLT, M6-20	10		
27-11	SP05---1603ZD	ARM, MOVABLE (RH)	1		
27-12	K0100100002	NUT, M10	2		
27-13	BG90C--0710Z2	PIN, TAIL WHEEL UP/BTM FIXING PIN	2		
27-14	K1000000668	SPRING, COMPRESSION M1.4-11.3-40	2		
27-15	K6084000032	CAP, BODY	2		
27-16	K4270020080	CLIP, HARNESS 20 M8	1		
27-17	SP05---1602ZD	ARM, MOVABLE (LH)	1		
27-18	K5000060002	WASHER, M6	10		
27-19	SP05---1012ZD	PLATE, REINFORCING (RH)	1		
27-20	SP05---1011ZD	PLATE, REINFORCING (LH)	1		
27-21	SP05---1006ZD	PLATE, CONNECTING BRUSH FRAME	1		
27-22	SP05---1004AD	FRAME, BRUSH (RH)	1		
27-23	SP05---1005AD	FRAME, BRUSH (LH)	1		
27-24	SP05---1002Z0	BRUSH, FINISHING 1.0 (NY)	1		
27-25	SP05---1010ZD	PLATE, RETAINING BRUSH 450	2		
27-26	SP05---1008ZD	PLATE, RETAINING BRUSH 250	2		
27-27	K514200047D	PLATE, 6 W/ 2-M8 2570	1		
27-28	K0200060002	WASHER, SPRING M6	10		
27-29	K0100060002	NUT, M6	10		

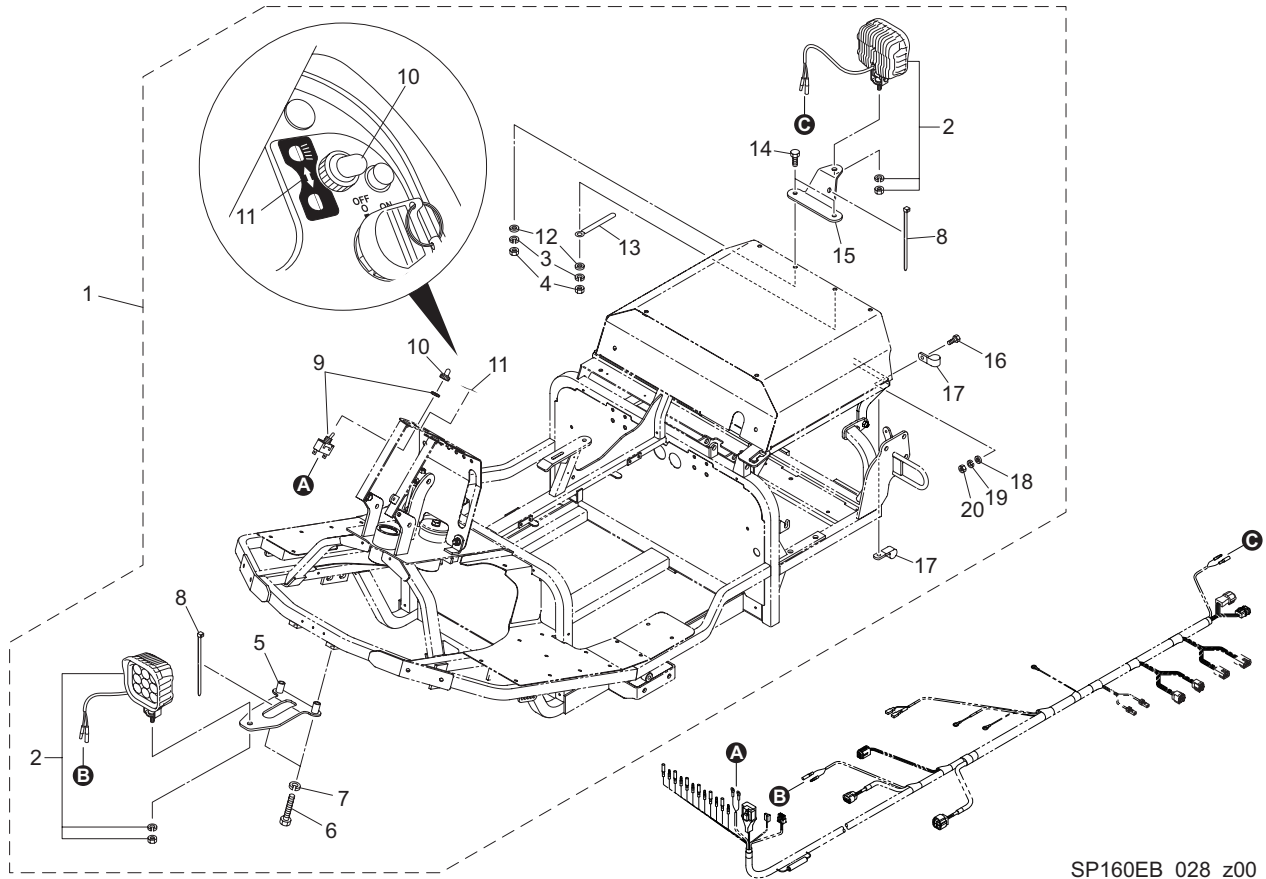

SP160EB_028_z00

Cat No.	Code No.	Part name	Qty	Remark	SN of application
28-1	SP160EB2001Z0	LIGHT PART ASSY	1	option	
28-2	K3640000080	LAMP, LED 22818	2		
28-3	K0200080002	WASHER, SPRING M8	2		
28-4	K0100080002	NUT, M8	2		
28-5	SP160EB2002ZD	BRACKET, LAMP (FRONT)	1		
28-6	K0000100602	BOLT, M10-60	2		
28-7	K0200100002	WASHER, SPRING M10	2		
28-8	K4241000040	BAND, PLASTIC TRCV-200W	2		
28-9	K3662000060	SWITCH, TOGGLE ST115AT	1		
28-10	K4031000300	RUBBER, CAP WD1911	1		
28-11	K4203001410	STICKER, LIGHT SWITCH	1		
28-12	K5000080002	WASHER, M8	2		
28-13	K4281000020	CLAMP, HARNESS 8.5 80	1		
28-14	K0000080202	BOLT, M8-20	2		
28-15	SP160EB2003ZD	BRACKET, LAMP (REAR)	1		
28-16	K0000060152	BOLT, M6-15	1		
28-17	K4270010060	CLIP, HARNESS 10-M6	2		
28-18	K5000060002	WASHER, M6	1		
28-19	K0200060002	WASHER, SPRING M6	1		
28-20	K0100060002	NUT, M6	1		

29. Cargo box section

SP160EB

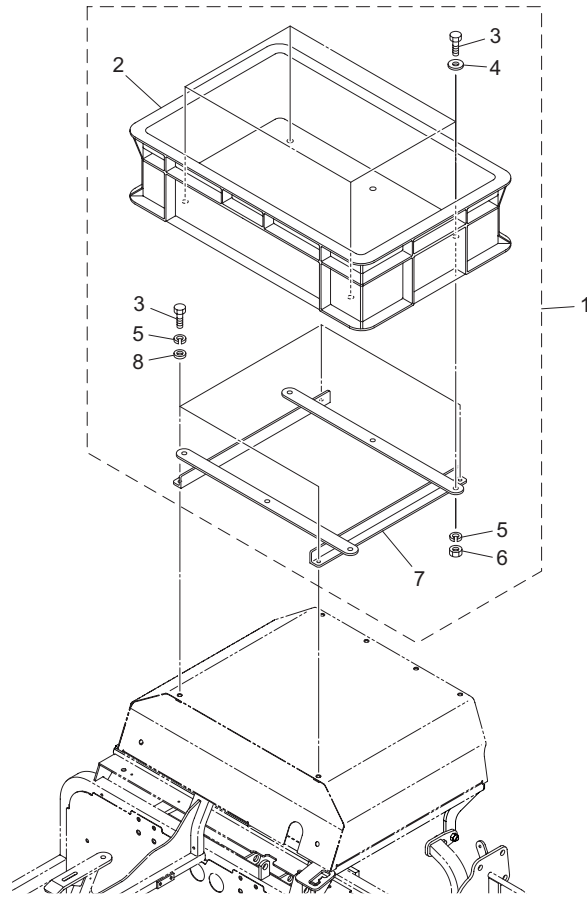

SP160EB_029_z00

Cat No.	Code No.	Part name	Qty	Remark	SN of application
29-1	SP160EB2101Z0	CARGO BOX KIT	1	option	
29-2	SP05---1304Z0	CARGO BOX	1		
29-3	K0000080202	BOLT, M8-20	8		
29-4	K5012308352	WASHER, SPCC 2.3-8-35	4		
29-5	K0200080002	WASHER, SPRING M8	8		
29-6	K0100080002	NUT, M8	4		
29-7	SP160EB2102ZD	BRACKET, CARGO BOX	1		
29-8	K5000080002	WASHER, M8	4		

30. Water refilling system (EB) section

SP160EB

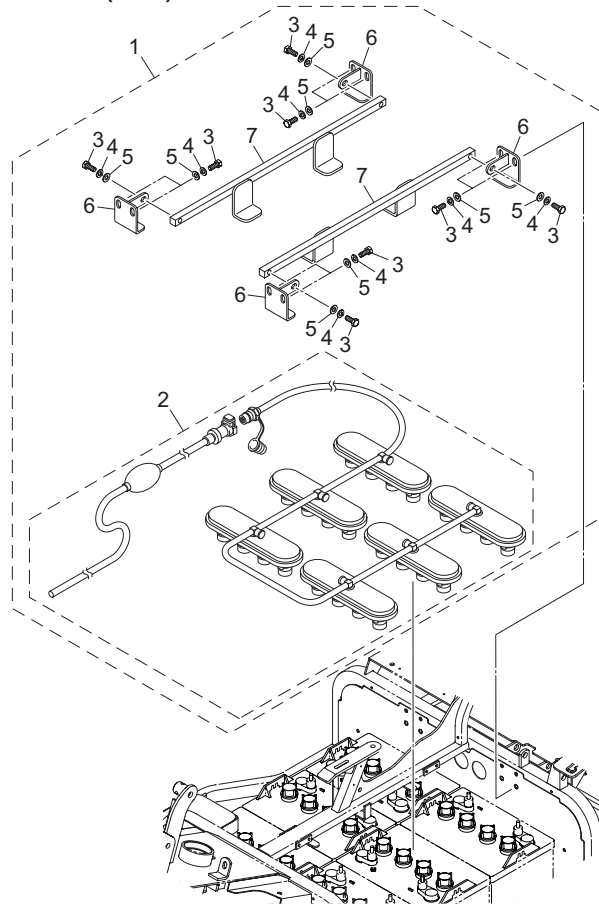

SP160EB_030_z00

Cat No.	Code No.	Part name	Qty	Remark	SN of application
30-1	SP160EB2207Z0	WATER REFILLING SYSTEM, (EB)	1	option	
30-2	SP160EB2202Z0	WATER REFILLING SYSTEM, (EB)	1		
30-3	K0000080202	BOLT, M8-20	12		
30-4	K0200080002	WASHER, SPRING M8	12		
30-5	K5000080002	WASHER, M8	12		
30-6	SP160EB2208ZD	BRACKET, WATER REFILLING SYSTEM	4		
30-7	SP160EB2209ZD	BRACKET, BATTERY (WATER REFILLING SYSTEM)	2		

BARONESS[®]
Quality on Demand

 **KYOEISHA CO., LTD.**
Head Office 1-26, Miyuki-cho, Toyokawa-city, Tel :+81-533-84-1390
Aichi-pref, 442-8530 JAPAN Fax :+81-533-84-1220